

PRIME DESIGN™

A Safe Fleet Brand

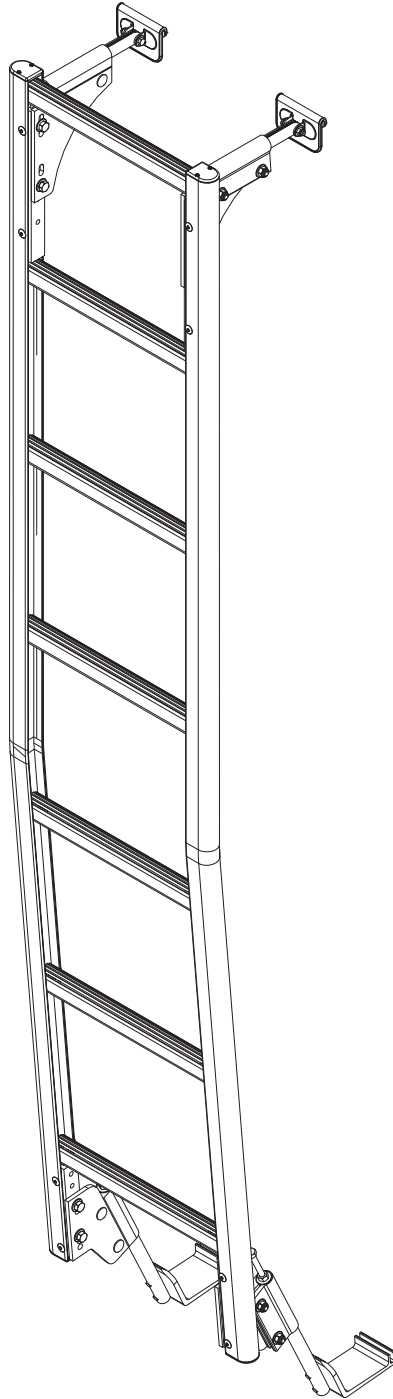

H3 2015+ FORD TRANSIT

PRIME DESIGN, A SAFE FLEET BRAND • Address: 1689 Oakdale Avenue #102, West St Paul, Minnesota 55118
Toll Free: 1.8.PRIME.RACK • Fax: 651-552-1799 • Email: info@primedesign.net • Website: www.primedesign.net

AAL-8011

CONTENTS OVERVIEW

1—Access Ladder (Qty 1)

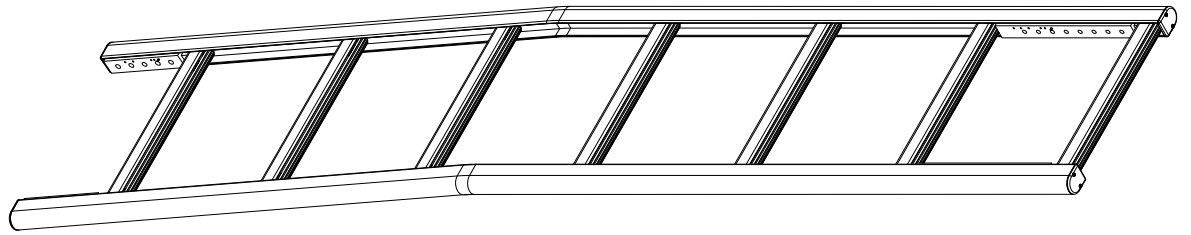

2—Mounting Bracket Assembly..... (Qty 1)
Access Ladder Upper, LH/RH Pair

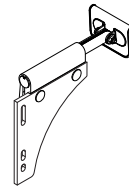

Left Hand (1X)

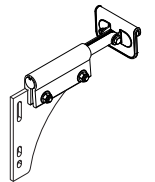

Right Hand (1X)

3—Hanger Brackets..... (Qty 1)
Ladder Bottom, LH/RH Pair



Left Hand (1X)



Right Hand (1X)

4—Mounting Bracket Assembly..... (Qty 1)
Access Ladder Lower, Pair

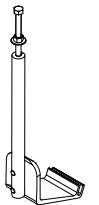

Non-Handed (2X)

5—HKT-0056 (Qty 1)
Access Ladder Hanger Bracket Hardware Kit

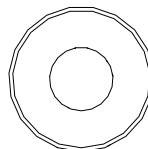

5/16" Flat Washer (8X)

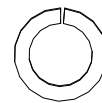

Lock Washer (8X)

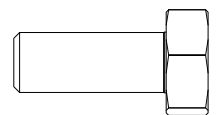

M8 x 20MM (8X)

INSTALLATION PROCEDURES



INSTALLER NOTE: It is important to correctly follow these assembly instructions. These instructions for assembly are provided by the manufacturer at time of Access Ladder delivery, and reflect the technical specifications applicable at the time of writing.

- These instructions are subject to change if the manufacturer revises the parts and/or production of the subsystems and accessories used in the brand's vehicles. Following the instructions for assembly will ensure proper installation of the product. The manufacturer will not be held liable if these instructions are not followed.
- This Access Ladder is designed to be installed in one specific position on the vehicle. Attachment to the vehicle may be compromised if the position is different from that shown in these instructions.
- Do not add or place any additional material (rubber, plastic, etc) between the Door Brackets and the vehicle's body unless supplied with your Access Ladder. The use of additional nonessential material may prevent proper holding of the Access Ladder to the vehicle's door, leading to vehicle body and/or Ladder damage.
- The vehicle's door must be securely closed and latched at the top and bottom prior to using this Access Ladder. Failure to do so may cause damage to the vehicle's door & hinges, and/or cause personal injuries.
- The addition of parts and/or components not original to this Ladder Assembly are discouraged. Use only OEM supplied parts.
- It is essential to check and retorque the mounting fasteners after the first week of initial service, then monthly thereafter.

- Do not use power tools to tighten fasteners as power tools may lead to overtightening and cause damage to the vehicle, or the Ladder hardware. Use only hand tools as shown below.

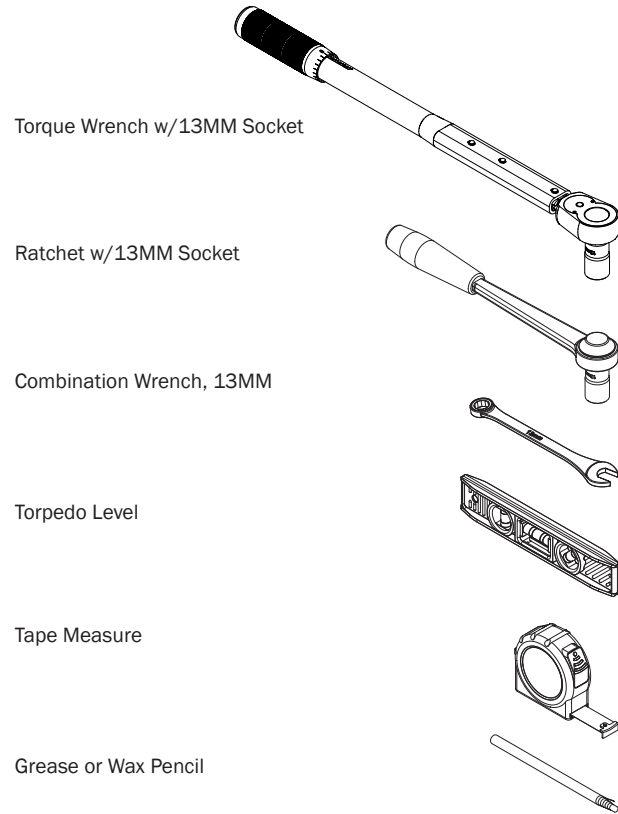

ACCESS LADDER ASSEMBLY SEQUENCE

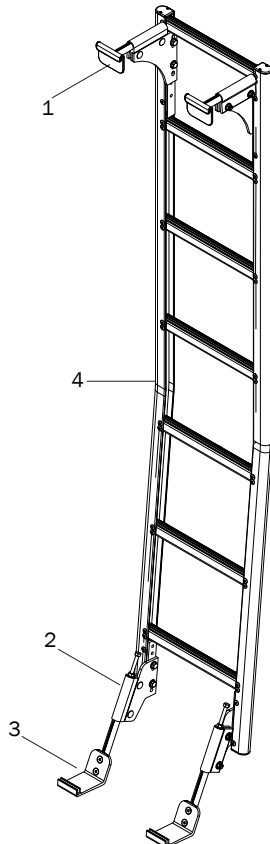

UPPER MOUNTING BRACKETS

- 1.1** Assemble the left side Upper Bracket to the Ladder using the indicated hardware. The bolts must screw into bolt holes #1, and #4 of the Hanger Connector.

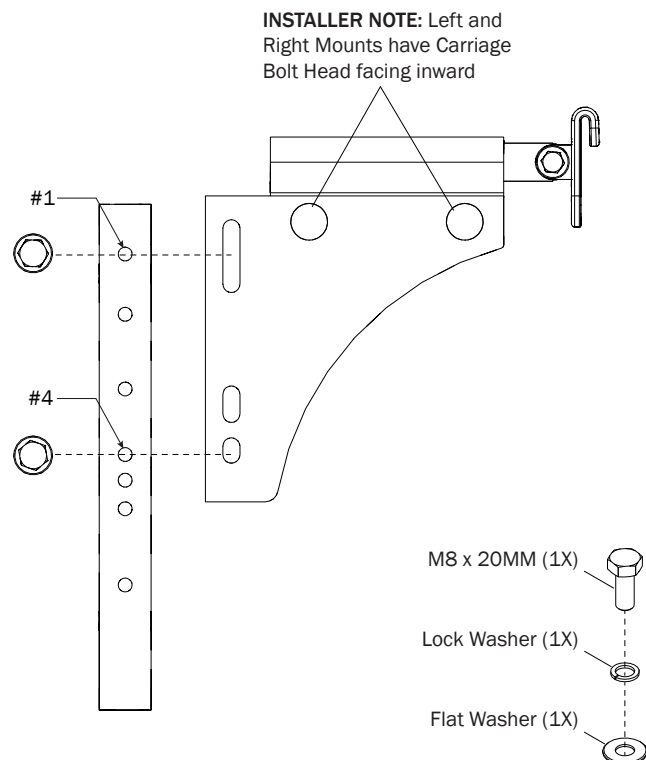

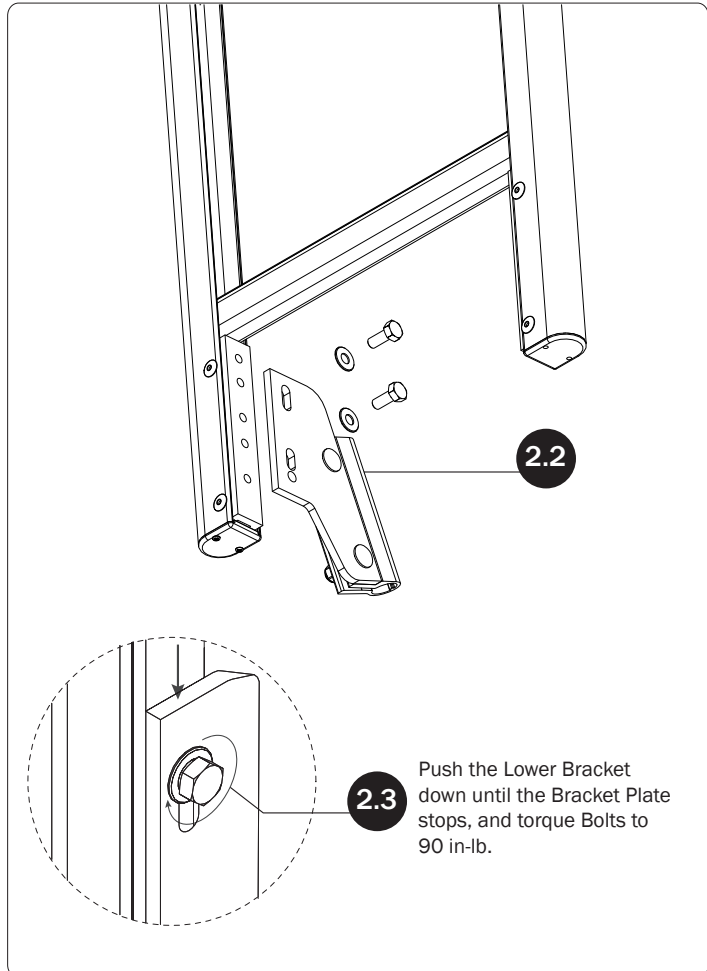
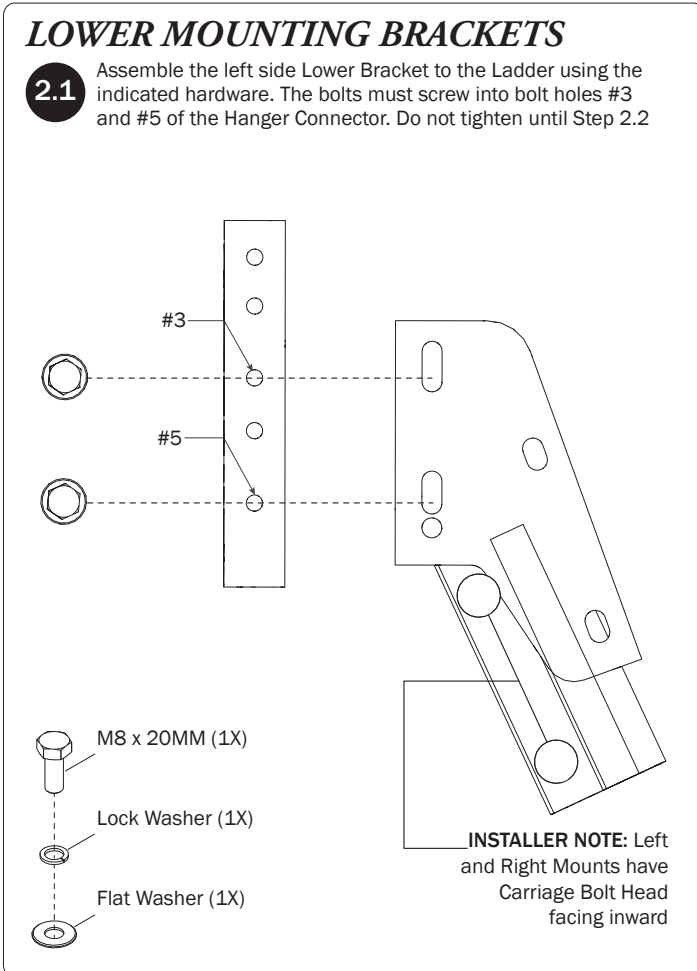
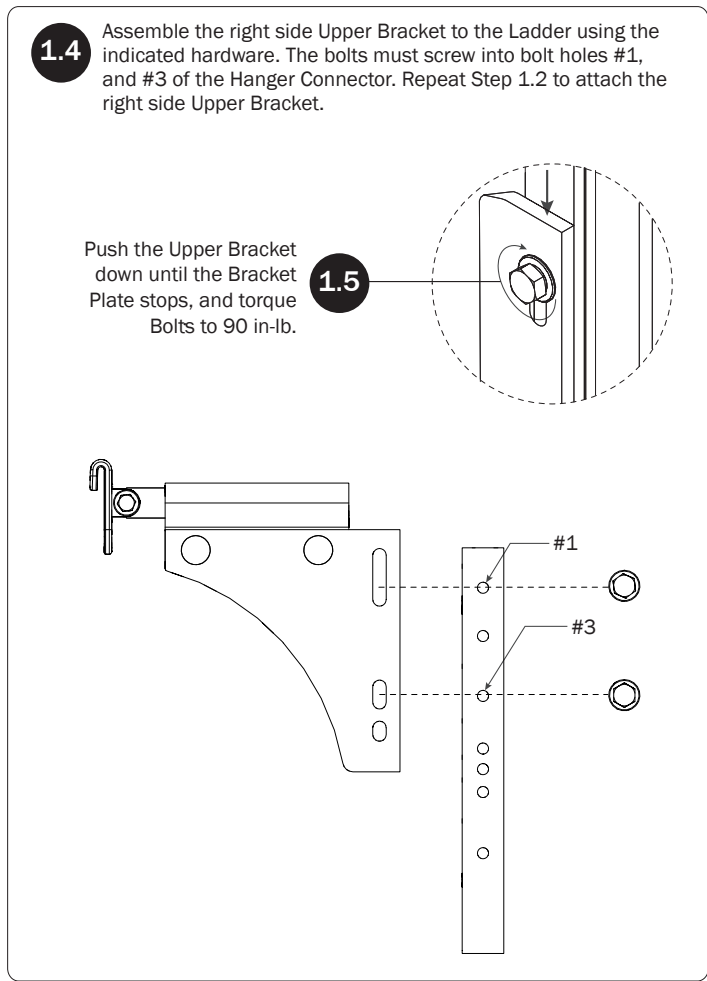
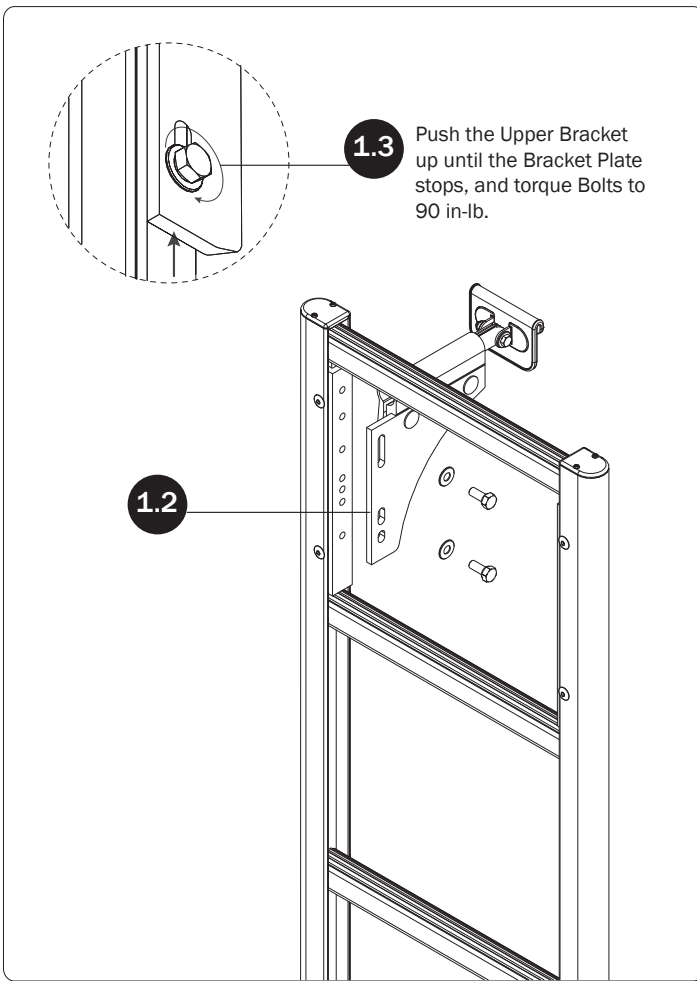

LOWER MOUNTING HANGER RODS

2.4 Assemble the right side Lower Bracket to the Ladder using the indicated hardware. The bolts must screw into bolt holes #3, and #5 of the Hanger Connector. Repeat Step 2.2 to attach the right side Lower Bracket.

Push the Lower Bracket down until the Bracket Plate stops, and torque Bolts to 90 in-lb.

2.5

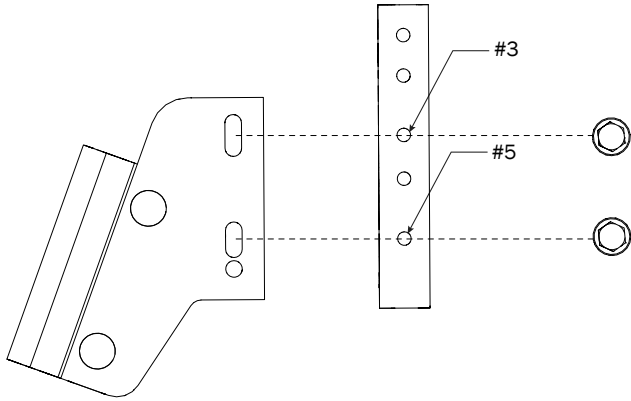
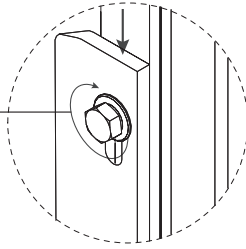

3.1

This Lower Mounting Hanger Rod comes from the factory pre-assembled.

It is necessary to remove the tightening hardware for installation into the Hanger Rod Clamps as seen in Step 3.2

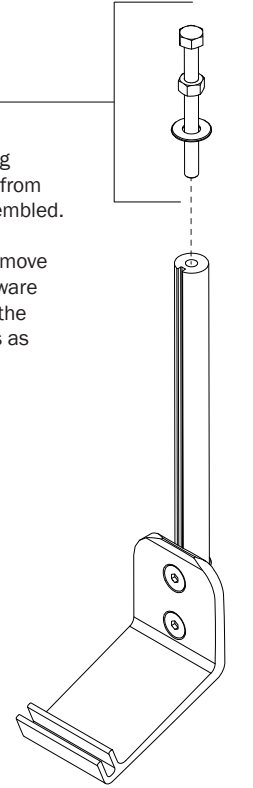

3.3

Reinstall Hanger Rod hardware removed during Step 3.1

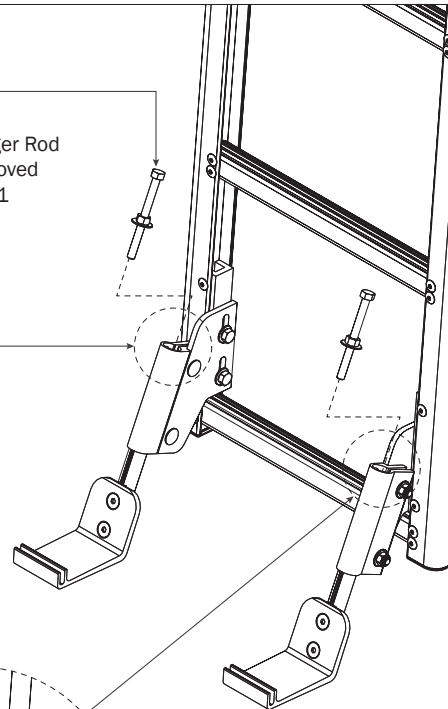

3.4

Do not tighten until Steps 4.5-4.8

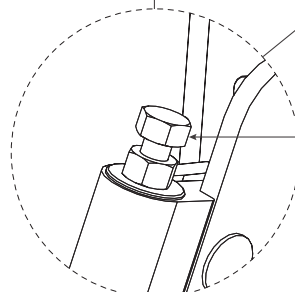

3.2

Slide the Lower Mounting Bracket Hanger Rods into the Hanger Rod Clamps.

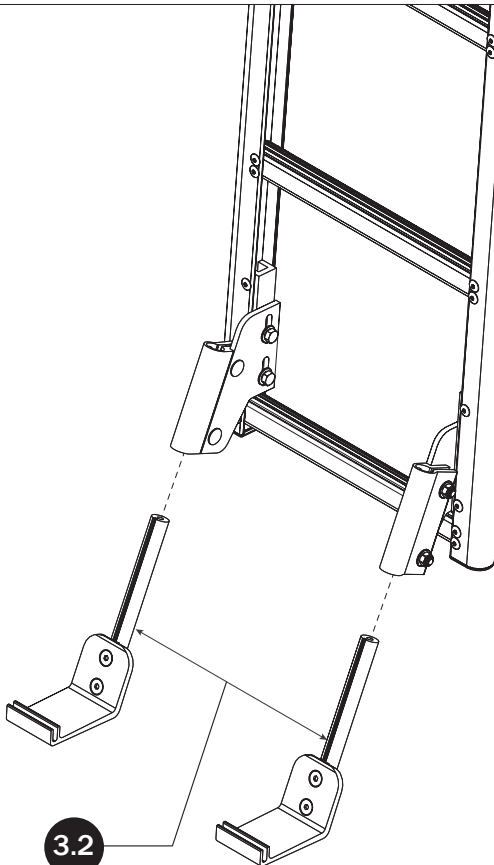

ACCESS LADDER INSTALLATION

INSTALLER NOTE: For an accurate installation, it is recommended the vehicle that is receiving this ladder be sitting on as level of ground as possible.

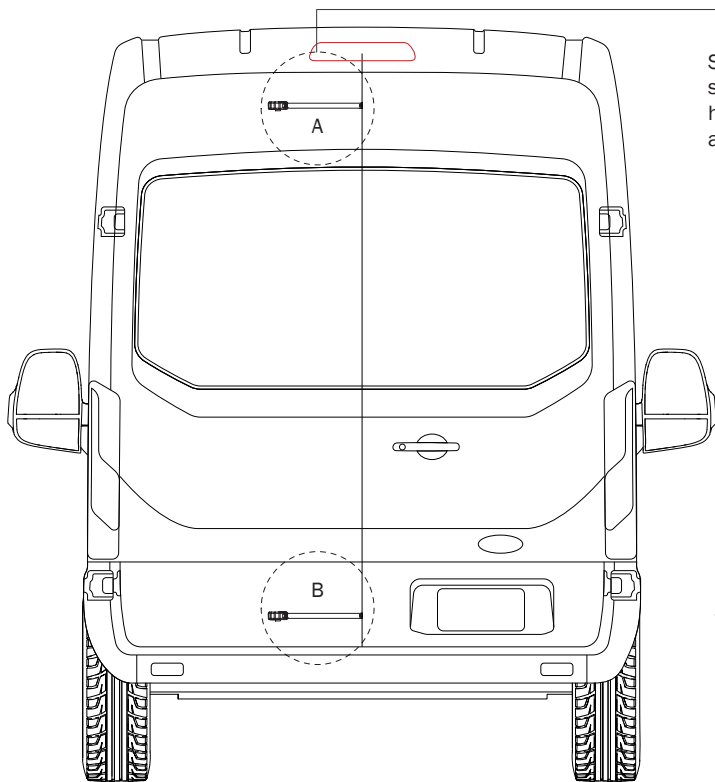

4.1

Starting at the inner door seam (A and B), measure horizontally outward approximately 4.00"

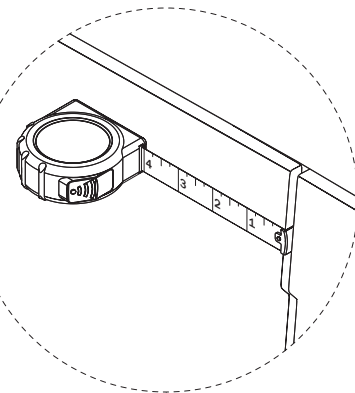

4.2

Using a wax or grease pencil, make marks at the top (A) and bottom (B) of the door at 3-1/8"

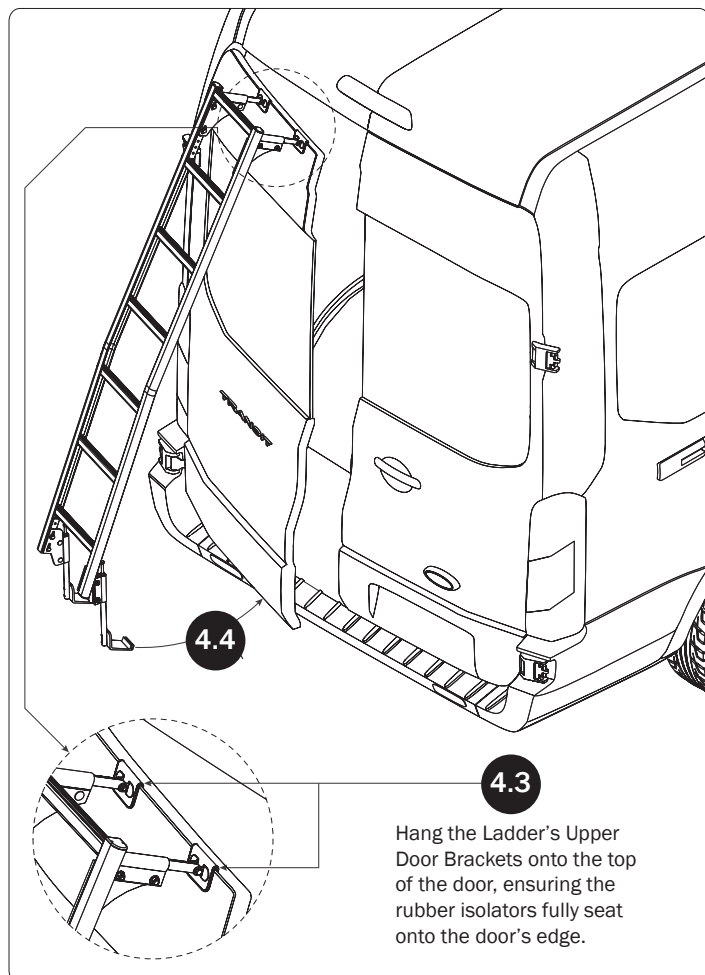
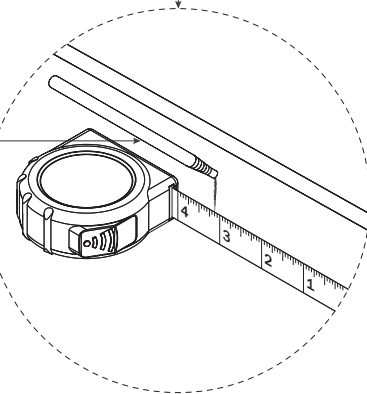

4.3

Hang the Ladder's Upper Door Brackets onto the top of the door, ensuring the rubber isolators fully seat onto the door's edge.

4.4

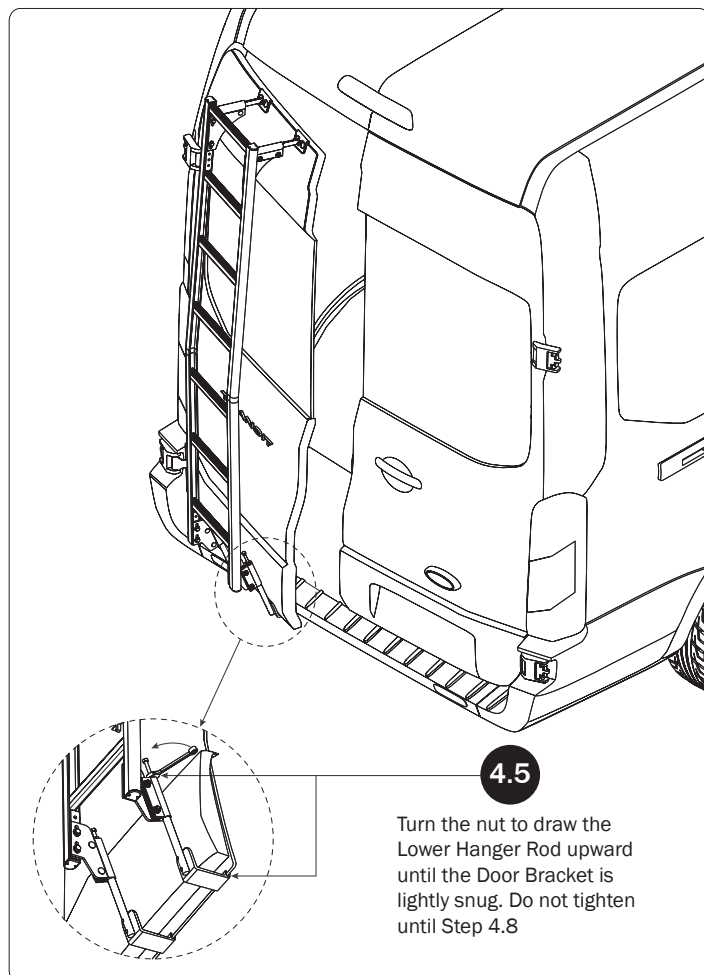

4.5

Turn the nut to draw the Lower Hanger Rod upward until the Door Bracket is lightly snug. Do not tighten until Step 4.8



INSTALLER NOTE: Overtightening the Hanger Rod nuts may cause the Door Brackets to damage the door skin.

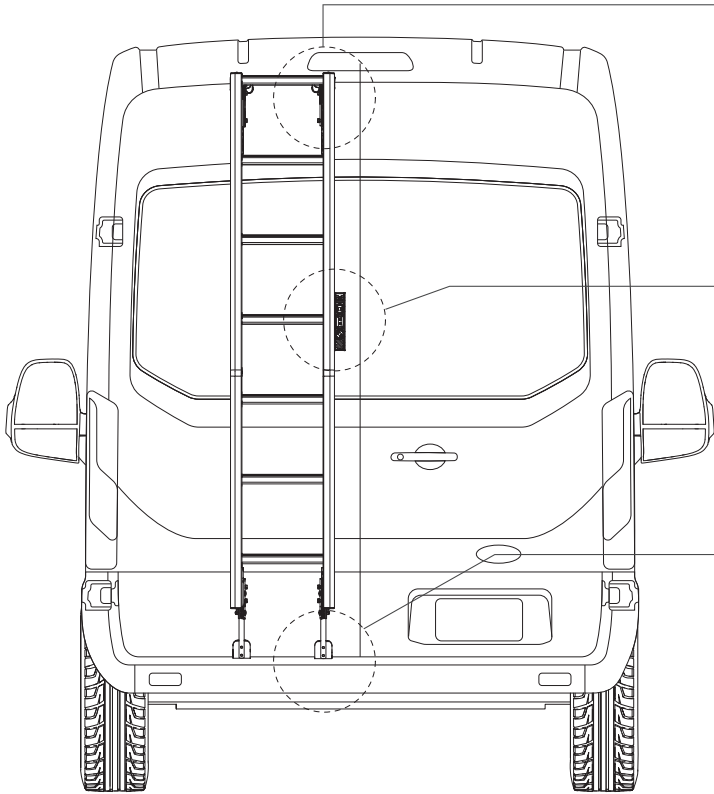

4.6

Align the upper left Door Bracket edge to the pencil mark made during Step 4.1
Tighten Door Bracket bolt until the Bracket is snug.

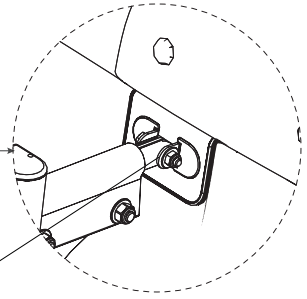

4.7

Adjust the bottom of the Ladder until the bubble is centered in the level. Further verify correct vertical positioning by visually inspecting the bottom pencil mark made during Step 4.2

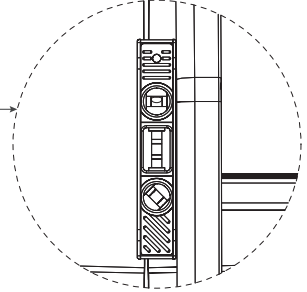

4.8

Tighten the Lower Hanger Rod nut until the Door Bracket's rubber isolator begins to compress
Tighten Door Bracket bolt until the Bracket is snug.

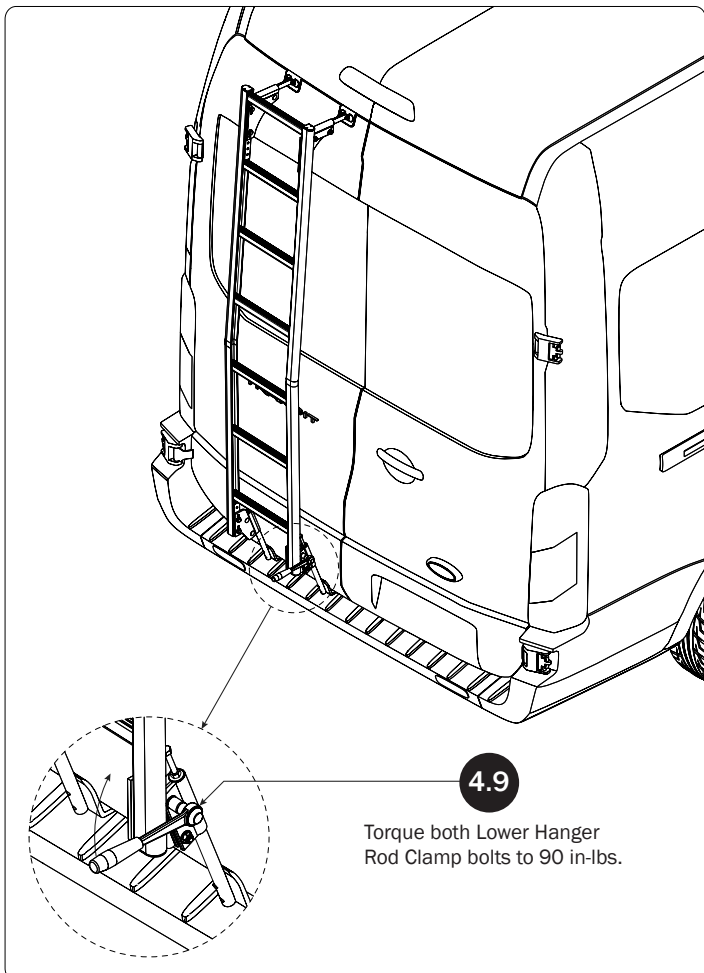
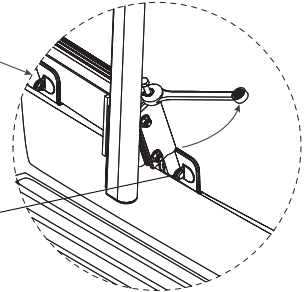

4.9

Torque both Lower Hanger Rod Clamp bolts to 90 in-lbs.

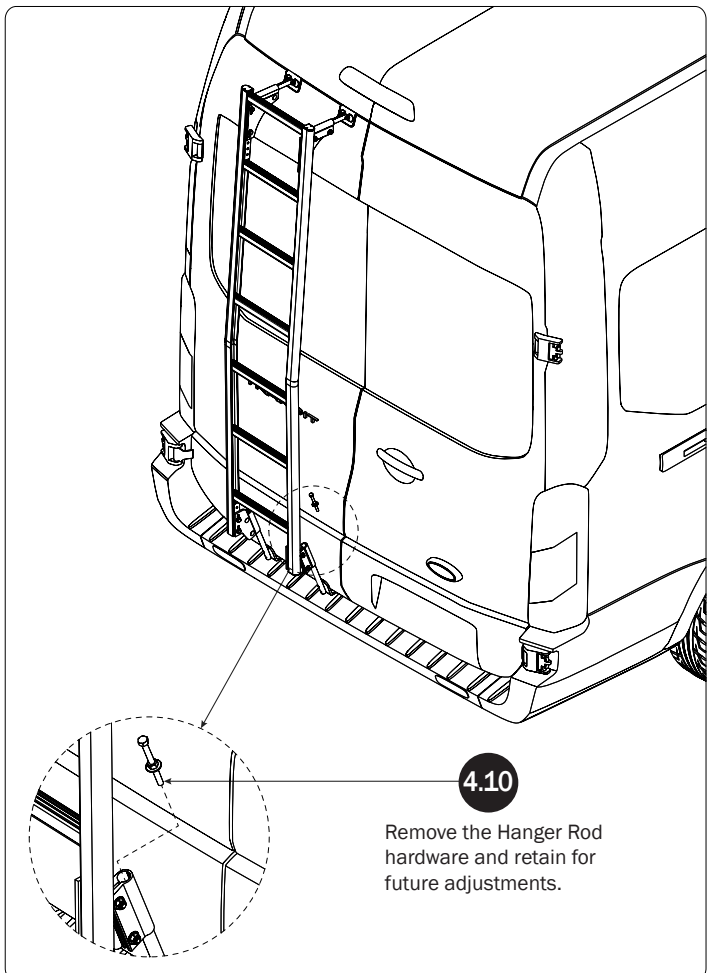
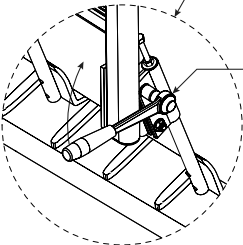

4.10

Remove the Hanger Rod hardware and retain for future adjustments.

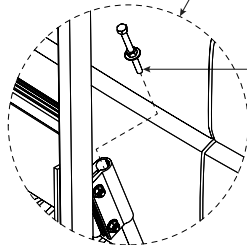

USE AND MAINTENANCE



END USER NOTE: *The following Use and Maintenance guidelines found in this section do not cover every proper and improper procedure for the use and maintenance of this Access Ladder, but do reflect the accepted best practices applicable at the time of writing.*

Use:

- When ascending or descending the Access Ladder, the User must face the ladder and maintain a three-point contact at all times. Three-point contact consists of: two feet and one hand, or one foot and two hands to safely support the User's weight when ascending or descending the Access Ladder.
- The User must not carry tools or equipment in hand while ascending or descending the Access Ladder. Both hands and arms must remain free for climbing. Hand tools must be carried in a pouch holster, tool belt, or otherwise secured to avoid creating a safety hazard. Safe alternative methods of handling materials and supplies must be implemented by the Access Ladder User.
- The User must never jump from, or slide down, an Access Ladder more than one rung or step at one time.
- To prevent a loss of grip hazard, Users must avoid ascending or descending the Access Ladder with greasy or slippery hands, or gloves.
- Keep the Access Ladder free of oil, grease, or slippery substances that may cause a loss of grip hazard. Footwear must also be kept clean and free of similar substances.
- The User must avoid ascending or descending the Access Ladder during high winds or storms. If ice, frost, or snow is present on the ladder, it must be cleared prior to use.
- Users who tire easily, have physical limitations such as fainting, or during the use of medication or prescription drugs that may cause physical impairment, or any other condition that may prevent safely climbing the Access Ladder, must not be permitted to use the Access Ladder.
- Do not drive the vehicle when the vehicle's rear door is open, or the Access Ladder is in use by persons.

Maintenance:

- The Access Ladder must be maintained in a safe working condition. Inspection for corrosion and deterioration must be performed every six (6) months, or more frequently as determined by environmental exposure and conditions. Access Ladder inspections must include the following major components: Rungs, side rails, mounting brackets, mounting fasteners, rubber isolators, and rivets.
- Check the fitment of the Access Ladder to the vehicle's rear door ensuring it retains the correct positioning as outlined in Steps 4.6 & 4.7. Readjust the Access Ladder if it is out of specification.
- All mountings, fasteners, and hardware must be intact and secure for Access Ladder use. If any of these items are missing, loose, or damaged, the Access Ladder must be removed from service until such conditions have been corrected, and the Access Ladder is back in its original usable condition.
- All new, fixed, or repaired Access Ladders and its components must have all OEM safety stickers, labels, decals, markings, and/or information located in a conspicuous place on the Access Ladder. Missing Access Ladder safety labels must be replaced with only OEM approved labels. Contact a Prime Design Sales & Service Representative to obtain OEM approved labels.
- When structural damage or defects makes an Access Ladder hazardous, the Access Ladder must be taken out of service and either repaired by a competent individual, or removed and/or destroyed so it cannot be used.

Maintenance Cont'd:

- When repairs are effected to an Access Ladder, the materials must be direct OEM replacements.
- The Access Ladder is manufactured of aluminum, and is finished in a Bright Dip Anodize process to protect against corrosion, scratching, and fading on aluminum parts and products. Anodized aluminum may be subjected to tars, road film, mud, snow, ice and salt, which create a corrosive environment. Prolonged, continuous exposure to these elements without cleaning can cause some local breakdown of the anodizing layer. Harsh chemical cleaners are not to be used for maintaining anodized aluminum, while aggressive alkaline or acid cleaners must never be used. Mild soap and water will remove most soils from the Access Ladder. Stubborn contaminants are readily removed with commercially available automotive aluminum cleaners and polishes. Excessive abrasive rubbing must not be used since it might damage the finish.
- Strong cleaners must not be used on window glass and other surrounding non-ladder components where it is possible for the cleaner to come in contact with the aluminum. If contact does occur, immediately wash the ladder to reduce the possibility of damaging the Access Ladder's finish.
- Records must be maintained of annual or regularly scheduled inspections, maintenance, and repairs.

USAM-AAL8011-US01 Rev-D 0719