

INSTALLATION GUIDE

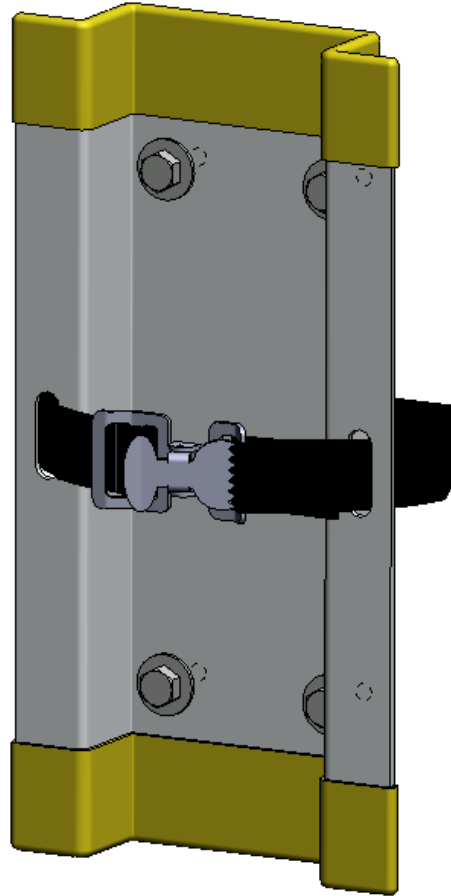

6086 Bottle Holder

Small (Aluminum)

REQUIRED ITEMS



1
PERSONS

- Cordless Drill
- Cordless Impact
- 3/8" Drill Bit
- 1/2" Socket
- Marker
- Knife

PHASE 1 – ASSEMBLY

1.1 SETUP

1.1.1 Unpack the paper holder and the Installation fastener bag.

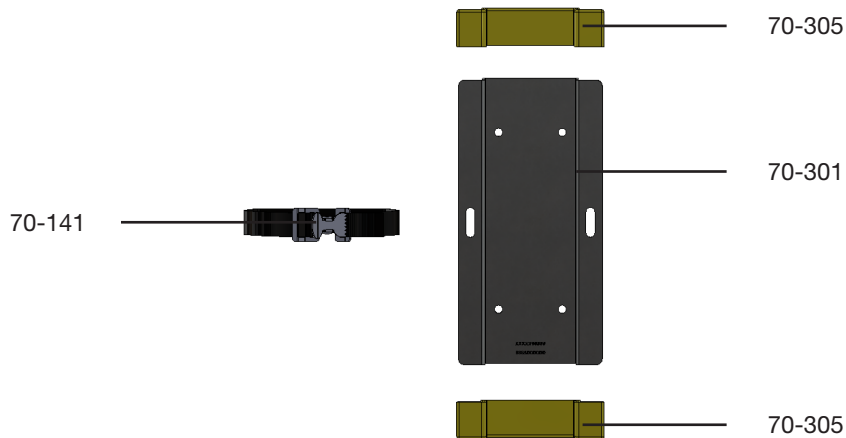

1.1.2 Verify all parts are present.





Item No.	Description	Qty.
70-141	Black Nylon Strap	1
70-301	Small Bottle Holder	1
70-305	Plastic Cap	2
96-1025	Customer Installation Fastener Kit	1

1.1.3 Fastener kits.





96-#### Fastener Kit



Fastener Assembly

4x		# 90-208	Hex Bolt 5/16"-18 x 1" GR-5 ZINC
4x		# 94-116	Serrated Nut 5/16"-18 ZINC
4x		# 98-116	Flat Washer 5/16" x 18 ZINC
4x		# 98-157	Spacer 0.375" ID, x 1.0" OD x 0.25" LONG NYLON

16x

	#90-208 Hex Bolt	5/16" x 1"
	#98-116 Flat Washer	
	#98-157 Spacers	
	#94-116 Serrated Nut	

PHASE 1 – ASSEMBLY

1.2 BOTTLE HOLDER ASSEMBLY

- 1.2.1
- Remove all the PVC from all the parts.
 - Attach the plastic cap on the ends of the small bottle holder.
 - Attach the black strap on the small bottle holder.

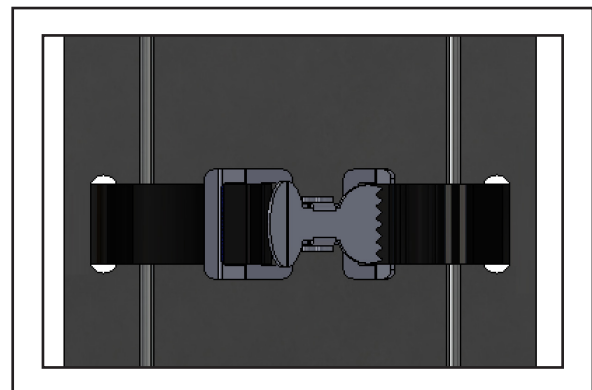
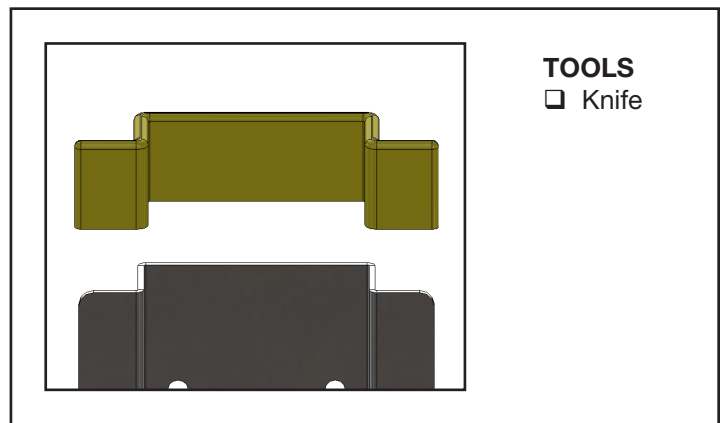
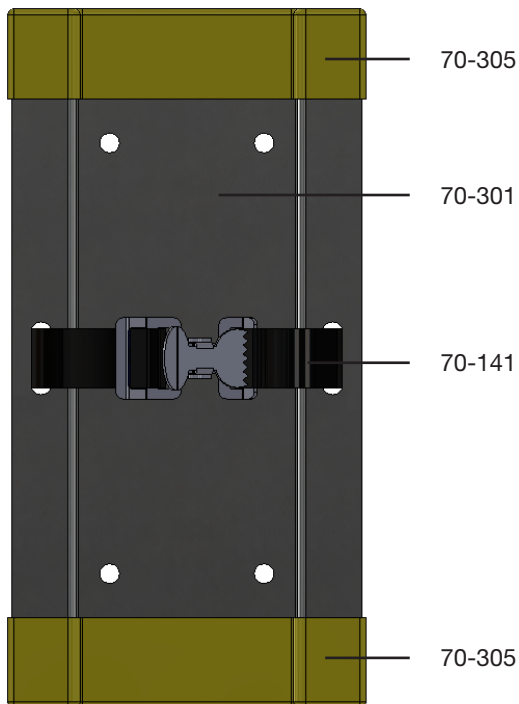

PHASE 2 – INSTALLATION

2.1 BOTTLE HOLDER INSTALLATION

- 2.1.1 • Sample vehicle package picture with 6107 bottle holder.
- Mark the 4 holes on the bottle holder, then drill the mark using 3/8" drill bit.

NOTE: The position of the bottle holder is depends on your package.

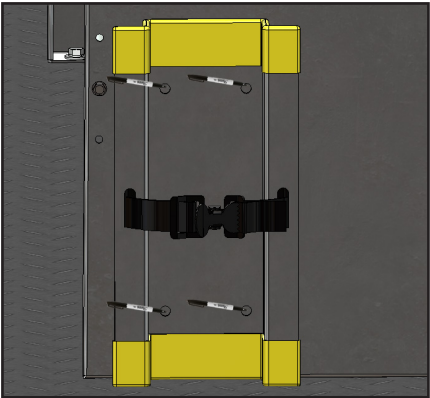
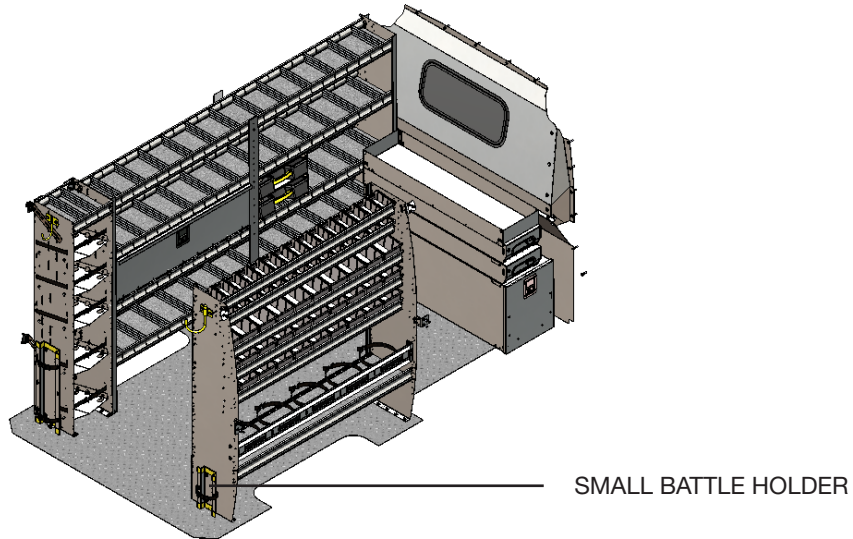

TOOLS

- Marker

Mark the 4 holes of the bottle holder to the end panel or flat surface.

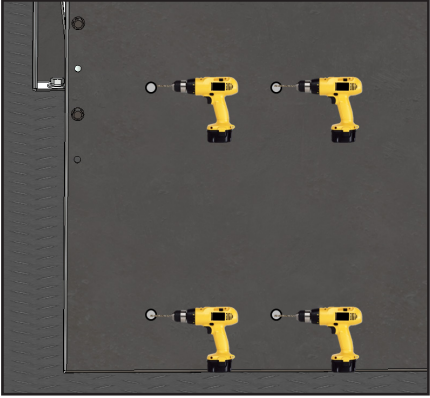

Drill all the marks using 3/8" drill bit.

NOTE: Ensure that there is nothing obstructing the other side of the holes e.g. shelves.

TOOLS

- Cordless Drill
- 3/8" Drill Bit

2.1.2 Install the bottle holder.

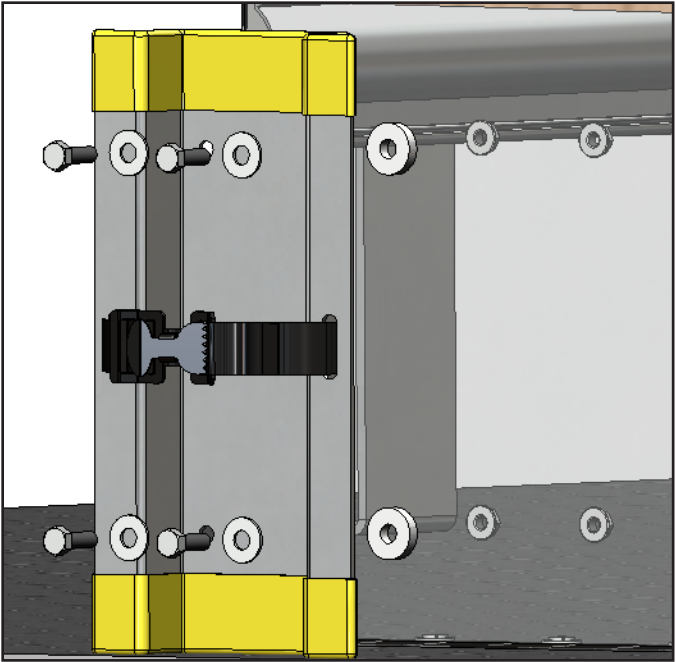
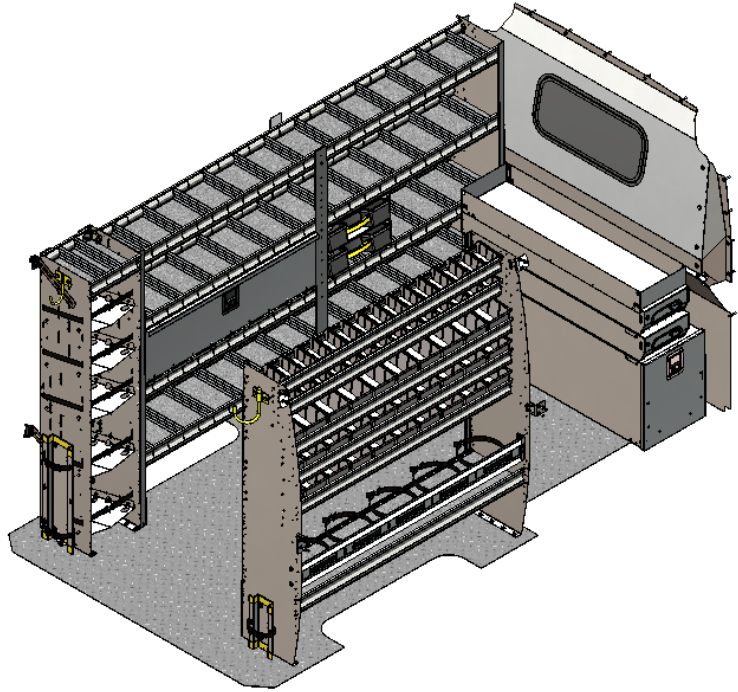





NOTE: Put the spacers on the back of the bottle holder.

TOOLS

- Cordless Impact
- 1/2" Socket

HARDWARE USED

4x

	#90-208 Hex Bolt 5/16" x 1"
	#98-116 Flat Washer
	#98-157 Spacers
	#94-116 Serrated Nut

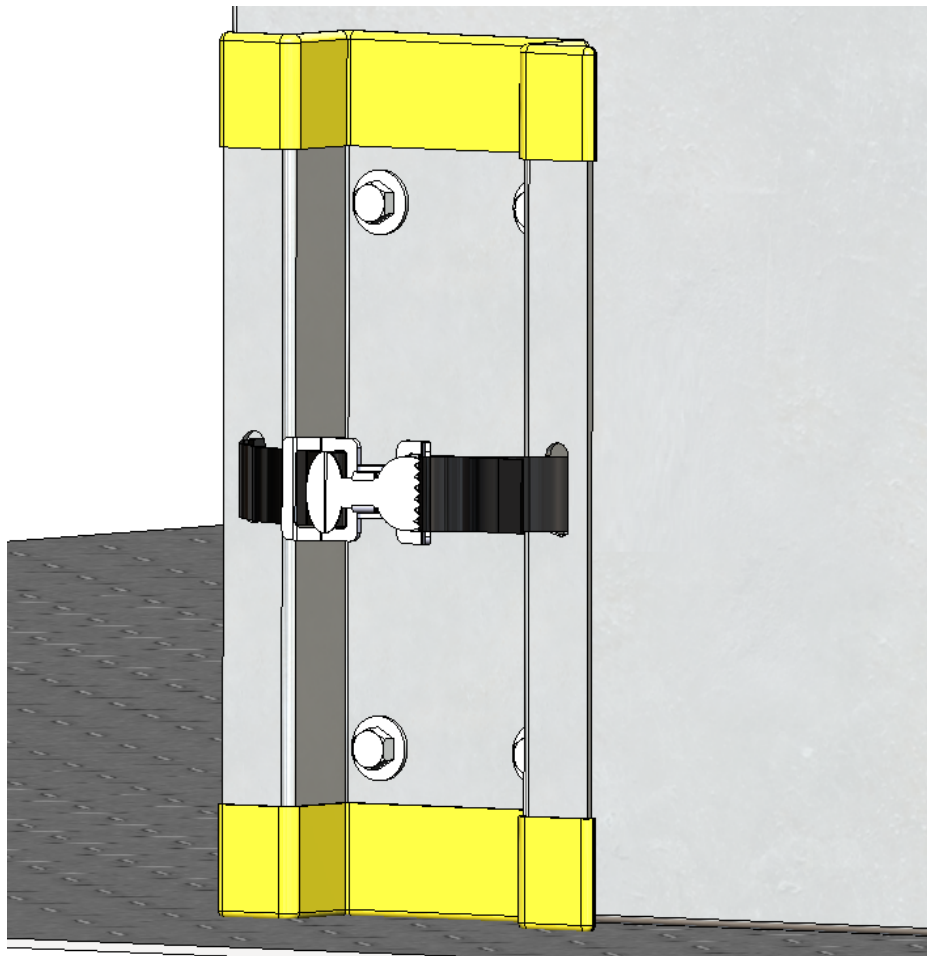

**“You have successfully installed your
6086 Small Bottle Holder**

Thank you for doing business with us.”

For any feedback or suggestions you may have, please contact: cs@rangerdesign.com

