

# INSTALLATION GUIDE

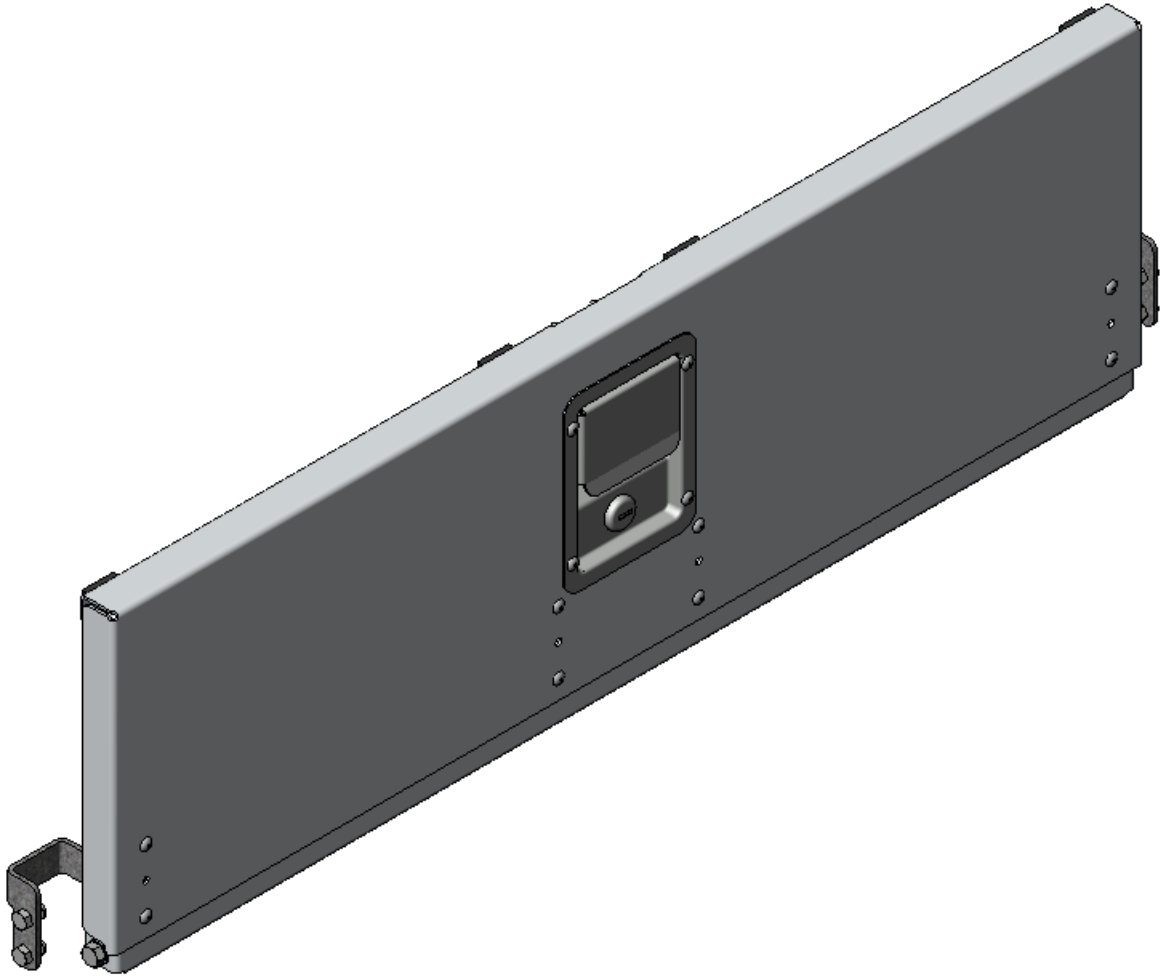

**77-U1036 Shelving Door**  
( ALUMINUM )

# QUICK START GUIDE

## Phase 1 - Assembly

- 1.1 Setup..... 3 - 4
- 1.2 Door Assembly..... 5 - 6

## Phase 2 - Installation

- 2.1 Door Installation..... 7 - 9
- 2.2 Striker Plate Install..... 10

# REQUIRED ITEMS

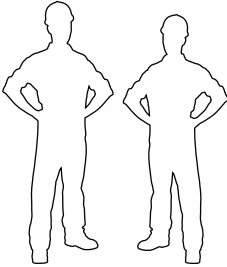

**2**  
**PERSONS**

- Ratchet
- Rivet Gun
- Tape Measure
- Marker
- 1/2" Socket
- 7/16" Socket
- 7/16" Wrench
- 1/2" Wrench
- Knife

# PHASE 1 – ASSEMBLY

## 1.1 SETUP

1.1.1 Unpack components; compare with the bill of materials.

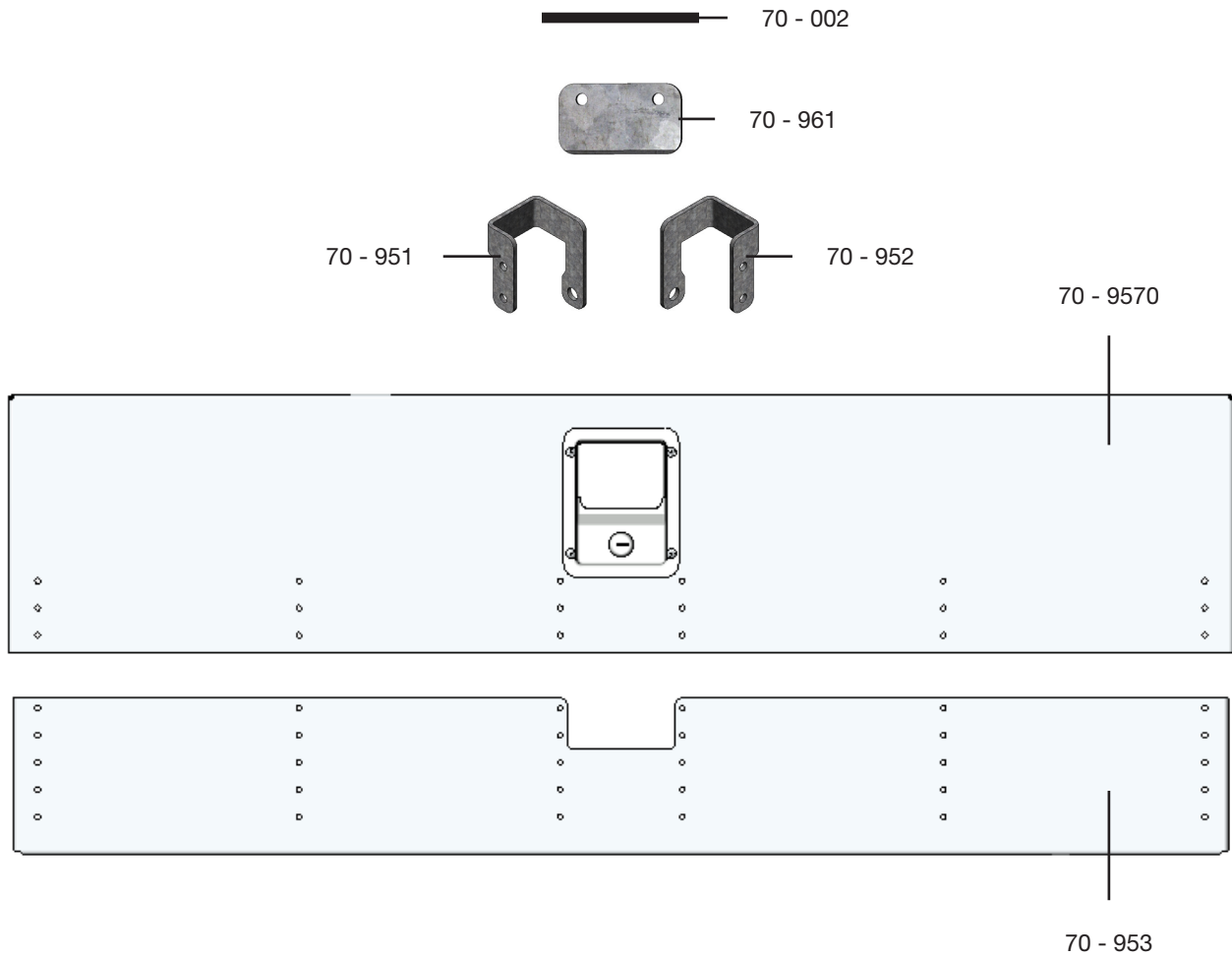

1.1.2 Verify all parts are present.

### BILL OF MATERIALS

Item No.	Description	Qty.
70-002	Foam Tape ( QTY in Inches )	4
70 - 951	Door Bracket ( Left )	1
70 - 952	Door Bracket ( Right )	1
70 - 953	Lower Door Panel	1
70 - 961	Striker Plate	1
70 - 9570	Upper Panel w/ Latch ( 36" )	1
94 - 4030	Assembly Fastener Kit	1
96 - 4029	Install Fastener Kit	1

1.1.3 Fastener kits.



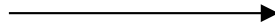

94 - 4030 Fastener Kit



Fastener Assembly

- 2x  # 90-206 Hex Bolt  
5/16"-18 x 7/8"  
GR-5 ZINC
- 2x  # 94-110 Lock Nut  
5/16"  
ZINC
- 8x  # 96-202 Closed End Blind Rivet  
3/16" Type #64
- 2x  # 98-134 Shoulder Washer  
5/16"  
NYLON
- 4x  # 98-116 Flat Washer  
5/16"  
ZINC

2x

 #90-206 Hex Bolt 5/16" x 7/8"  
 #98-134 Shoulder Washer  
 #98-116 Flat Washer  
 #98-116 Flat Washer  
 #94-110 Lock Nut



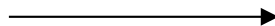

8x

 #96-202 Closed End Blind Rivet



96 - 4029 Fastener Kit



Fastener Assembly

- 1x  # 90-212 Hex Bolt  
5/16"-18 x 1 - 1/4"  
GR-5 ZINC
- 4x  # 90-106 Hex Bolt  
1/4"-20 x 1/2"  
GR-5 ZINC
- 4x  # 94-106 Lock Nut  
1/4"  
ZINC
- 2x  # 92-200 Screw HFH  
#10 - 16 x 3/4"  
ZINC
- 1x  # 98-143 Spacer  
.38" ID x .875" OD x .375" L  
Nylon

4x

 #90-106 Hex Bolt 1/4" x 1/4"  
 #94-106 Lock Nut

2x

 #92-200 Screw #10 - 16 x 3/4"

# PHASE 1 – ASSEMBLY

## 1.2 DOOR ASSEMBLY

1.2.1 Attach the lower door panel to the upper door panel.

**NOTE:** The height of the door depends on the height between the two shelf trays.

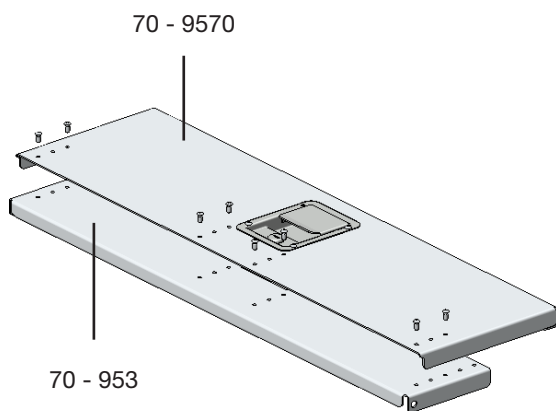

10 - 5/16" Door is for 13" height between two shelf trays or 9 holes.

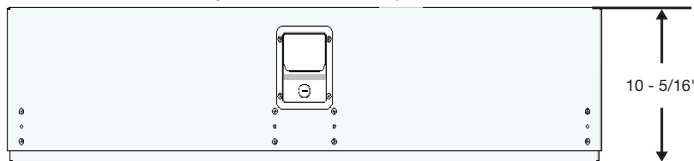

11 - 5/16" Door is for 14" height between two shelf trays or 10 holes.

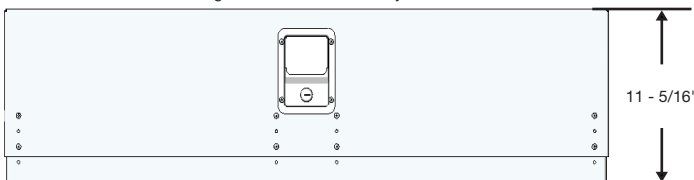

12 - 5/16" Door is for 15" height between two shelf trays or 11 holes.

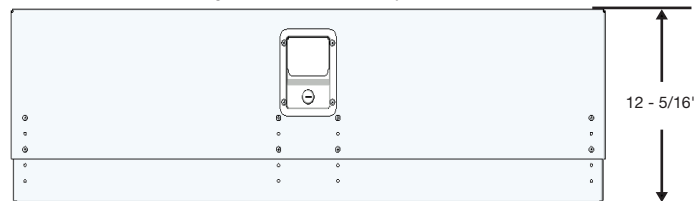

13 - 5/16" Door is for 16" height between two shelf trays or 12 holes.

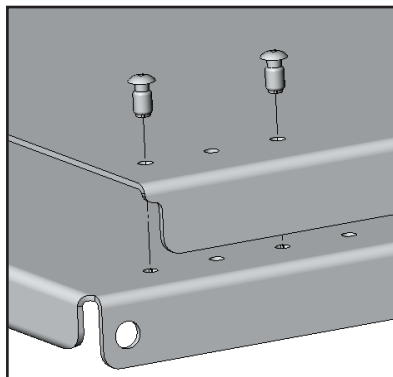
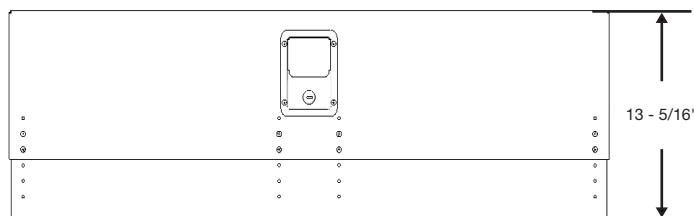

### TOOLS

- Rivet Gun

### HARDWARE USED

8x



#96-202 Closed End Blind Rivet

1.2.2 Cut the foam tape into 4 pieces of 1", then attach the foam tape to the upper door panel.

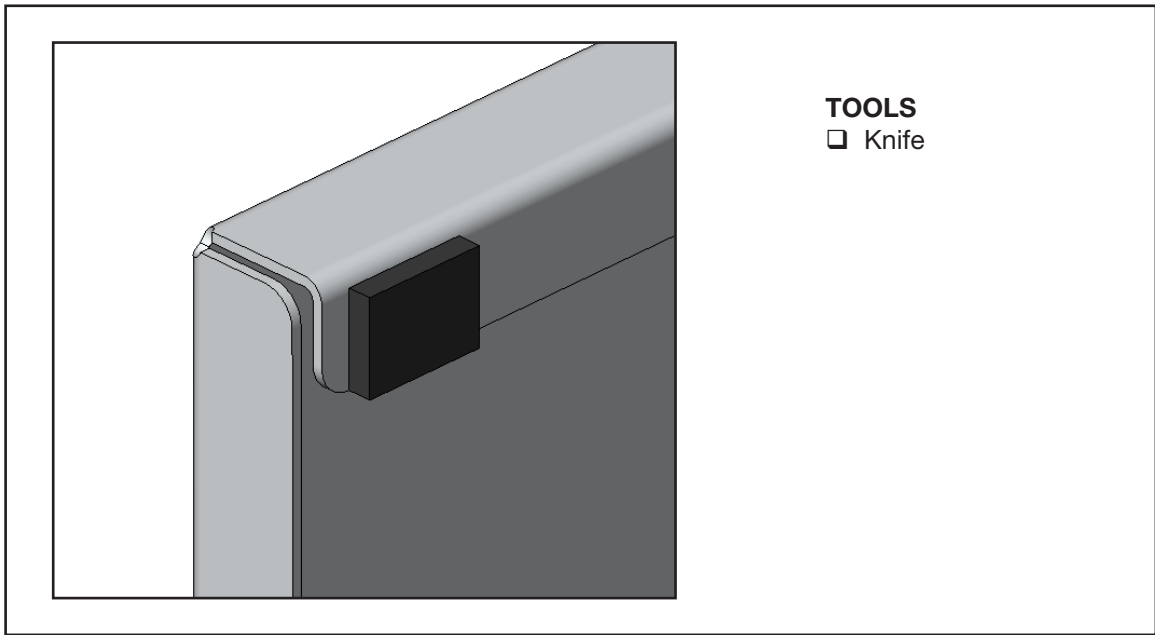
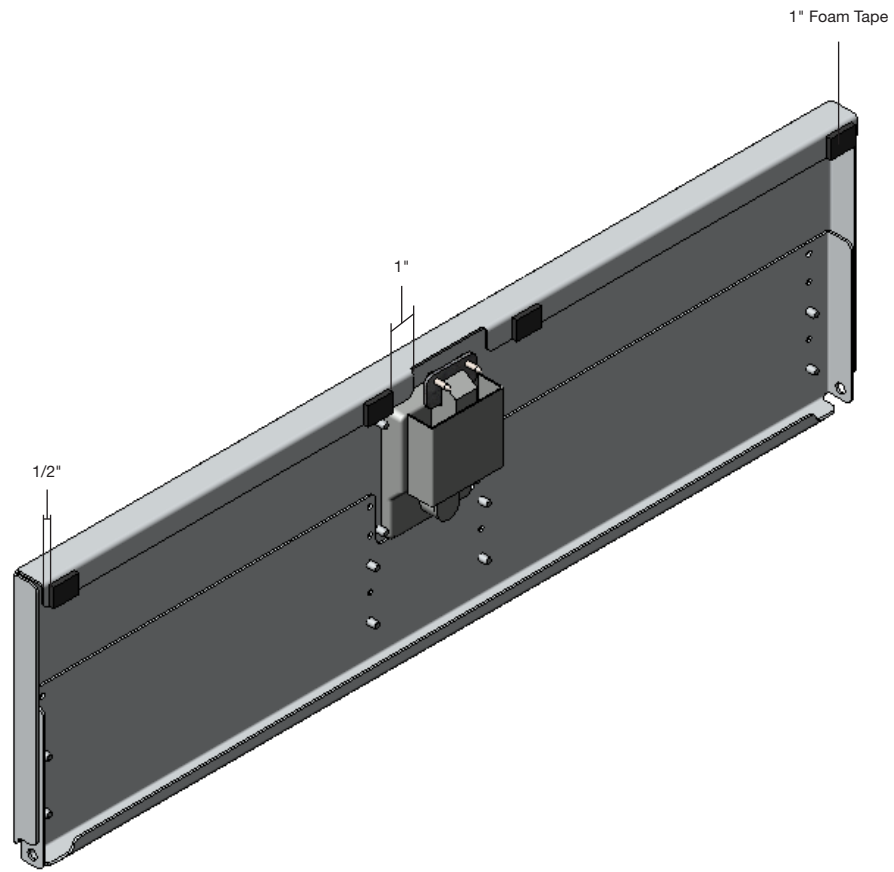

# PHASE 2 – INSTALLATION

## 2.1 DOOR INSTALLATION

2.1.1 Attach the brackets to the end panels.

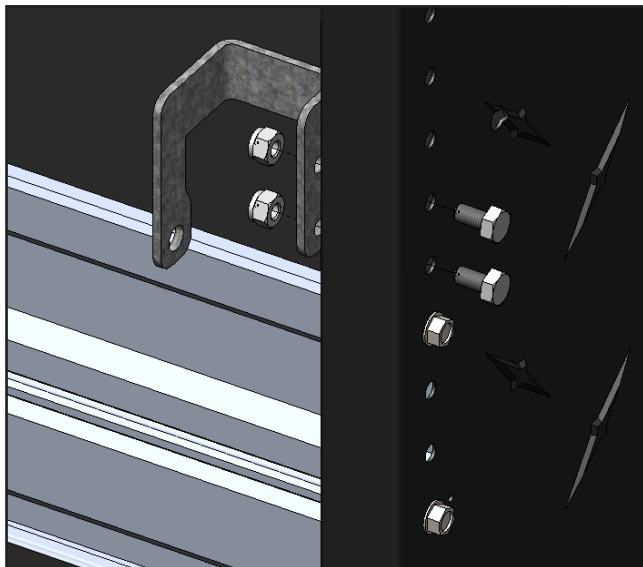
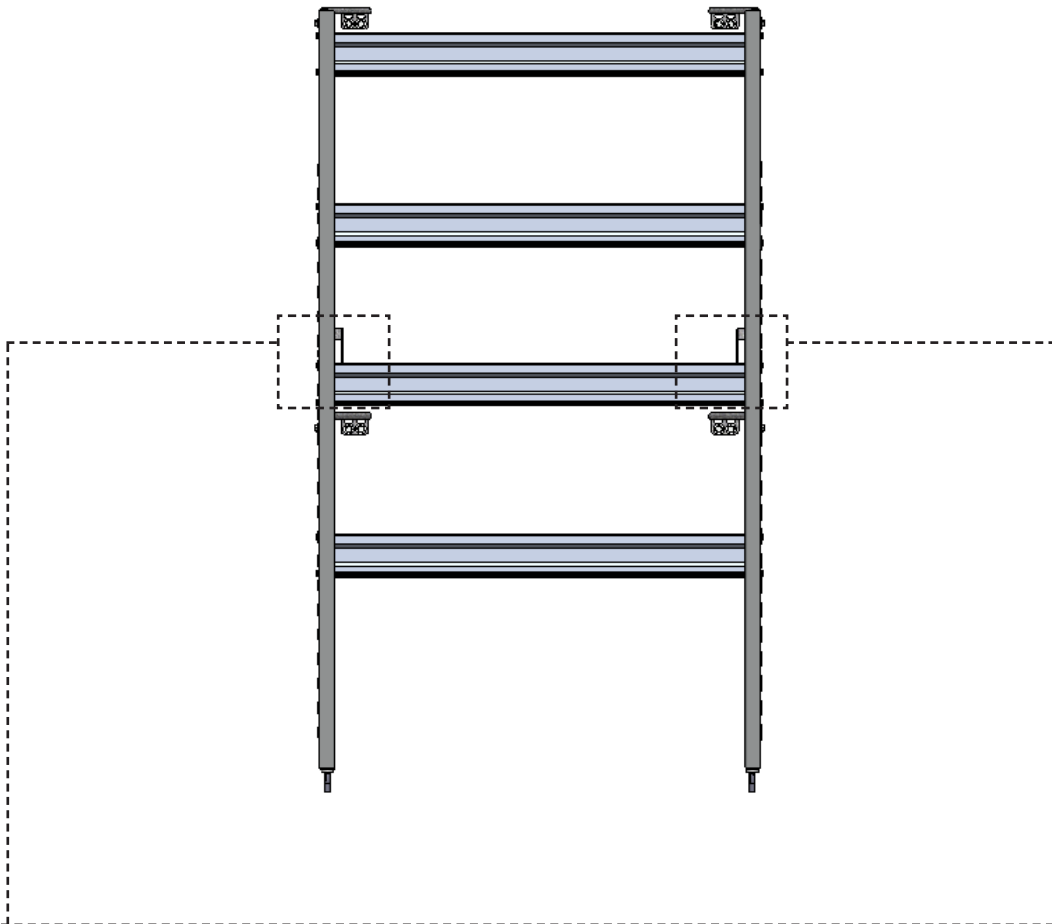



### TOOLS

- Ratchet
- 7/16" Socket
- 7/16" Wrench

### HARDWARE USED

**4x**

	#90-106 Hex Bolt 1/4" x 1/4"
	#94-106 Lock Nut

2.1.2 Attach the door to the brackets.

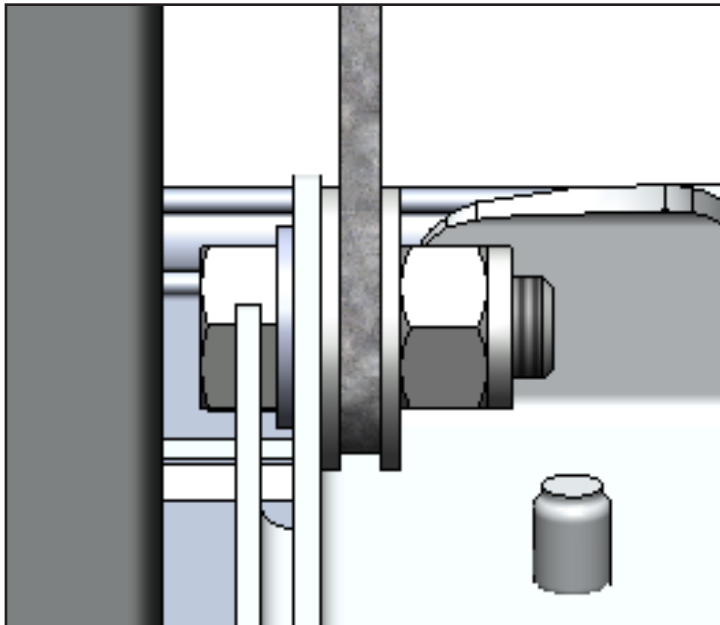
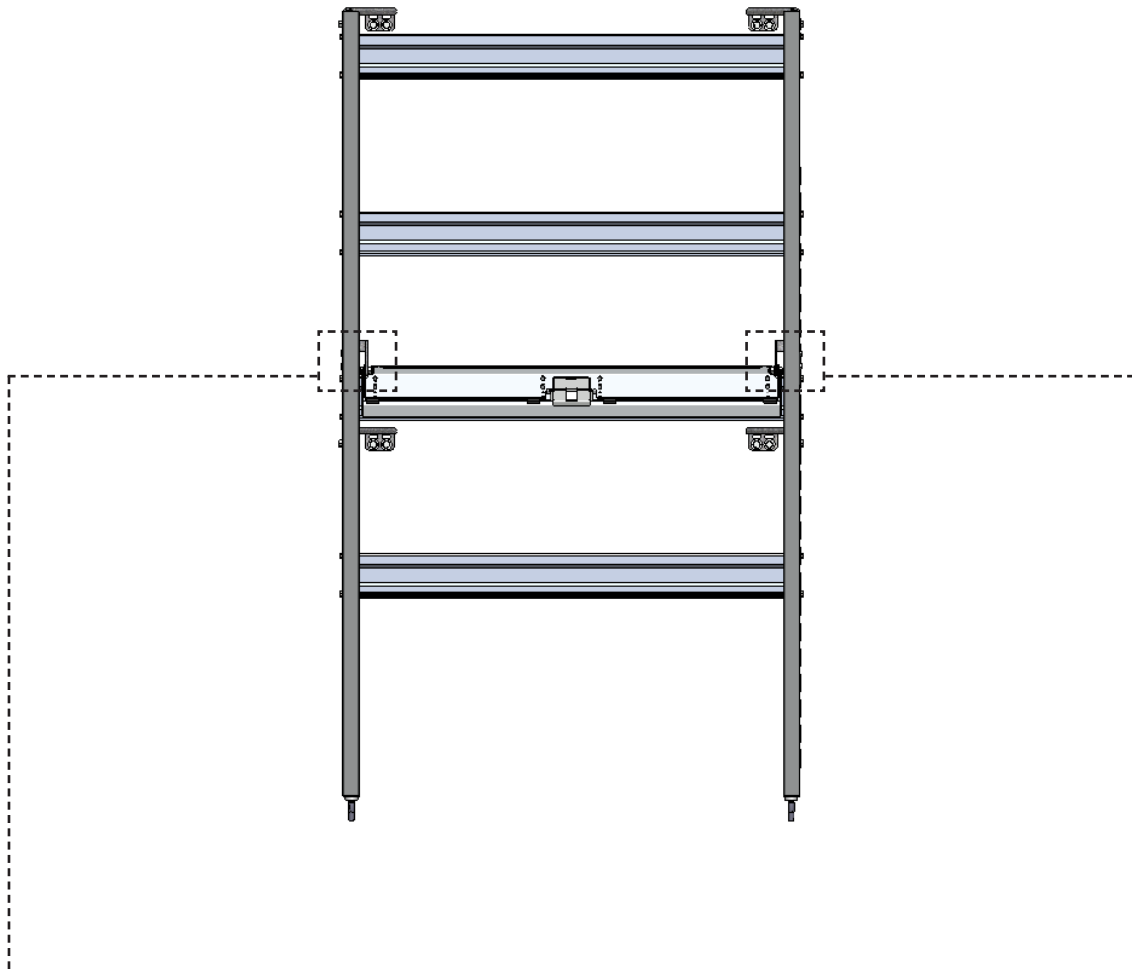





**NOTE:** Do not over tightened the bolts, make sure that the door works smoothly.

**TOOLS**

- 1/2" Wrench (2x)

**HARDWARE USED**

**2x**

-  #90-206 Hex Bolt 5/16" x 7/8"
-  #98-134 Shoulder Washer
-  #98-116 Flat Washer
-  #98-116 Flat Washer
-  #94-110 Lock Nut



2.1.3 Attach the door brackets to the end panel, then attach doors to the end panel and center post.



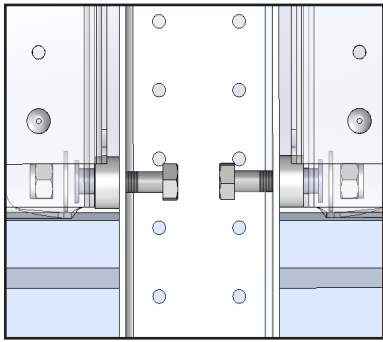
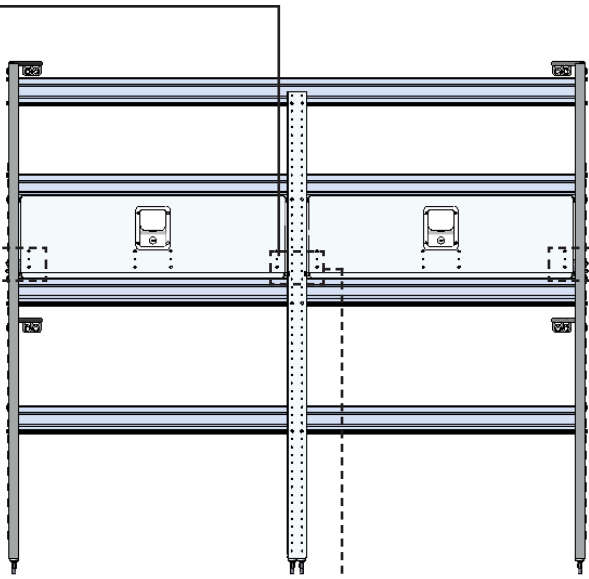

**DOOR INSTALLATION IN SHELF W/ CENTER POST**

**NOTE:** don't use door brackets on this end of the door.



**TOOLS**  
 □ 1/2" Wrench x2

**HARDWARE USED**  
**2x**

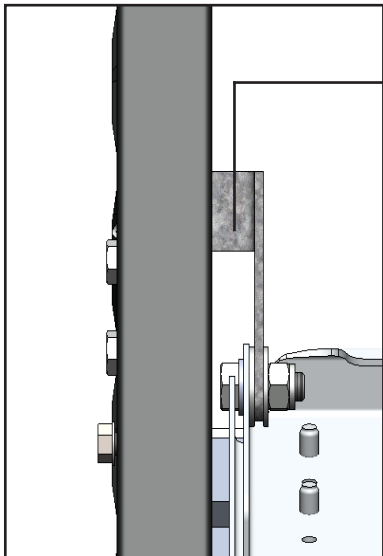

-  #90-212 Hex Bolt 5/16" x 1-1/4"
-  #98-143 Nylon Spacer
-  #98-134 Shoulder Washer
-  #98-116 Flat Washer
-  #94-110 Lock Nut







Attach the brackets 1st to the end panels before attaching the door panel to the brackets.

**TOOLS**  
 □ 1/2" Wrench (2x)  
 □ 7/16" Wrench (2x)

**HARDWARE USED**  
**4x**

-  #90-106 Hex Bolt 1/4" x 1/4"
-  #94-106 Lock Nut

**HARDWARE USED**  
**2x**

-  #90-206 Hex Bolt 5/16" x 7/8"
-  #98-134 Shoulder Washer
-  #98-116 Flat Washer
-  #98-116 Flat Washer
-  #94-110 Lock Nut

# PHASE 2 – INSTALLATION

## 2.2 STRIKER PLATE INSTALL

2.2.1 Screw the striker plate to the shelf tray extrusion.

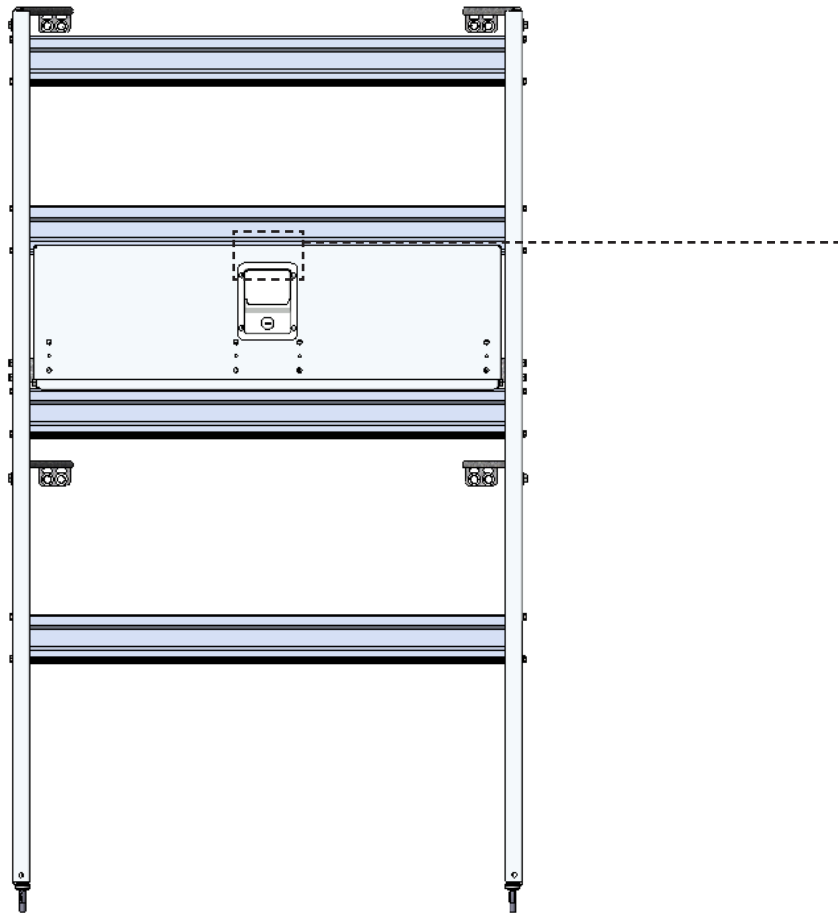

70 - 961

Center of the latch

**TOOLS**

- Cordless Impact
- 3/8" Driver Bit

**HARDWARE USED**

**2x**

	#92-200 Screw #10 - 16 x 3/4"
---	-------------------------------

The diagram shows a close-up of the shelf tray extrusion. A horizontal line points to the center of the latch mechanism. Below the latch, a rectangular hole is visible, which is the location for the #92-200 screw. The diagram is enclosed in a dashed border.

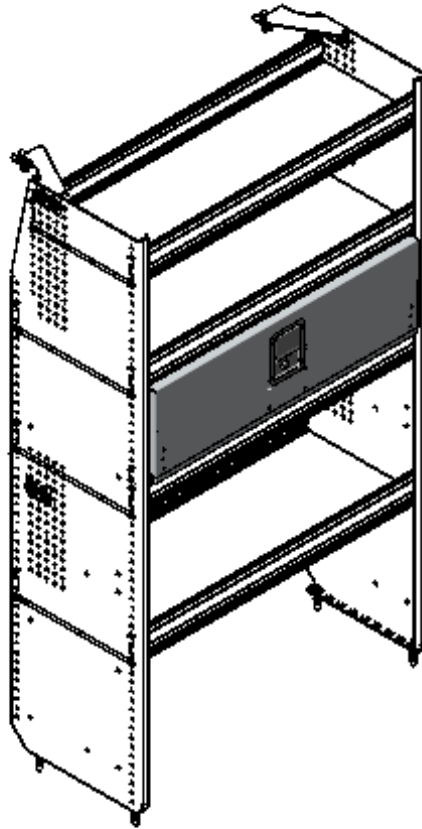

**“You have successfully installed your  
77-U1036**

**Thank you for doing business with us.”**

For any feedback or suggestions you may have, please contact: [cs@rangerdesign.com](mailto:cs@rangerdesign.com)

