

INSTALLATION GUIDE

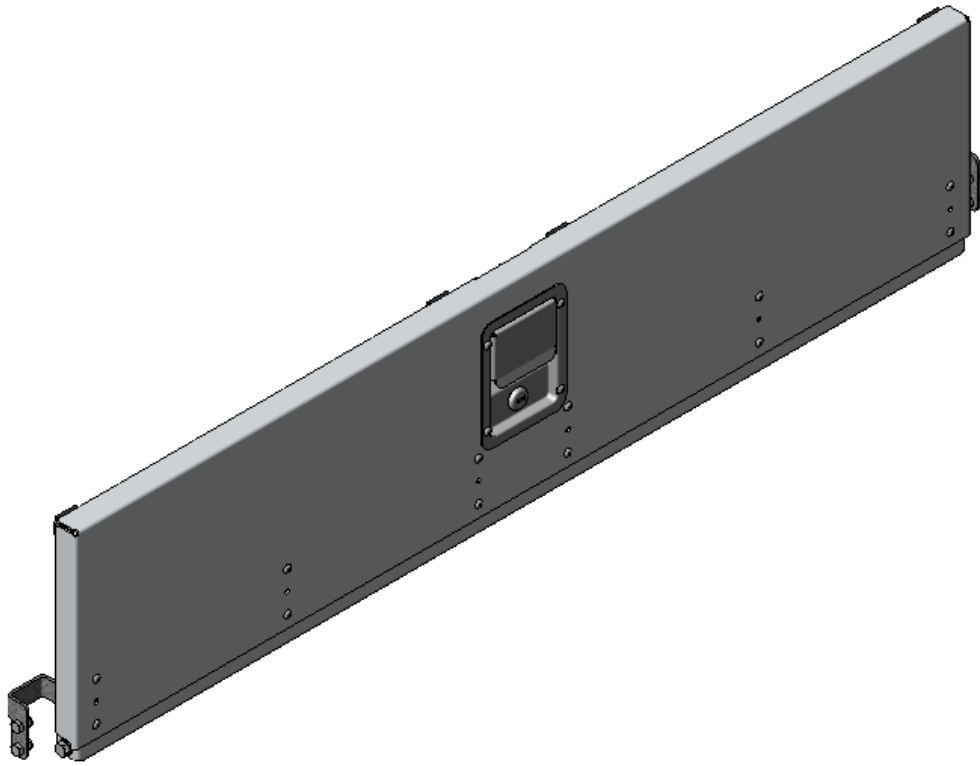

77-U1048 Shelving Door (ALUMINUM)

QUICK START GUIDE

Phase 1 - Assembly

- 1.1 Setup..... 3 - 4
- 1.2 Door Assembly..... 5 - 6

Phase 2 - Installation

- 2.1 Door Installation..... 7 - 9
- 2.2 Striker Plate Install..... 10

REQUIRED ITEMS

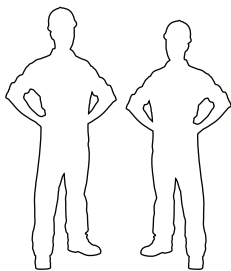

2
PERSONS

- Ratchet
- Rivet Gun
- Tape Measure
- Marker
- 1/2" Socket
- 7/16" Socket
- 7/16" Wrench
- 1/2" Wrench
- Knife

PHASE 1 – ASSEMBLY

1.1 SETUP

1.1.1 Unpack components; compare with the bill of materials.

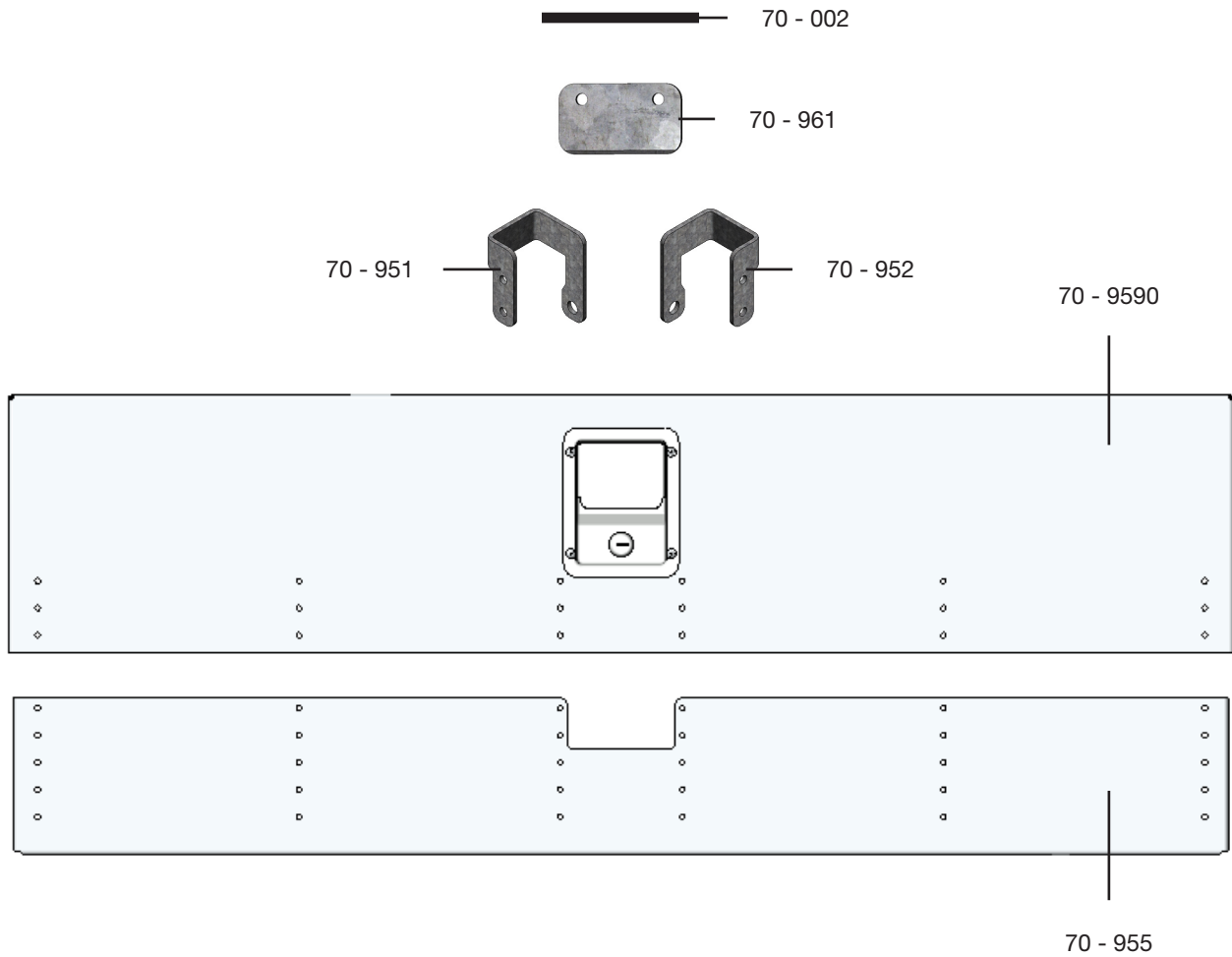

1.1.2 Verify all parts are present.

BILL OF MATERIALS

| Item No. | Description | Qty. |
|-----------|------------------------------|------|
| 70-002 | Foam Tape (QTY in Inches) | 4 |
| 70 - 951 | Door Bracket (Left) | 1 |
| 70 - 952 | Door Bracket (Right) | 1 |
| 70 - 955 | Lower Door Panel | 1 |
| 70 - 961 | Striker Plate | 1 |
| 70 - 9590 | Upper Panel w/ Latch (48") | 1 |
| 94 - 4031 | Assembly Fastener Kit | 1 |
| 96 - 4029 | Install Fastener Kit | 1 |

1.1.3 Fastener kits.



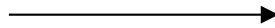

94 - 4031 Fastener Kit



Fastener Assembly

- 2x**  **# 90-206** Hex Bolt
5/16"-18 x 7/8"
GR-5 ZINC
- 2x**  **# 94-110** Lock Nut
5/16"
ZINC
- 12x**  **# 96-202** Closed End Blind Rivet
3/16" Type #64
- 2x**  **# 98-134** Shoulder Washer
5/16"
NYLON
- 4x**  **# 98-116** Flat Washer
5/16"
ZINC

2x

 #90-206 Hex Bolt 5/16" x 7/8"
 #98-134 Shoulder Washer
 #98-116 Flat Washer
 #98-116 Flat Washer
 #94-110 Lock Nut



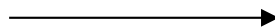

12x

 #96-202 Closed End Blind Rivet



96 - 4029 Fastener Kit



Fastener Assembly

- 1x**  **# 90-212** Hex Bolt
5/16"-18 x 1 - 1/4"
GR-5 ZINC
- 4x**  **# 90-106** Hex Bolt
1/4"-20 x 1/2"
GR-5 ZINC
- 4x**  **# 94-106** Lock Nut
1/4"
ZINC
- 2x**  **# 92-200** Screw HFH
#10 - 16 x 3/4"
ZINC
- 1x**  **# 98-143** Spacer
.38" ID x .875" OD x .375" L
Nylon

4x

 #90-106 Hex Bolt 1/4" x 1/4"
 #94-106 Lock Nut

2x

 #92-200 Screw #10 - 16 x 3/4"

PHASE 1 – ASSEMBLY

1.2 DOOR ASSEMBLY

1.2.1 Attach the lower door panel to the upper door panel.

NOTE: The height of the door depends on the height between the two shelf trays.

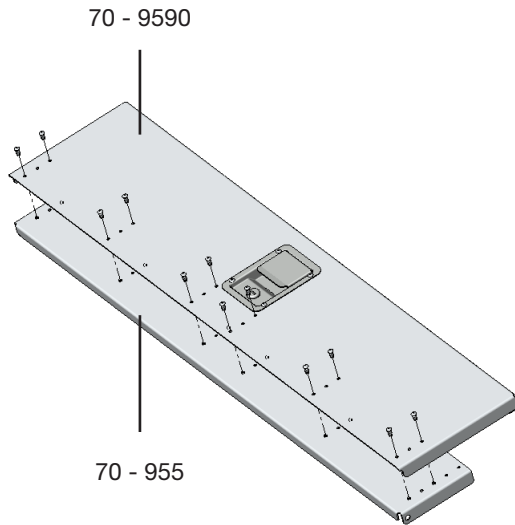

10 - 5/16" Door is for 13" height between two shelf trays or 9 holes.

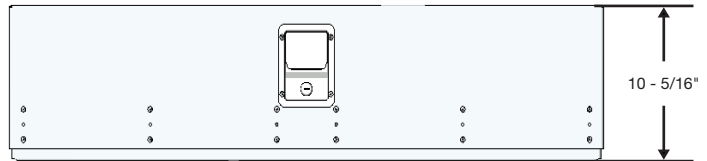

11 - 5/16" Door is for 14" height between two shelf trays or 10 holes.

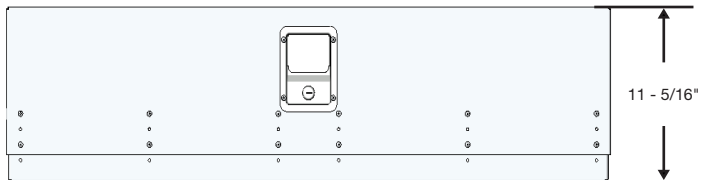

12 - 5/16" Door is for 15" height between two shelf trays or 11 holes.

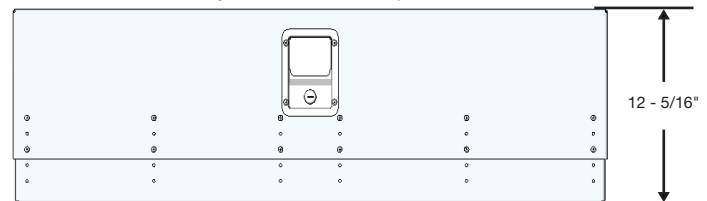

13 - 5/16" Door is for 16" height between two shelf trays or 12 holes.

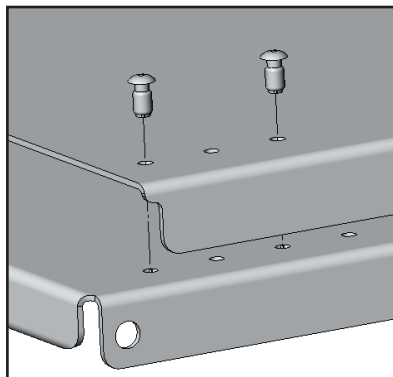
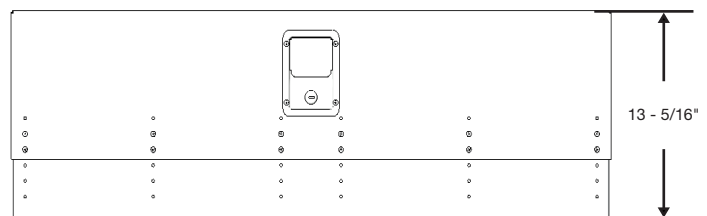

TOOLS

- Rivet Gun

HARDWARE USED

12x



#96-202 Closed End Blind Rivet

1.2.2 Cut the foam tape into 4 pieces of 1", then attach the foam tape to the upper door panel.

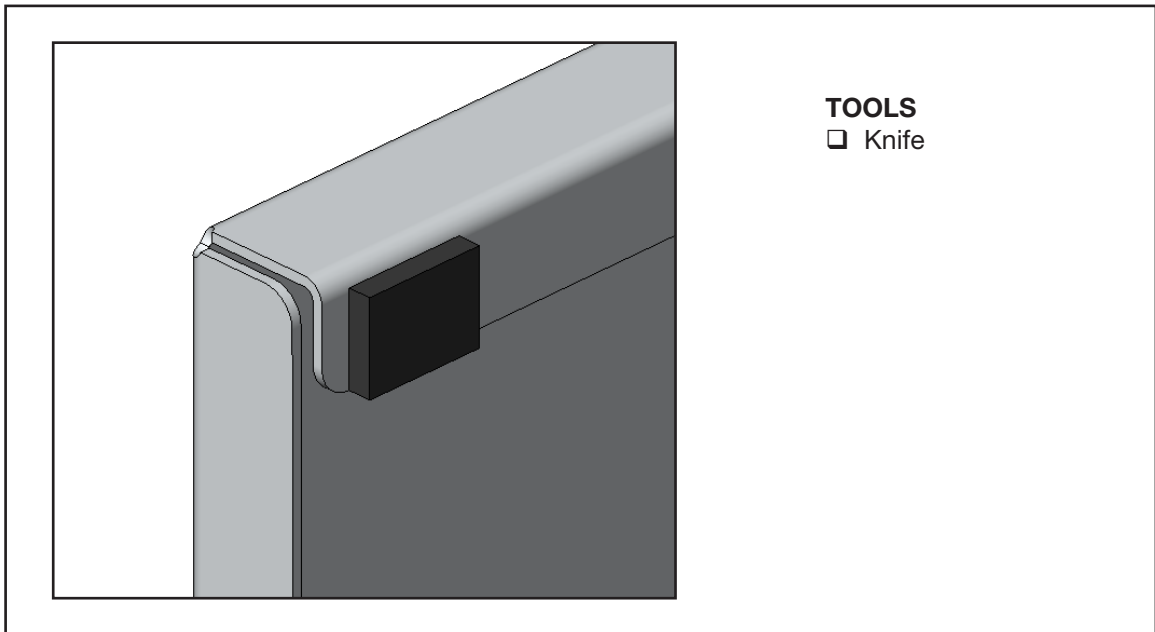
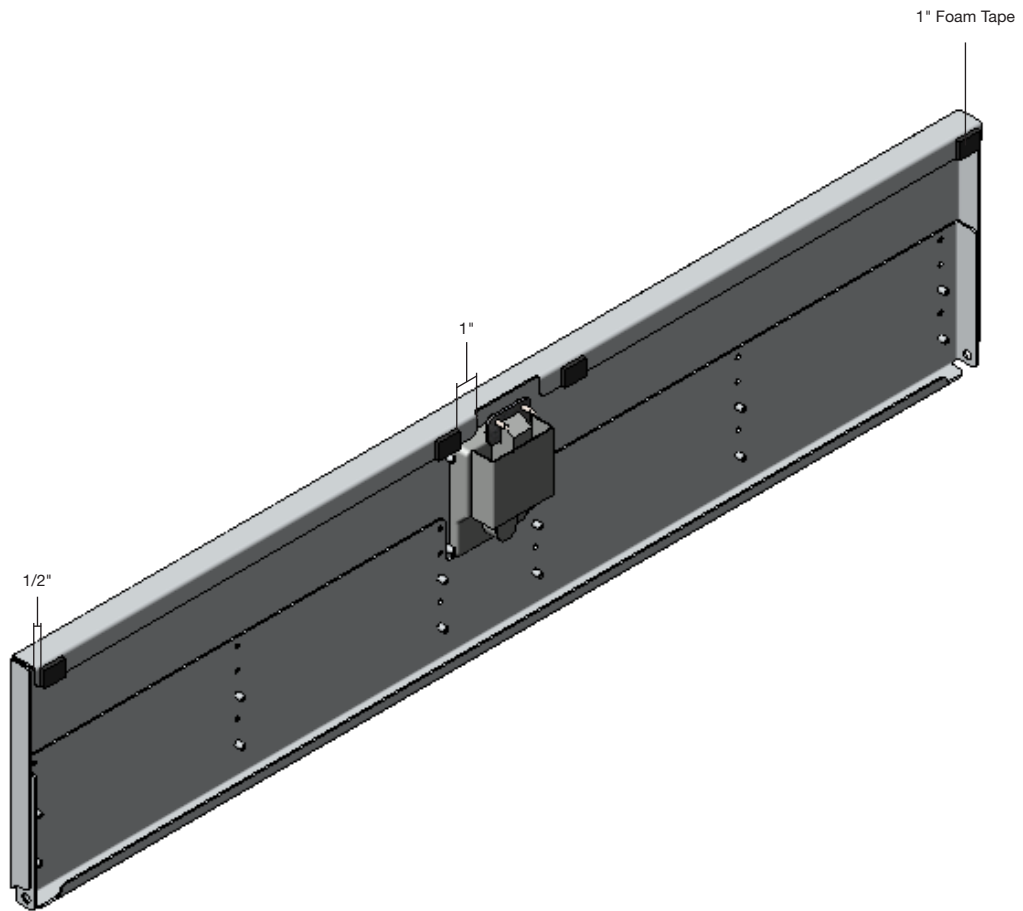

PHASE 2 – INSTALLATION

2.1 DOOR INSTALLATION

2.1.1 Attach the brackets to the end panels.

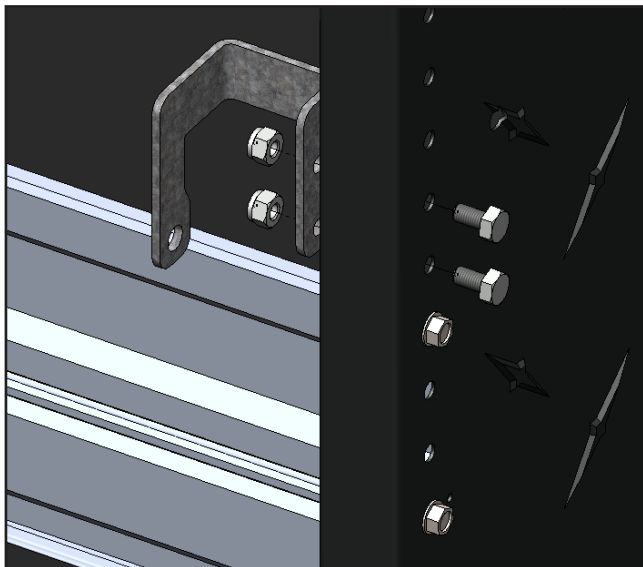
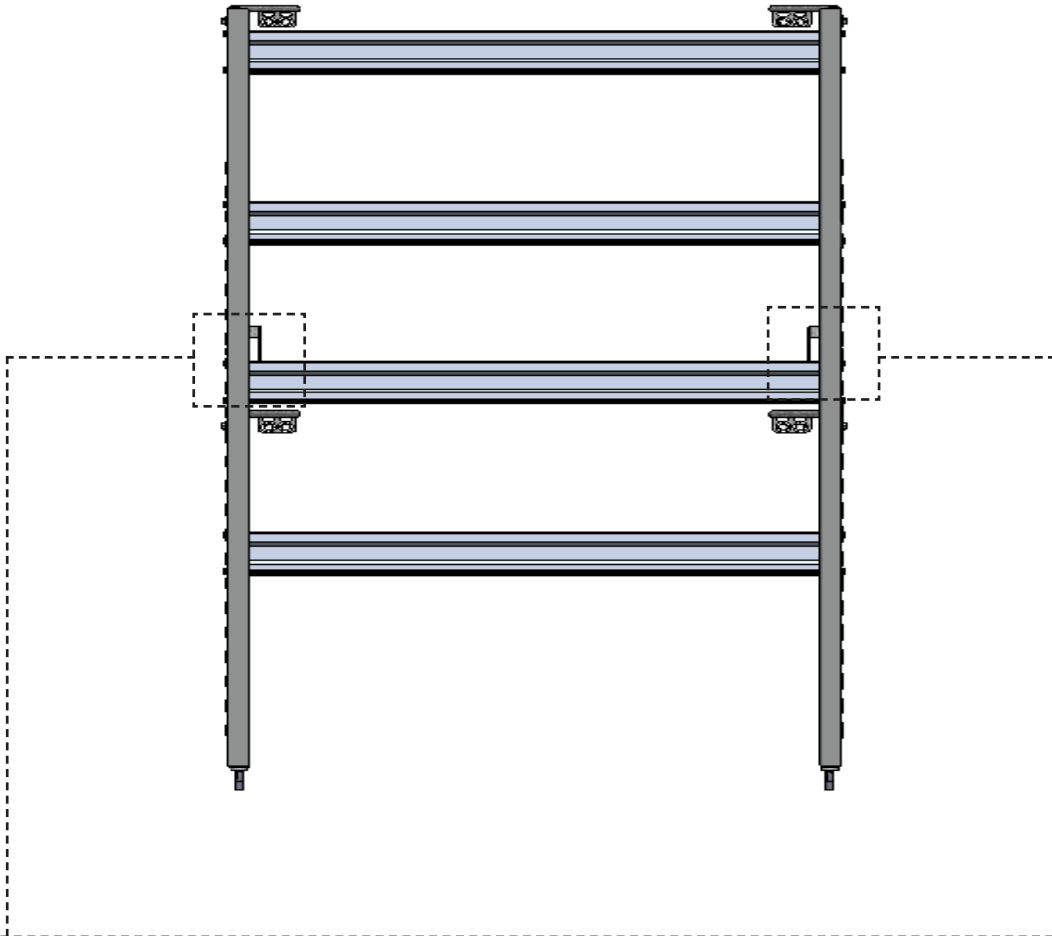



TOOLS

- Ratchet
- 7/16" Socket
- 7/16" Wrench

HARDWARE USED

4x

| | |
|---|------------------------------|
|  | #90-106 Hex Bolt 1/4" x 1/4" |
|  | #94-106 Lock Nut |

2.1.2 Attach the door to the brackets.

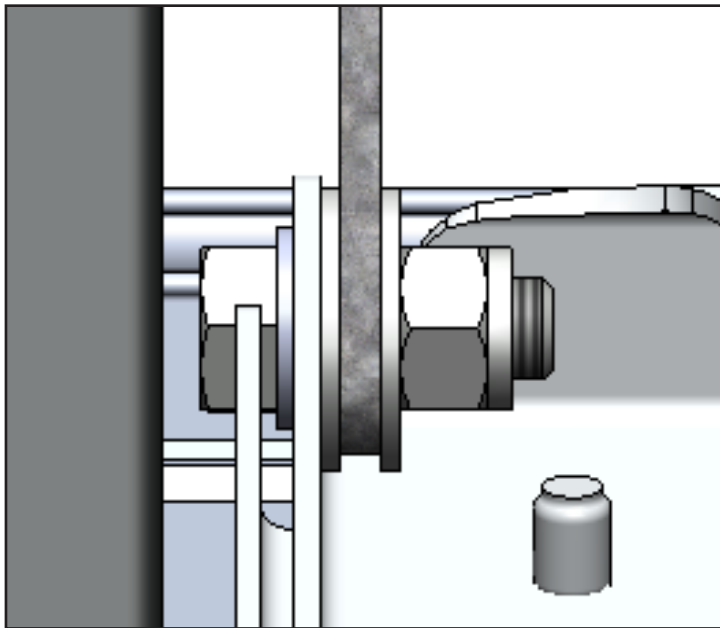
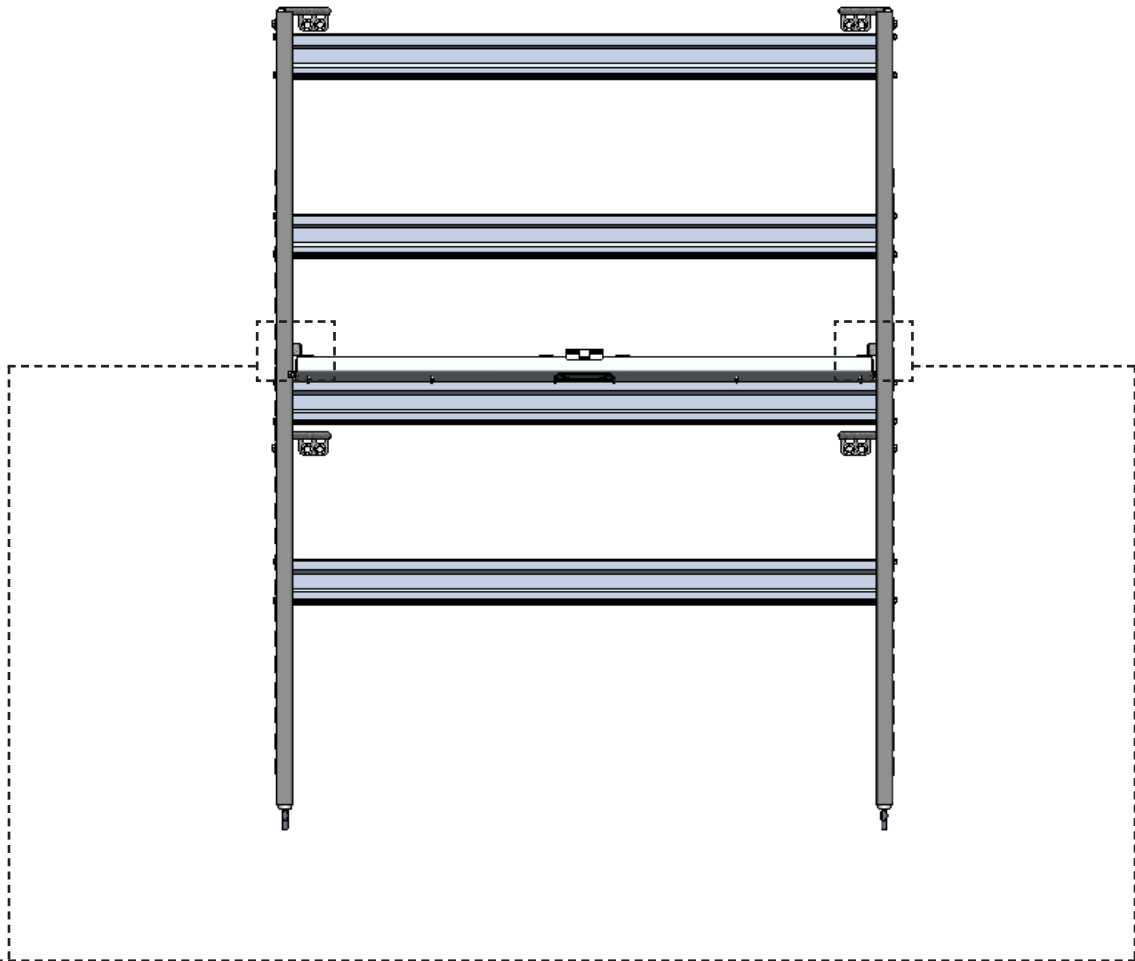





NOTE: Do not over tightened the bolts, make sure that the door works smoothly.

TOOLS

- 1/2" Wrench (2x)

HARDWARE USED

2x

-  #90-206 Hex Bolt 5/16" x 7/8"
-  #98-134 Shoulder Washer
-  #98-116 Flat Washer
-  #98-116 Flat Washer
-  #94-110 Lock Nut

2.1.3 Attach the door brackets to the end panel, then attach doors to the end panel and center post.

DOOR INSTALLATION IN SHELF W/ CENTER POST

NOTE: don't use door brackets on this end of the door.

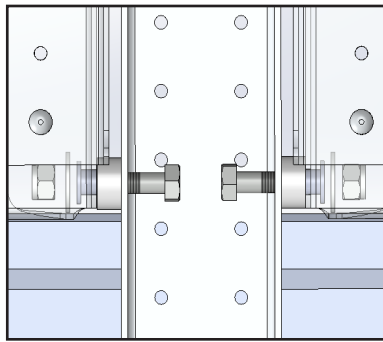
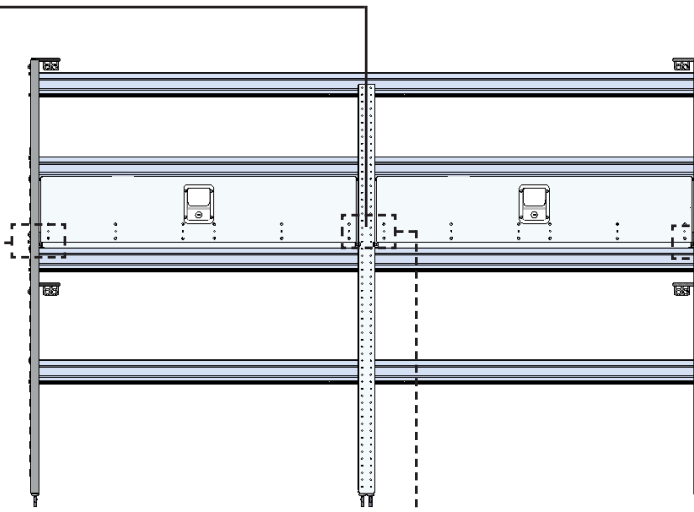

TOOLS
 □ 1/2" Wrench x2

HARDWARE USED
2x

- #90-212 Hex Bolt 5/16" x 1-1/4"
- #98-143 Nylon Spacer
- #98-134 Shoulder Washer
- #98-116 Flat Washer
- #94-110 Lock Nut

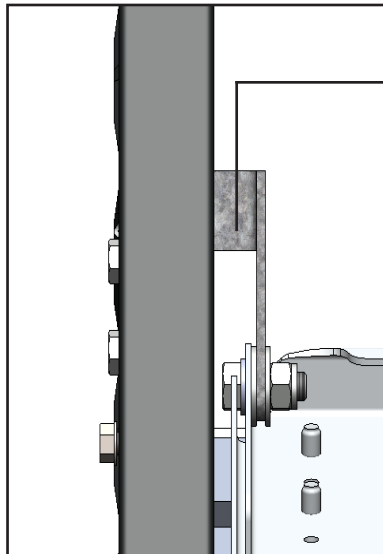

Attach the brackets 1st to the end panels before attaching the door panel to the brackets.

TOOLS
 □ 1/2" Wrench (2x)
 □ 7/16" Wrench (2x)

HARDWARE USED
4x

- #90-106 Hex Bolt 1/4" x 1/4"
- #94-106 Lock Nut

HARDWARE USED
2x

- #90-206 Hex Bolt 5/16" x 7/8"
- #98-134 Shoulder Washer
- #98-116 Flat Washer
- #98-116 Flat Washer
- #94-110 Lock Nut

PHASE 2 – INSTALLATION

2.2 STRIKER PLATE INSTALL

2.2.1 Screw the striker plate to the shelf tray extrusion.

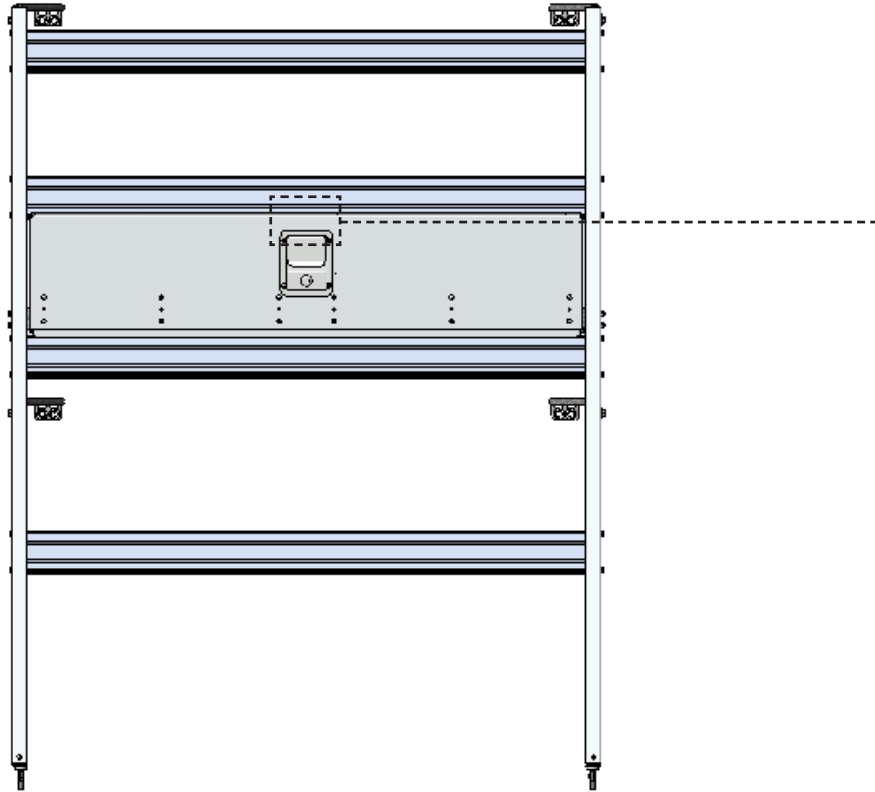

70 - 961

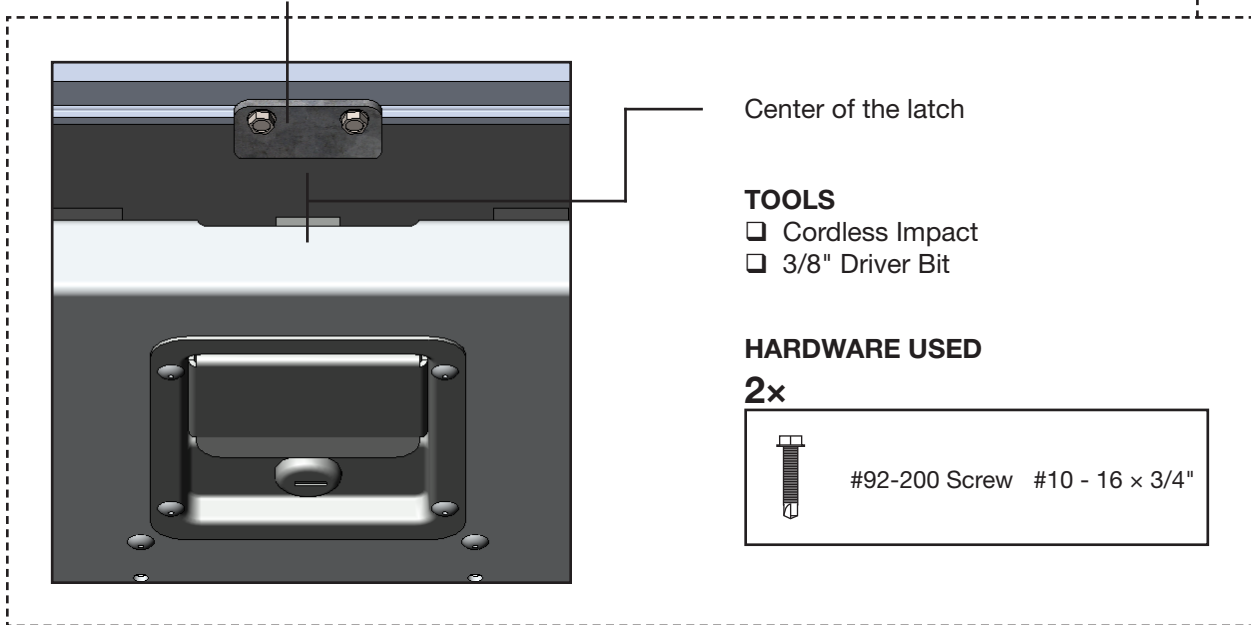

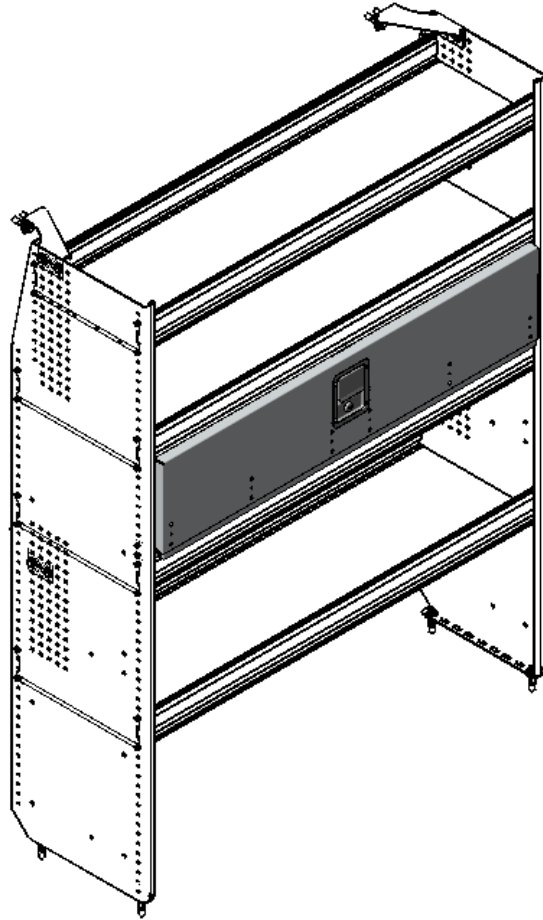

**“You have successfully installed your
77-U1048**

Thank you for doing business with us.”

For any feedback or suggestions you may have, please contact: cs@rangerdesign.com

