

PRIME DESIGN™

A Safe Fleet Brand

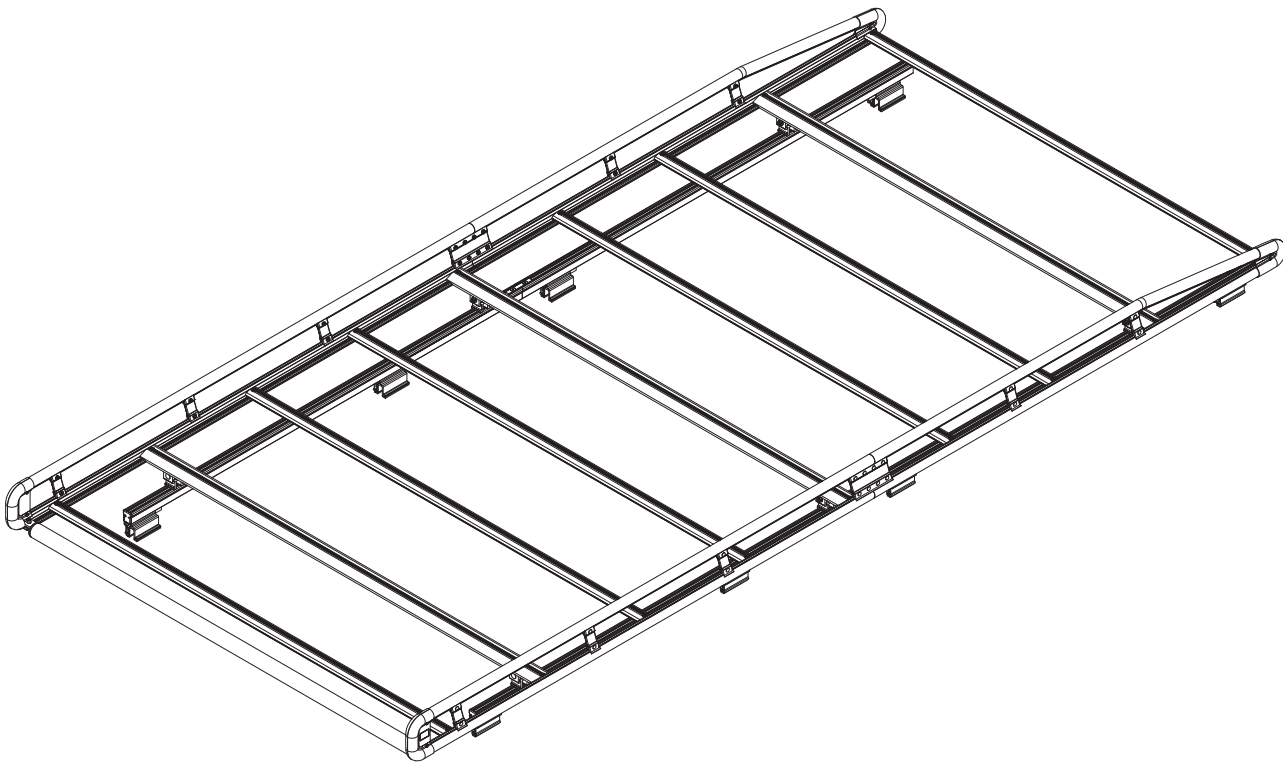

AR1423

CONTENTS OVERVIEW

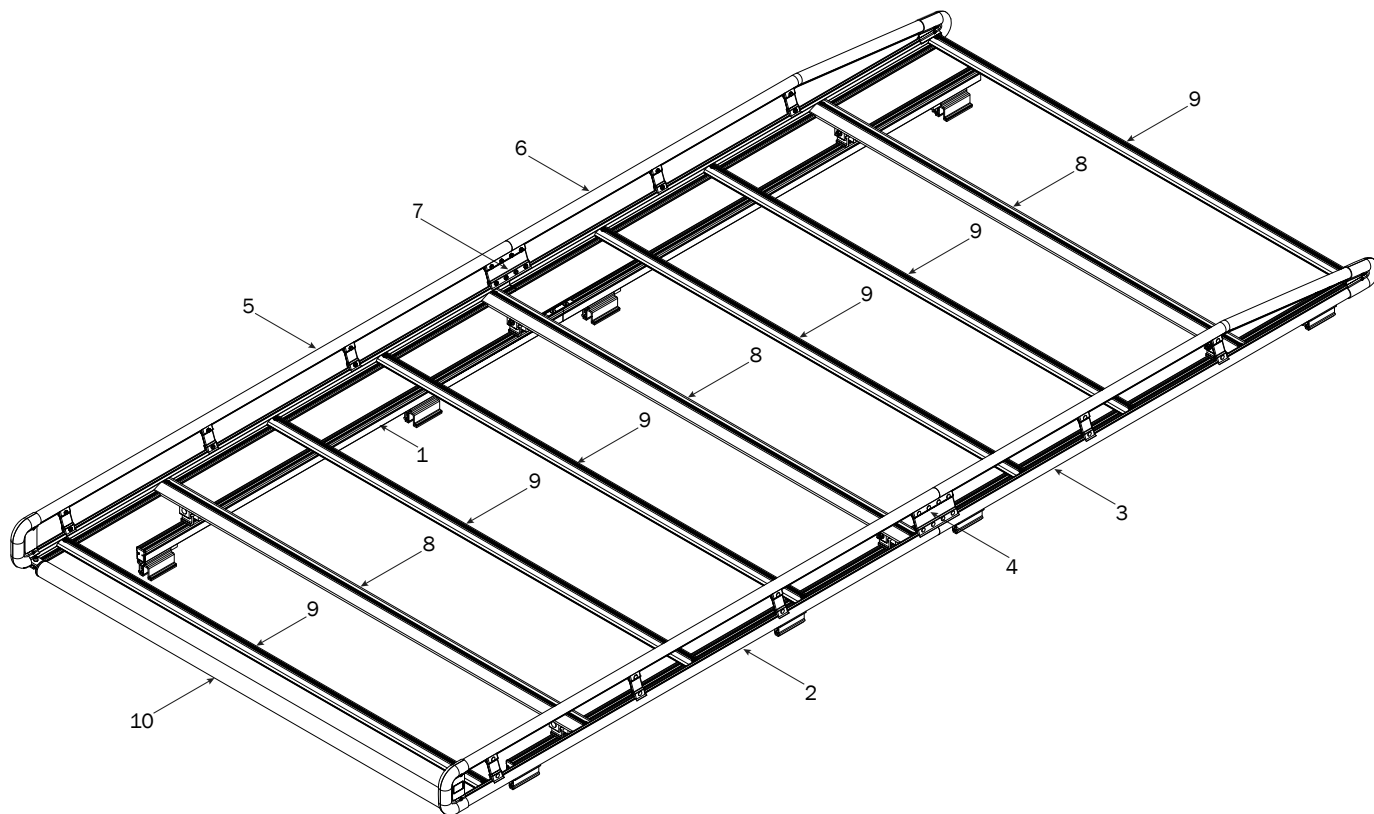

1—FBM3-0014-A (Qty 1)
Channels with hardware



Channels (4X)



End Caps (4X)



Screws (8X)



Top Connector (2X)



Bottom Connector (2X)



Brackets (6X)

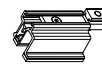

Mountings (8X)

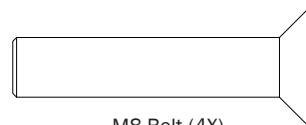

M8 Bolt (4X)

2—Side Rail Assembly (Qty 1)
Rear, Right Hand, 76.00"

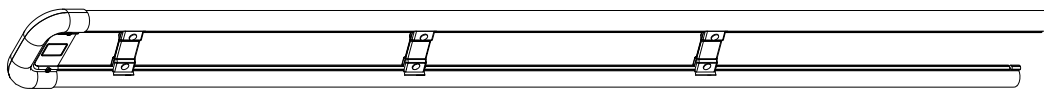

3—Side Rail Assembly (Qty 1)
Front, Right Hand, 68.00"

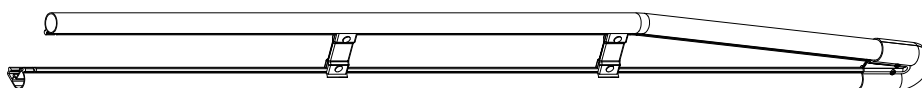

4—Side Rail Connector (Qty 1)
Right Hand, 6.00"

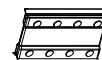

5—Side Rail Assembly..... (Qty 1)
Rear, Left Hand, 76.00"

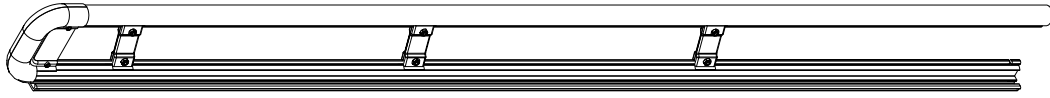

6—Side Rail Assembly..... (Qty 1)
Front, Left Hand, 68.00"

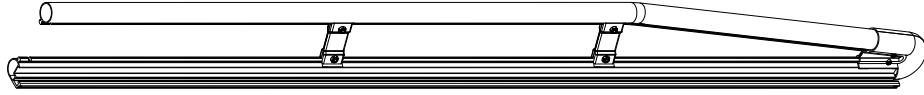

7—Side Rail Connector (Qty 1)
Left Hand, 6.00"

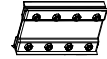

8—AluRack Construction Crossbar (Qty 3)
With hardware, 67.00"



9—AluRack Standard Crossbar (Qty 6)
With hardware, 67.00"



10—Roller Tube Assembly (Qty 1)
With caps, 63.75"



HKT-0084-Hardware Kit

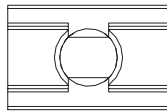

M8 Strip Nut (20X)

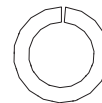

M8 Lock Washer (20X)

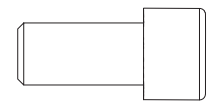

M8 Cap Head Bolt (20X)



Roller Holder (2X)



Roller Tube Pin (2X)

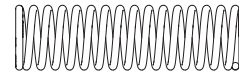

Roller Spring (2X)



Anti-Seize (1X)

FBM3-0014-A
MOUNTING BRACKETS

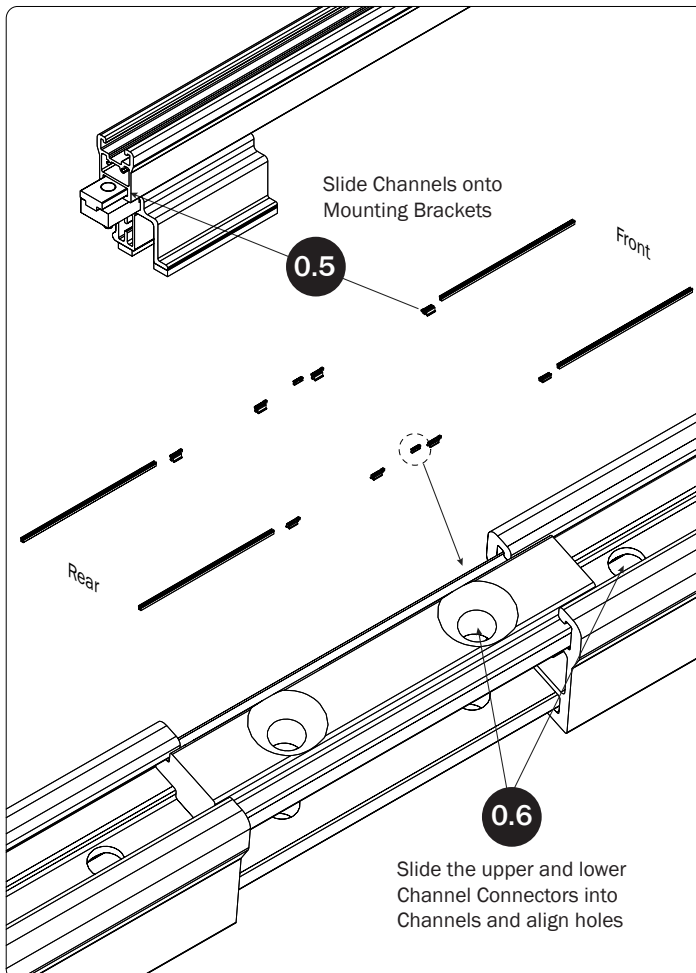
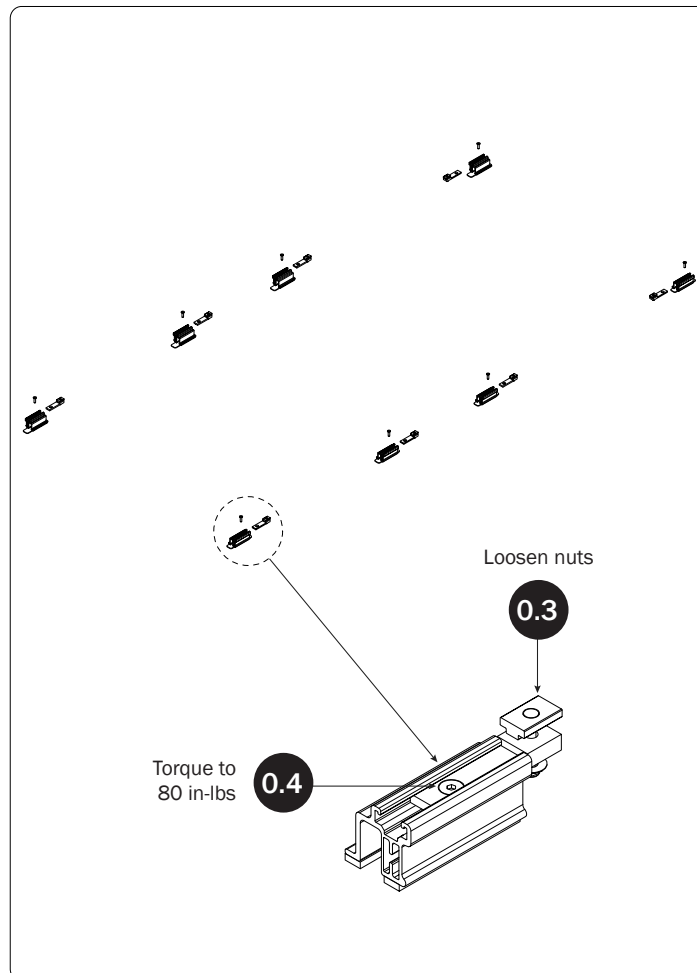
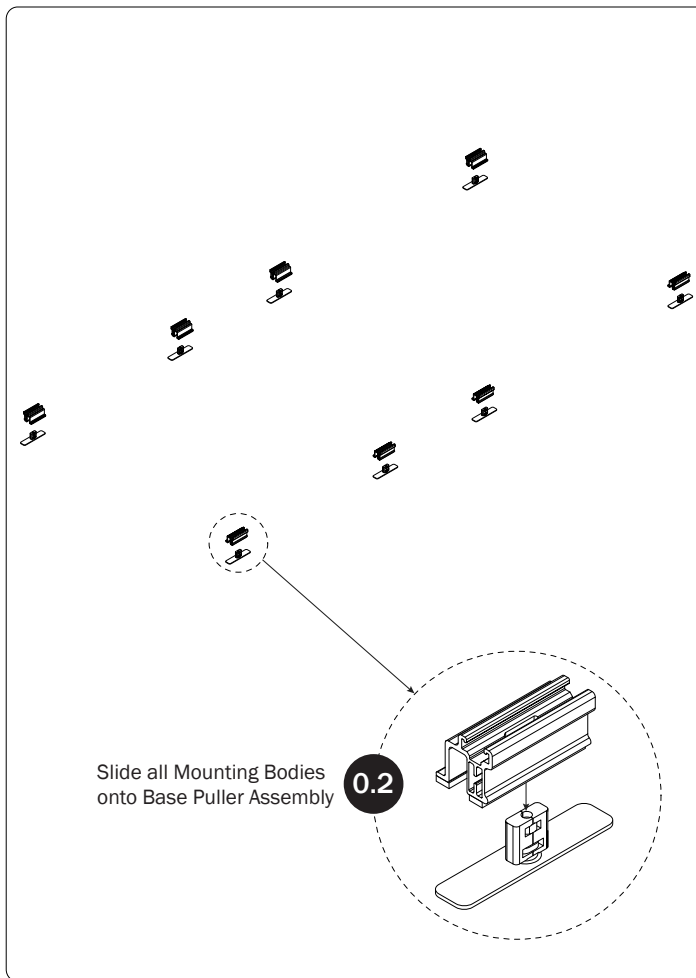
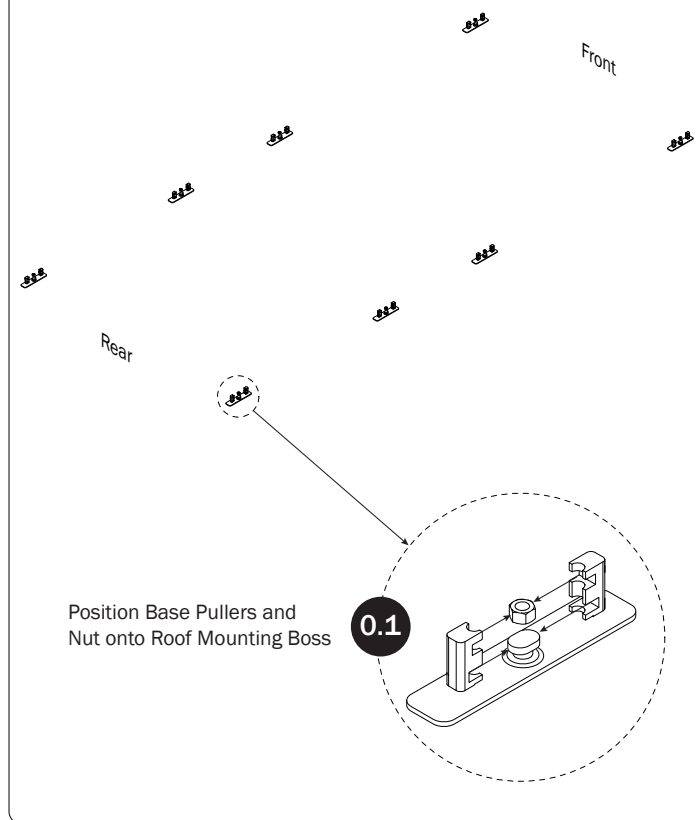

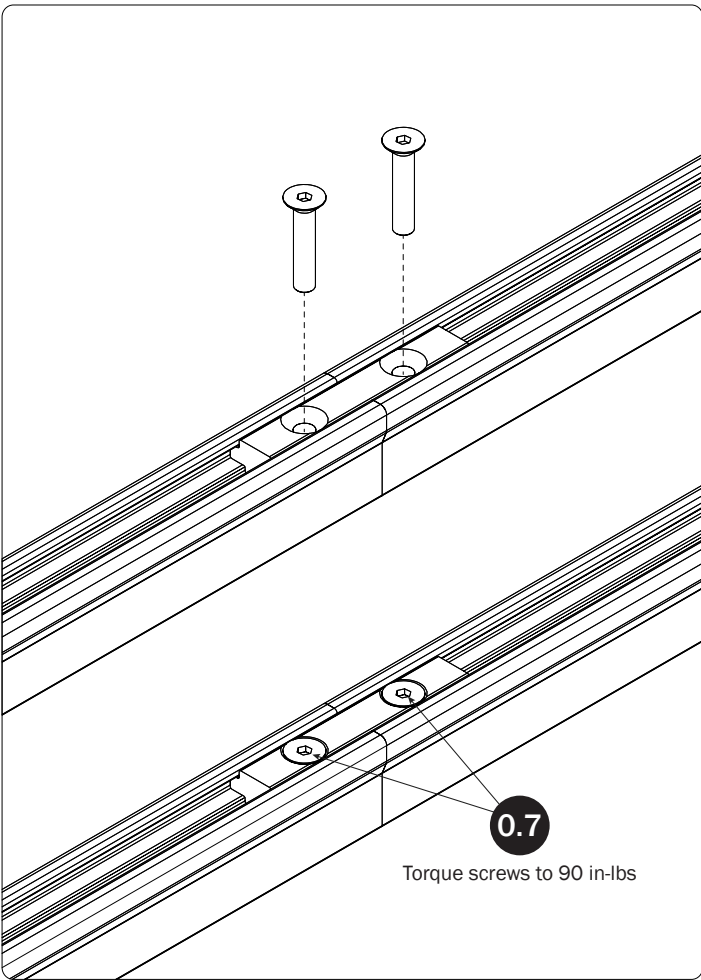

0.8 Set to distances then torque Mounting Bracket nuts to 80 in-lbs

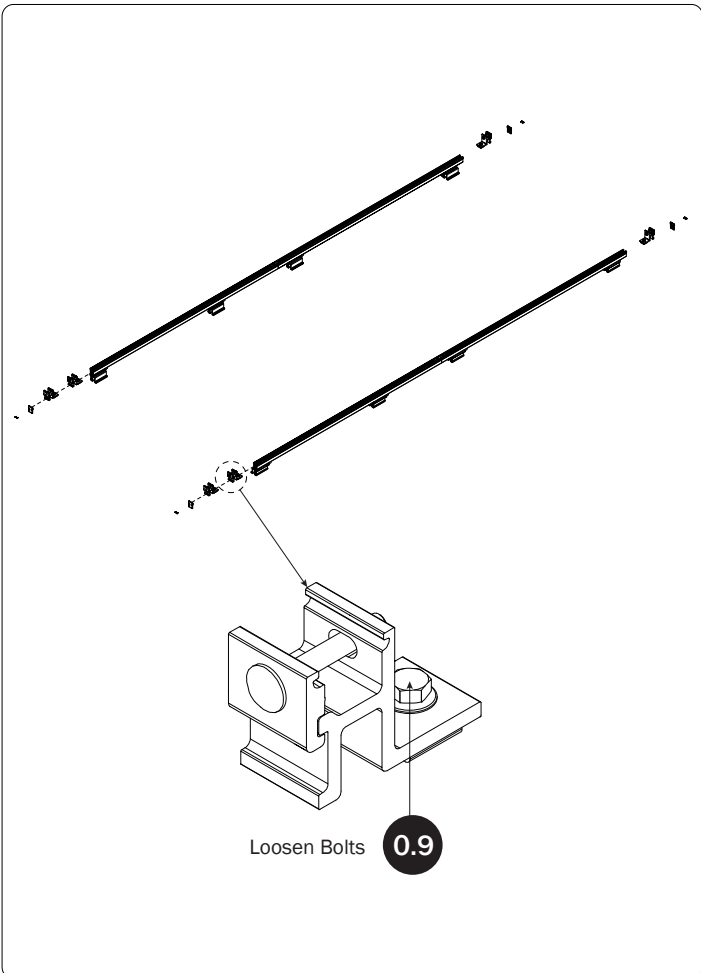
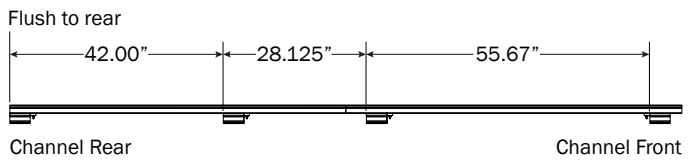

0.10 Finger-tighten to retain positions. Do not torque until Step 7.5

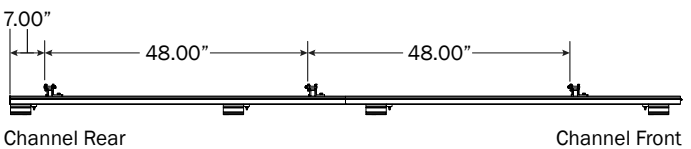

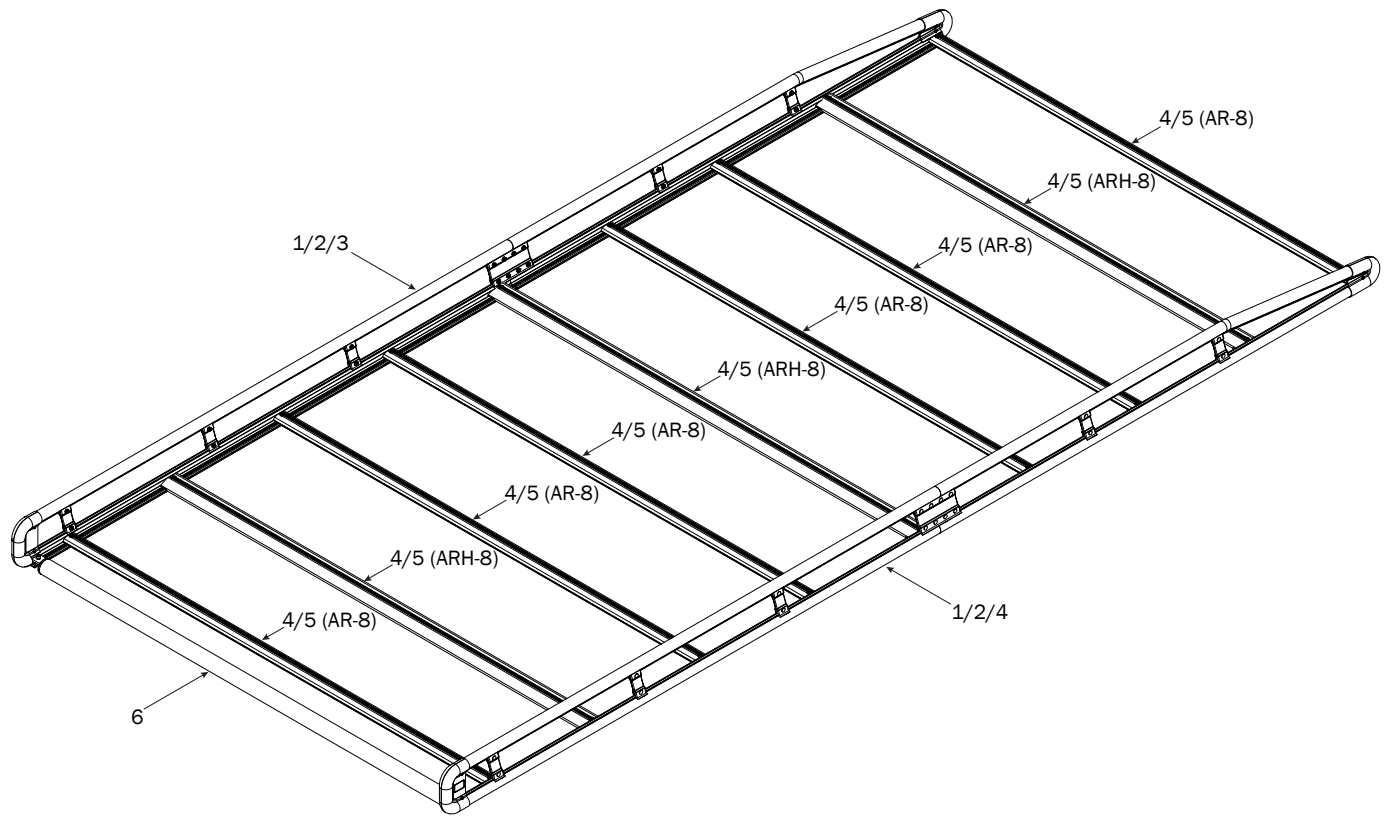
ALURACK ASSEMBLY SEQUENCE**STRIP NUT ASSEMBLY**

- 1** Insert Strip Nuts (9x) per side into Side Rails as shown

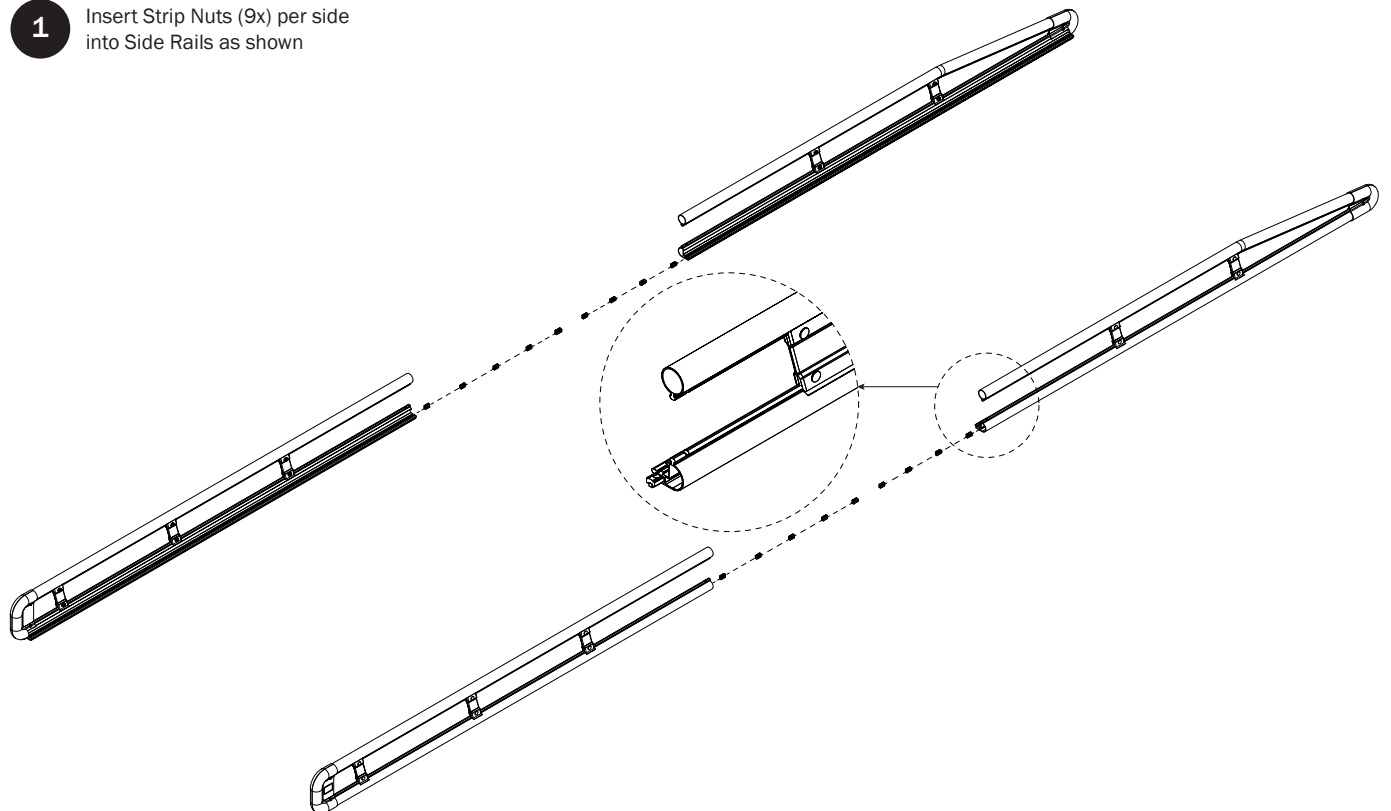

SIDE RAIL ASSEMBLY

2.1 Assemble Side rails as shown

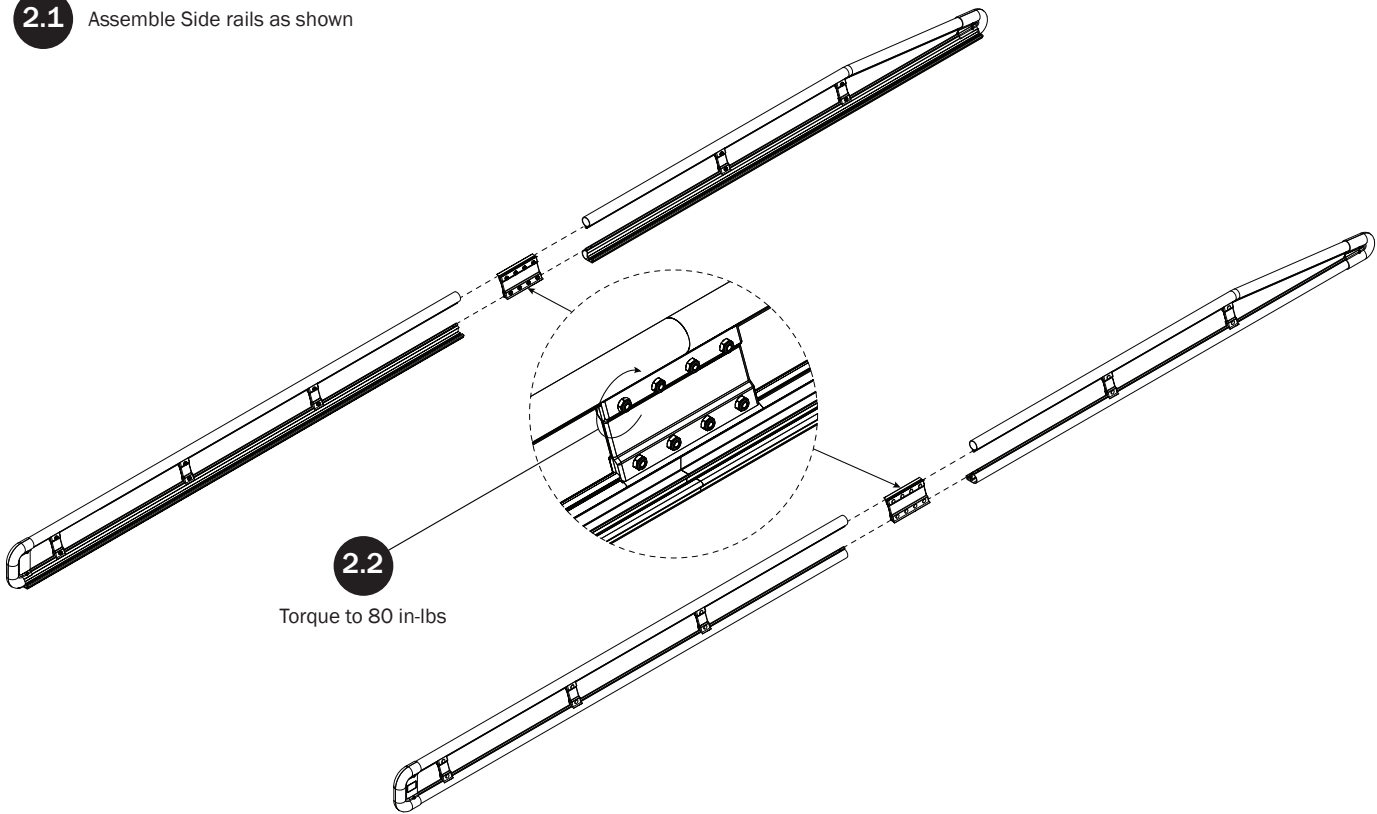

2.2
Torque to 80 in-lbs

LEFT SIDE RAIL AND CROSSBARS

3.1 Attach Crossbars to Side Rails as shown

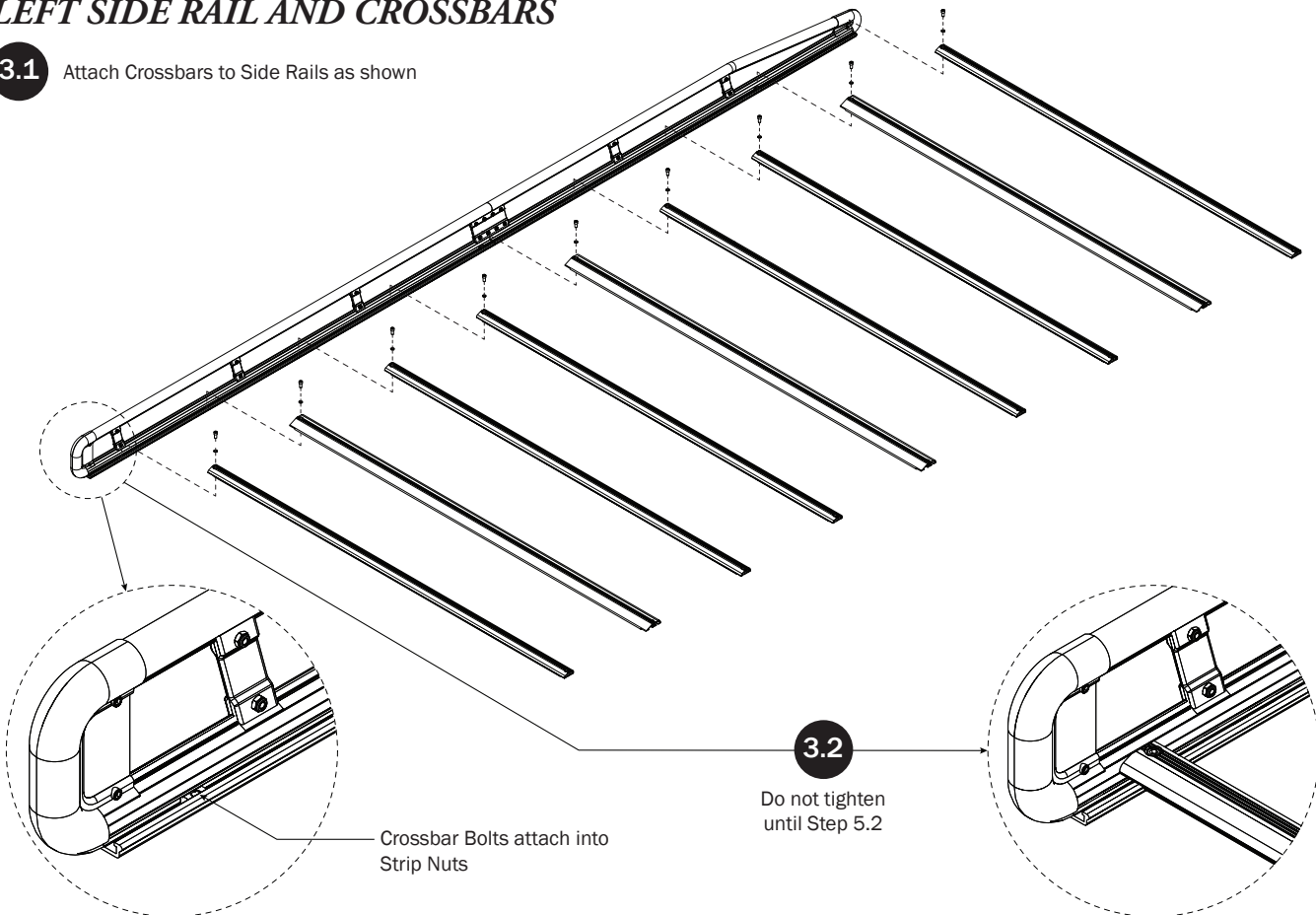

3.2
Do not tighten
until Step 5.2

Crossbar Bolts attach into
Strip Nuts

RIGHT SIDE RAIL AND CROSSBARS

4.1 Attach Crossbars to Side Rails as shown.

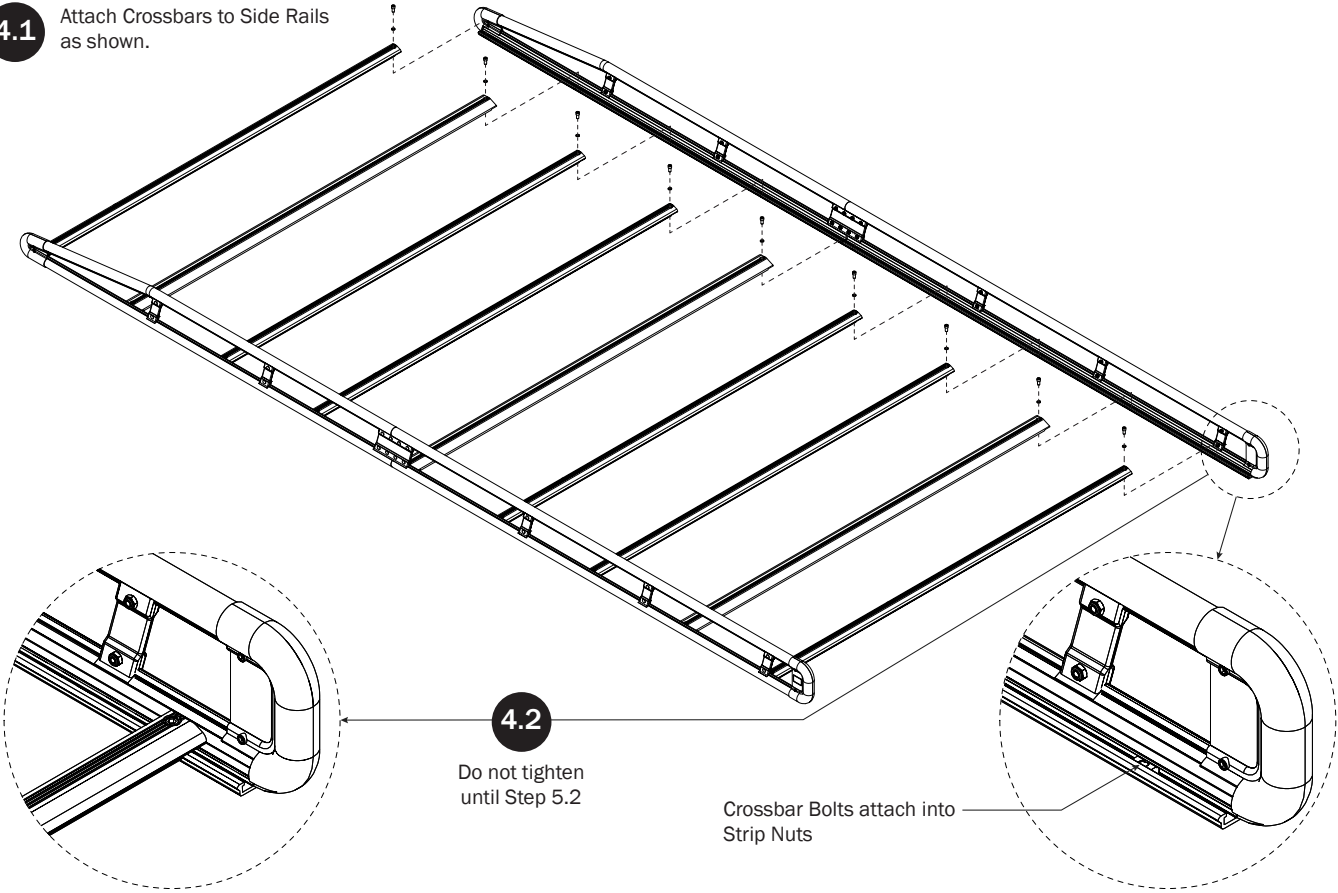

CROSSBAR ADJUSTMENT

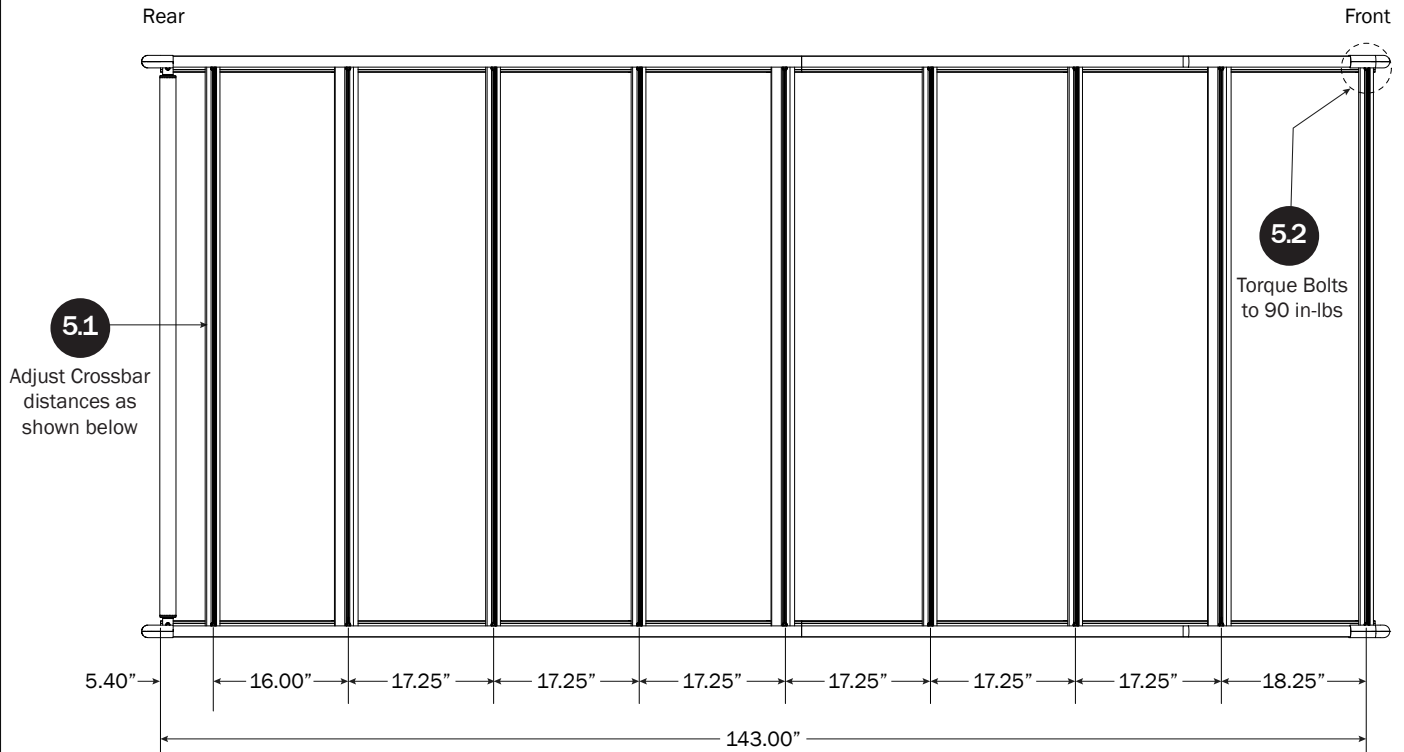

ROLLER ASSEMBLY

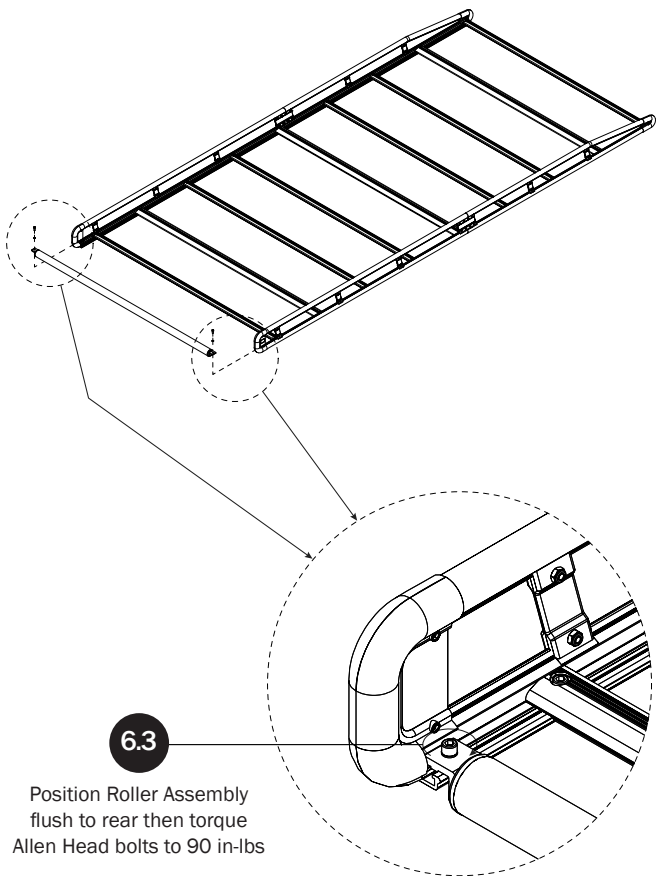
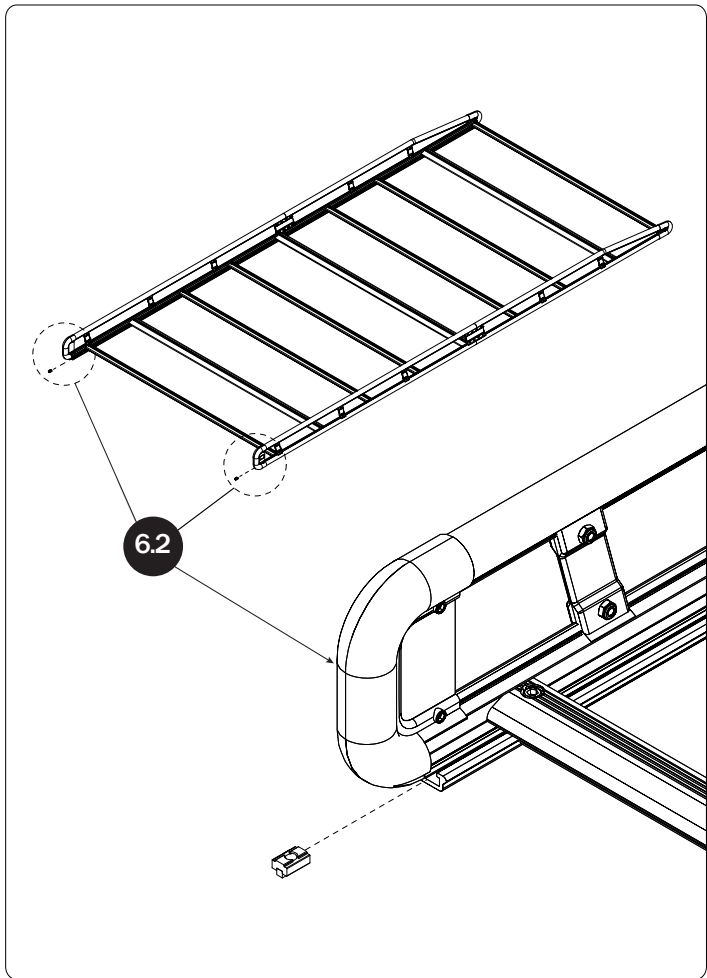
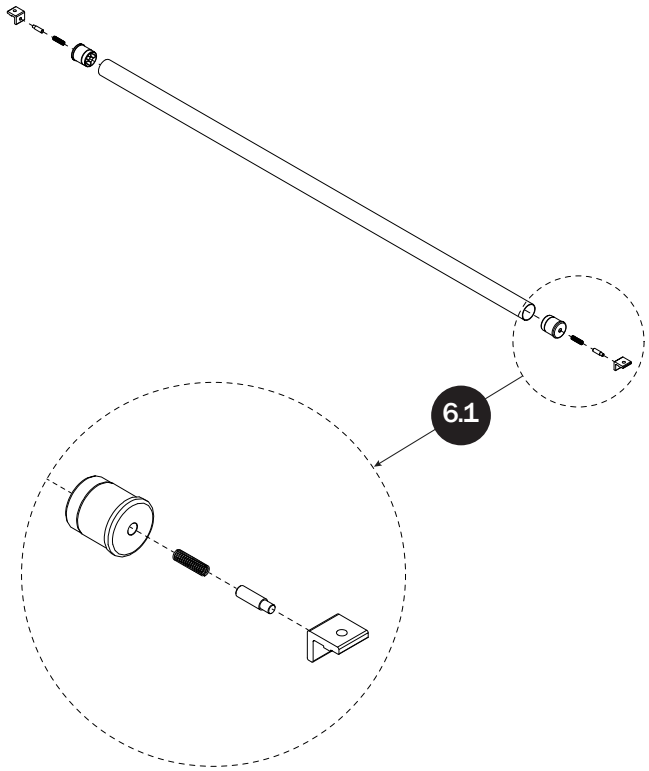

MOUNTING RACK TO CHANNELS

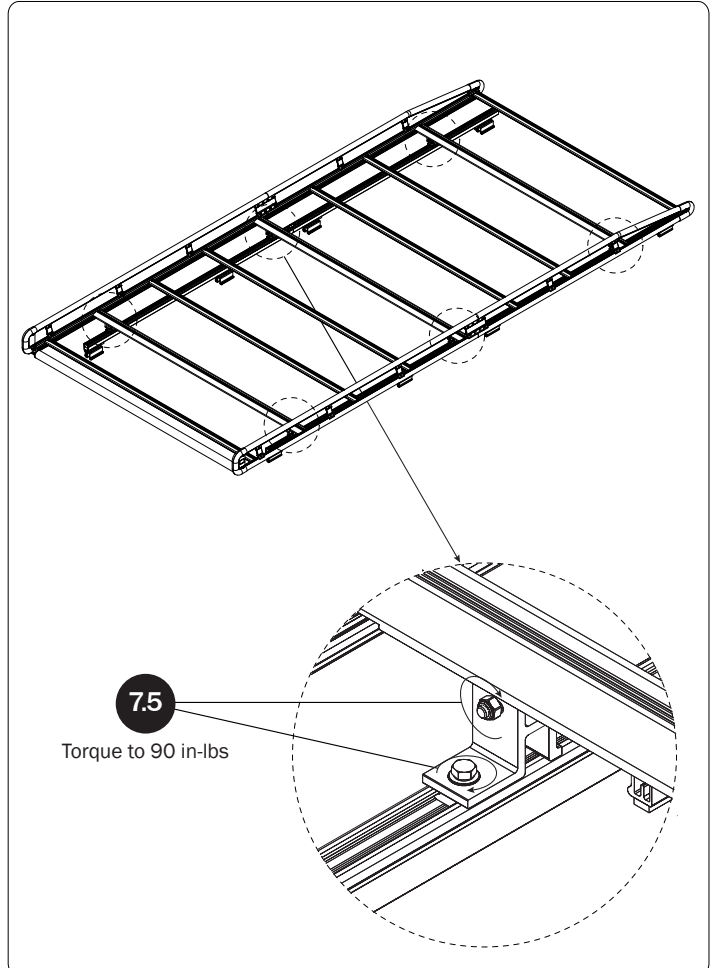
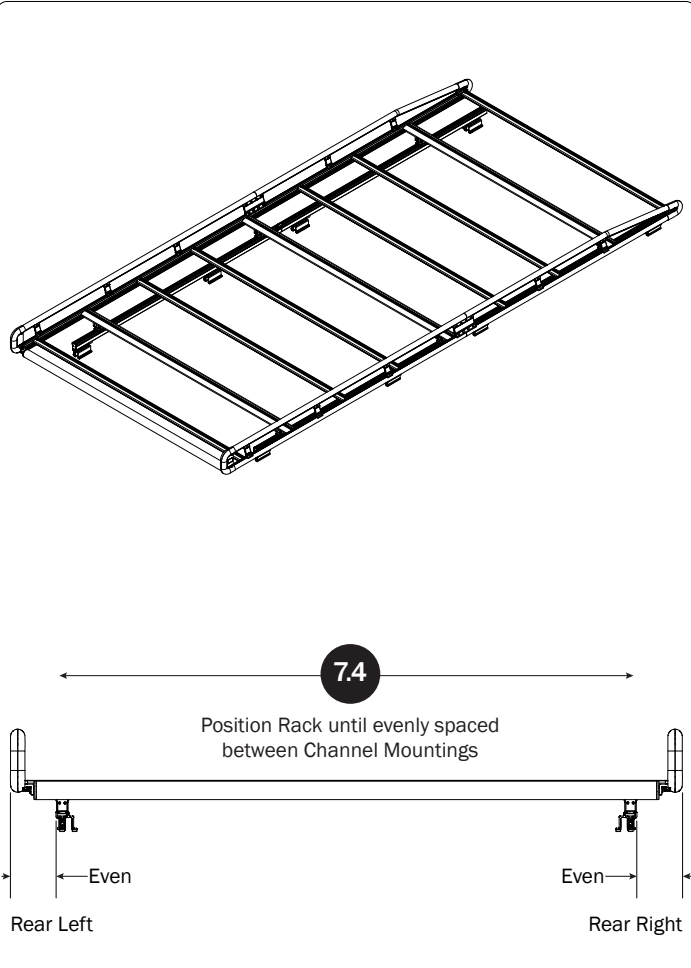
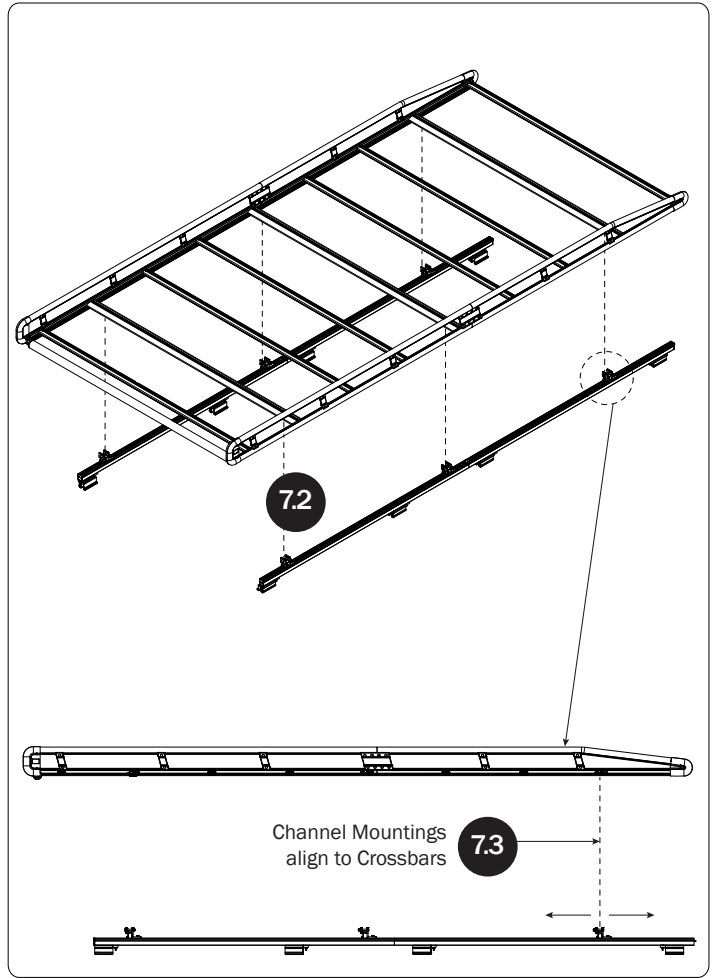
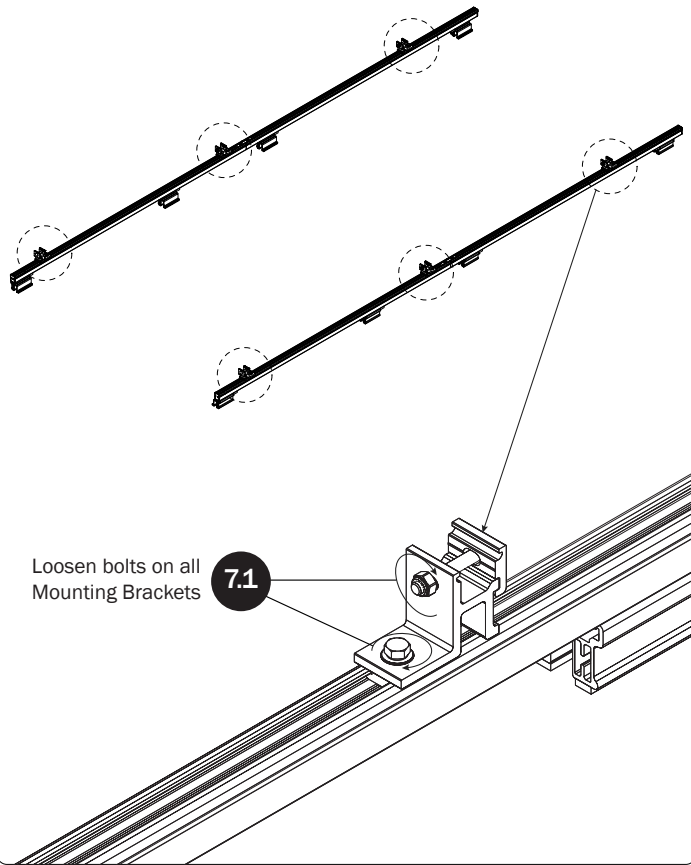

Page Intentionally Left Blank

