

INSTALLATION GUIDE

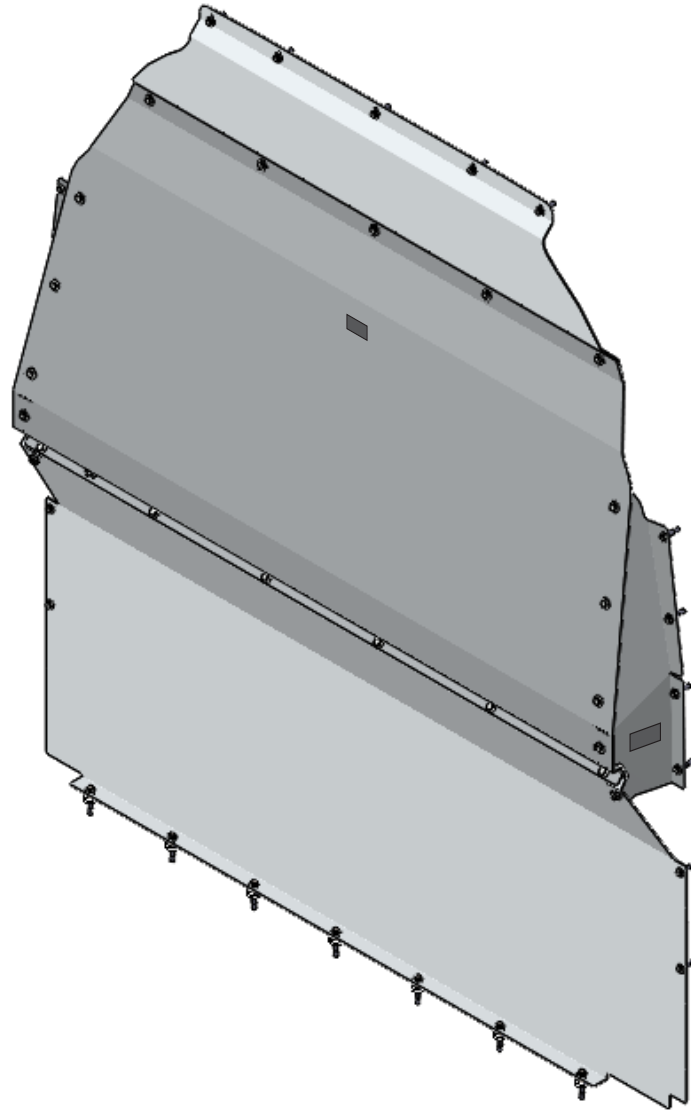

3010-DH CONTOURED PARTITION

Sprinter (Aluminum)



QUICK START GUIDE

Phase 1 - Assembly

<input type="checkbox"/> 1.1 Setup.....	3
<input type="checkbox"/> 1.1.1 Unpack components; compare with the bill of materials.....	3
<input type="checkbox"/> 1.1.2 Verify all parts are present.....	3
<input type="checkbox"/> 1.1.3 Identify the assembly and installation fastener bags.....	4
<input type="checkbox"/> 1.2 Partition assembly.....	5
<input type="checkbox"/> 1.2.1 Remove all the PVC from all the parts, then attach top panel to the upper panel.....	5
<input type="checkbox"/> 1.2.2 Attach the upper panel to the lower panel.....	5
<input type="checkbox"/> 1.2.3 Attach both wings to the upper and lower panels.....	6
<input type="checkbox"/> 1.2.4 Attach the edge trims along both sides of the upper and lower panels.....	6

Phase 2 - Installation

<input type="checkbox"/> 2.1 Tips on how to attach a plusnut.....	7
<input type="checkbox"/> 2.1.1 Attach plusnut using plusnut gun.....	7
<input type="checkbox"/> 2.1.2 Attach plusnut using Ranger plusnut tool.....	7
<input type="checkbox"/> 2.2 Vehicle preparation.....	8
<input type="checkbox"/> 2.2.1 Attaching plusnuts.....	8
<input type="checkbox"/> 2.3 Contoured partition installation.....	9
<input type="checkbox"/> 2.3.1 Attach the upper panel and lower panel to the van.....	9
<input type="checkbox"/> 2.3.2 Bolt both ends of the partition in the van.....	10
<input type="checkbox"/> 2.3.3 Apply the warning label on the upper panel.....	11

REQUIRED ITEMS

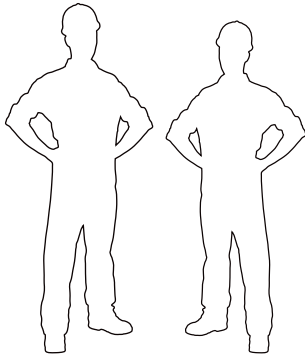

2
PERSONS

- Cordless Impact
- Cordless Drill
- Cutter
- Mallet
- Marker
- Plusnut Tool
- Tape Measure
- 3/8" Drill Bit
- 7/16" Socket
- 1/2" Socket
- 9/16" Wrench
- 1" Hole Saw

PHASE 1 – ASSEMBLY

1.1 SETUP

1.1.1 Unpack components; compare with the bill of materials.

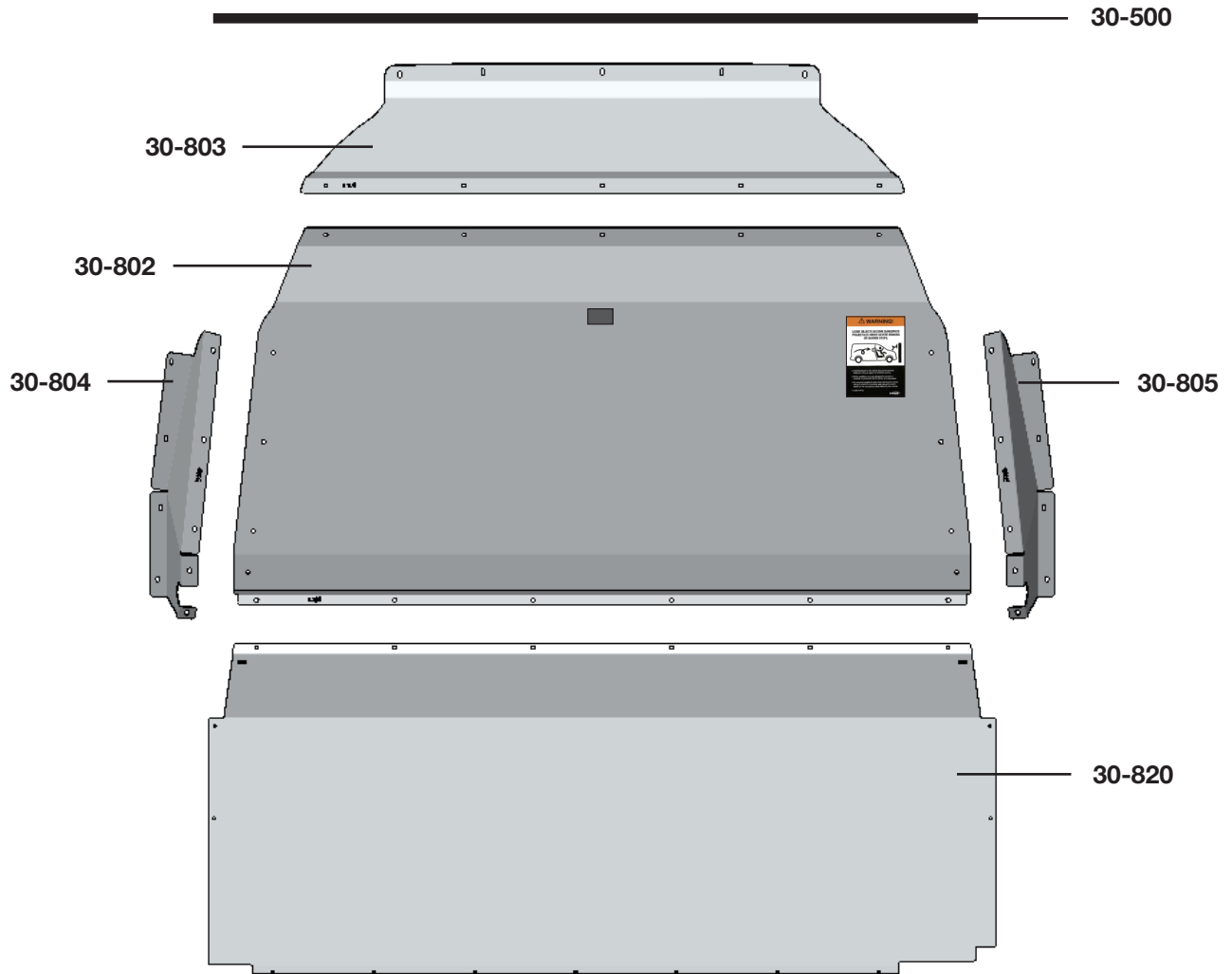

1.1.2 Verify all parts are present.



Item No.	Description	Qty.
30-500	Edge Trim (QTY in Inches)	92
30-802	Upper Panel	1
30-803	Top Panel	1
30-804	Driver Side Wing	1
30-805	Passenger Side Wing	1
30-820	Lower Panel	1
79-932	Bilingual Warning Label	1
94-3013	Assembly Fastener Bag	1
96-3008	Installation Fastener Bag	1

1.1.3 Identify the **Assembly** and **Installation** fastener bags.

Assembly Fastener Bag →

- 21x  # 90-204 Hex Bolt
5/16"-18 x 3/4"
GR-5 ZINC
- 21x  # 94-116 Serrated Nut
5/16"-18
ZINC
- 21x  # 98-116 Flat Washer
5/16", 7/8" OD
ZINC





Hardware Assembly





- 21x
-  #90-204 Hex Bolt 5/16" x 3/4"
 -  #98-116 Flat Washer
 -  #94-116 Serrated Nut

Installation Fastener Bag →

- 17x  # 90-114 Hex Bolt
1/4"-20 x 1"
GR-5 ZINC
- 7x  # 90-130 Hex Bolt
1/4"-20 x 2"
GR-5 ZINC
- 24x  # 94-130 Plusnut .250
- 24x  # 98-112 Flat Washer
1/4", 3/4" OD
ZINC
- 24x  # 98-118 Lock Washer
Regular 1/4"
ZINC
- 21x  # 98-157 Spacer
0.375" ID, x 1.0" OD x 0.25" L
NYLON

Hardware Assembly

- 17x
-  #90-114 Hex Bolt 1/4" x 1"
 -  #98-118 Lock Washer
 -  #98-112 Flat Washer
 -  #94-130 Plusnut .250

- 7x
-  #90-130 Hex Bolt 1/4" x 2"
 -  #98-118 Lock Washer
 -  #98-112 Flat Washer
 -  #98-157 Spacers (3)
 -  #94-130 Plusnut .250

PHASE 1 – ASSEMBLY

1.2 PARTITION ASSEMBLY

1.2.1 Remove all the PVC from all the parts, then attach top panel to the upper panel.

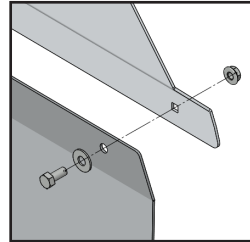
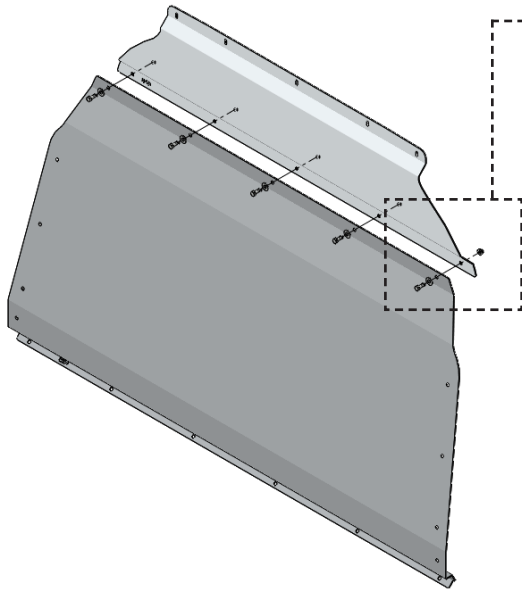



TOOLS

- Cordless Impact
- 1/2" Socket

HARDWARE USED

5x

-  #90-204 Hex Bolt 5/16" x 3/4"
-  #98-116 Flat Washer
-  #94-116 Serrated Nut

1.2.2 Attach the upper panel to the lower panel.

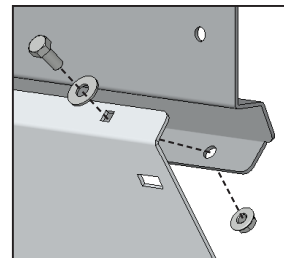
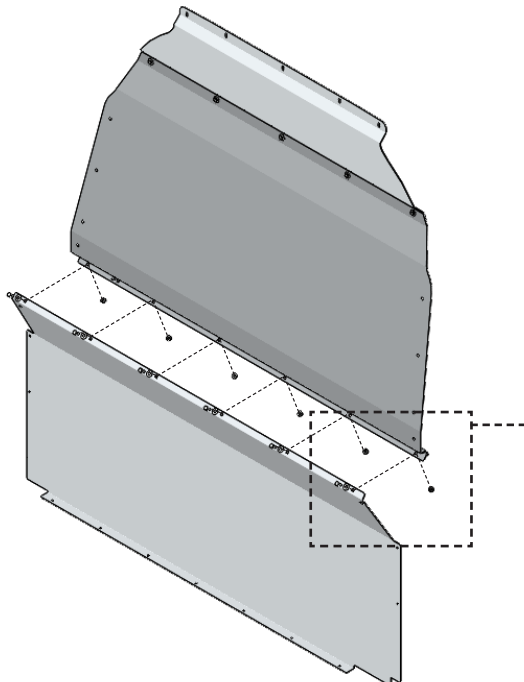



TOOLS

- Cordless Impact
- 1/2" Socket

HARDWARE USED

6x

-  #90-204 Hex Bolt 5/16" x 3/4"
-  #98-116 Flat Washer
-  #94-116 Serrated Nut

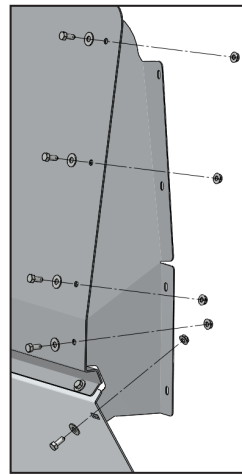
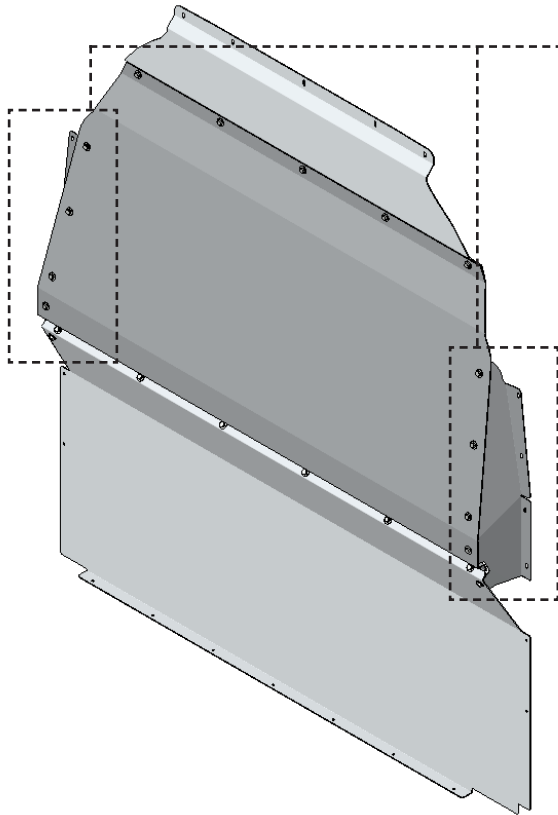

1.2.3 Attach both wings to the upper and lower panels.



- TOOLS**
- Cordless Impact
 - 1/2" Socket

HARDWARE USED

10x

-  #90-204 Hex Bolt 5/16" x 3/4"
-  #98-116 Flat Washer
-  #94-116 Serrated Nut

1.2.4 Attach the edge trims along both sides of the upper and lower panels.

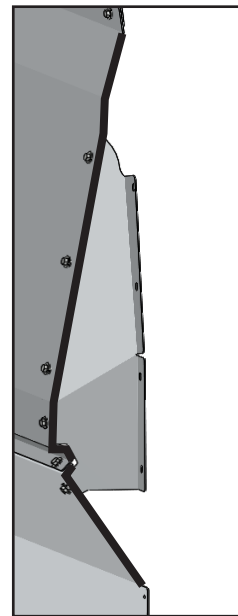
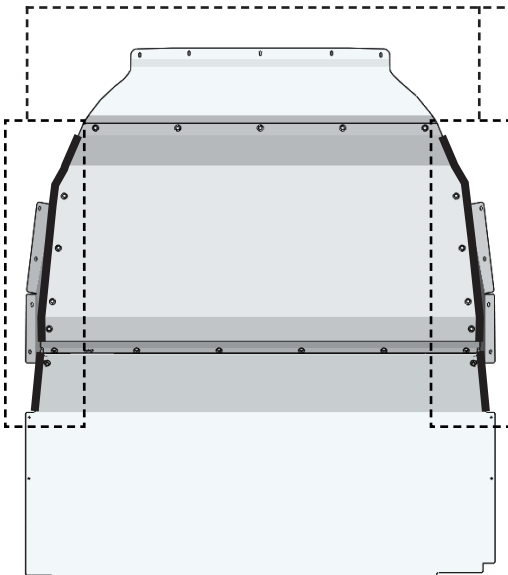

- TOOLS**
- Mallet
 - Cutter

PHASE 2 – INSTALLATION

2.1 TIPS ON HOW TO ATTACH A PLUSNUT

2.1.1 Attach the plusnut using the plusnut gun.

TIPS: Put the plusnut on the plusnut gun, then attach the plusnut in the hole by turning the gun forward until the plusnut locks, then remove the gun by turning in reverse.

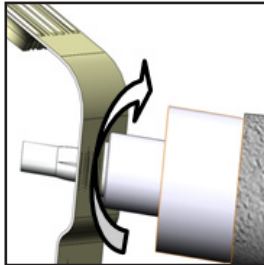

FORWARD

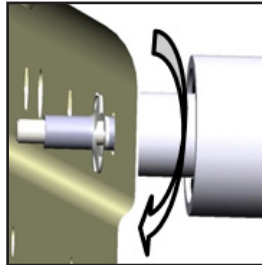

REVERSE

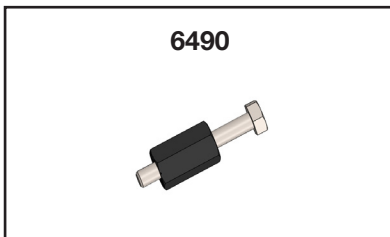

2.1.2 Attach the plusnut using the 6490 plusnut tool.

NOTE: The hardware used for the 6490 plusnut tool is not included in the fastener bag. The 6490 plusnut tool can be ordered separately upon demand at no charge.



6490

HARDWARE USED

-  Flat washer 1/4"
-  Flat washer 1/4" BS x 3/4" OD

TOOLS

- Cordless Impact
- 7/16" Socket
- 9/16" Wrench

TIPS STEP 1:

Assemble the 6490 plusnut tool with the hardware needed, plusnut and the 9/16" wrench as shown.



TIPS STEP 2:

Attach the plusnut in the hole by turning the bolt forward using an impact with a 7/16" socket until the plusnut locks, then remove the bolt by turning the impact in reverse.

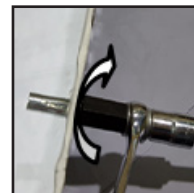

FORWARD



REVERSE

PHASE 2 – INSTALLATION

2.2 VEHICLE PREPARATION

2.2.1 Attaching plusnuts.

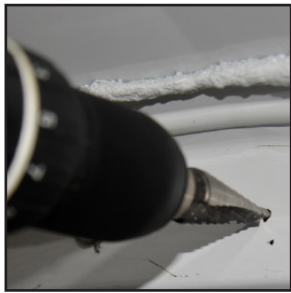
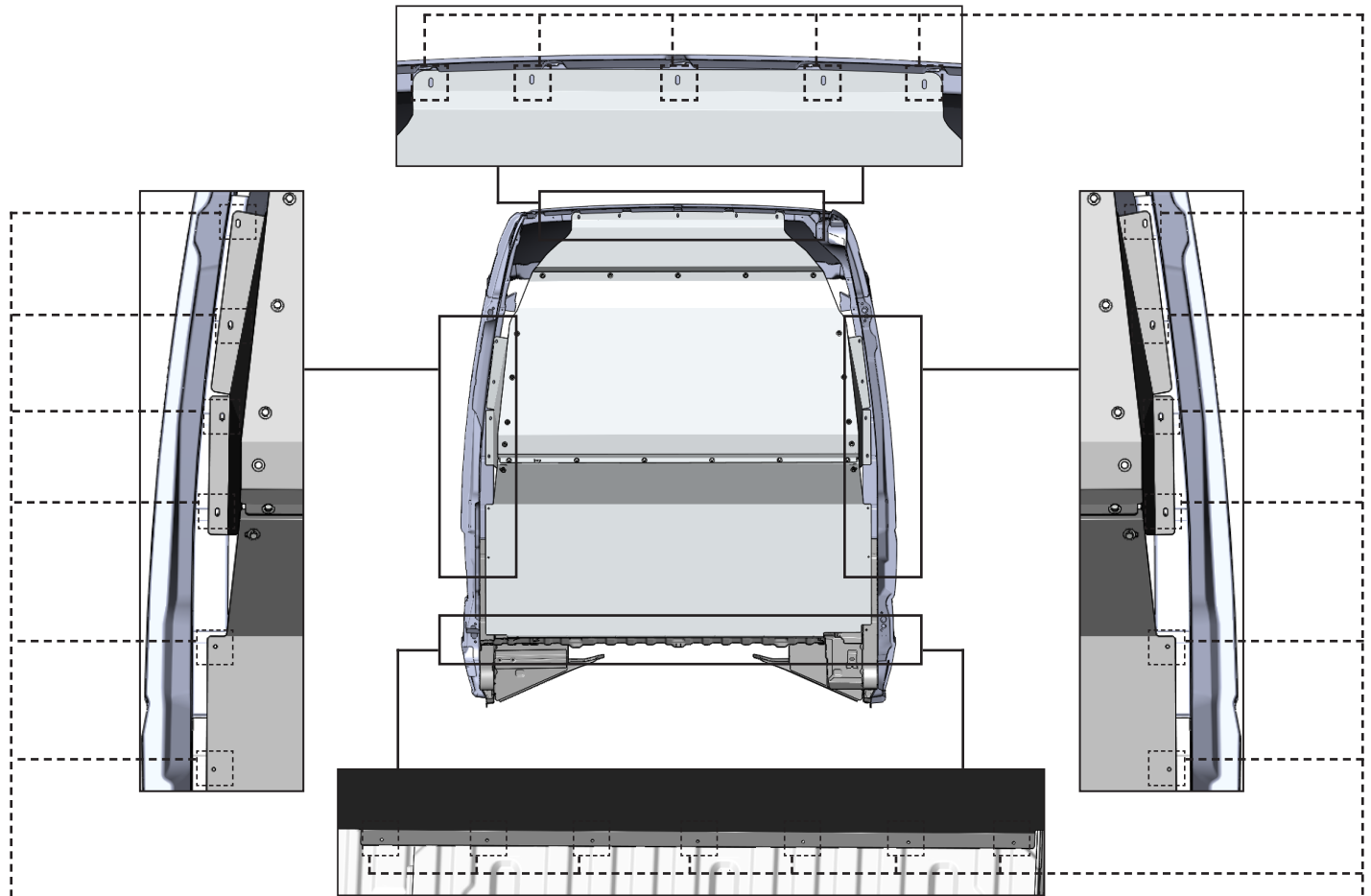

Check all holes of the partition if they are aligned in the holes of the van, then enlarge all the holes in the van that align with the holes of the partition using 3/8" drill bit or step drill.

NOTE: • Make new holes in the van if the holes are not aligned with the hole of the partition.

• If the van has a rubber or wood floor use a 1" hole saw to drill the floor and use a 3/8" drill bit or step drill to make a hole in the van (make sure the holes are aligned with the holes of the partition.)

TOOLS

Cordless Drill 3/8" Drill Bit or Step Drill 1" Hole Saw



Attach a plusnuts in the holes.

TOOLS

Plusnut Tool

HARDWARE USED

24x



94-130
Plusnut .250

PHASE 2 – INSTALLATION

2.3 CONTOURED PARTITION INSTALLATION

2.3.1 Attach the upper panel and lower panel to the van.

NOTE: Use spacers to make the floor level, if you have a rubber or wood floor use 2 to 3 spacers to make the floor level.

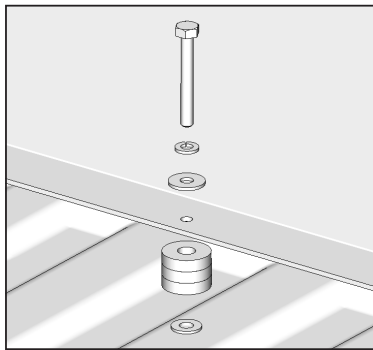
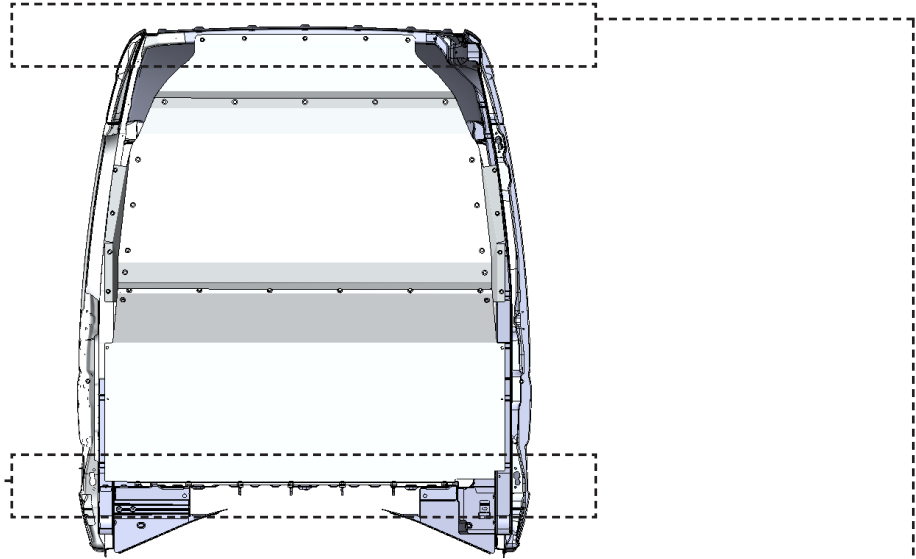

TOOLS

- Cordless Impact
- 7/16" Socket

HARDWARE USED

7x

-  #90-130 Hex Bolt 1/4" x 2"
-  #98-118 Lock Washer
-  #98-112 Flat Washer
-  #98-157 Spacers (3)

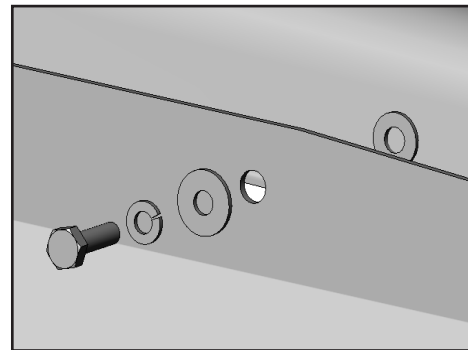

TOOLS

- Cordless Impact
- 7/16" Socket

HARDWARE USED

5x

-  #90-114 Hex Bolt 1/4" x 1"
-  #98-118 Lock Washer
-  #98-112 Flat Washer

2.3.2 Bolt both sides of the partition in the van.

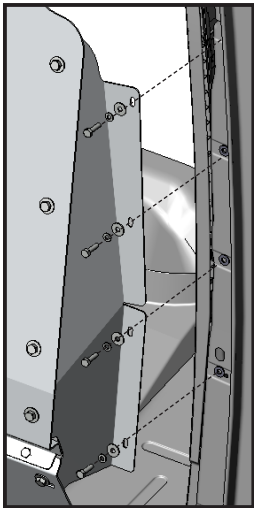
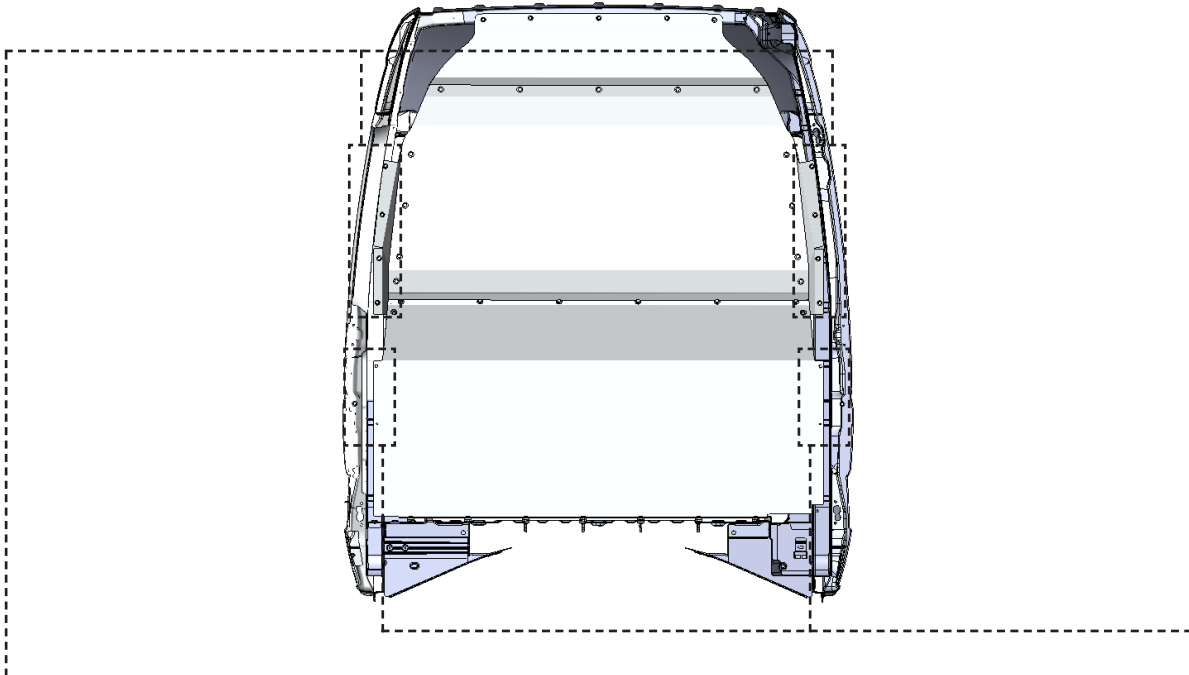

TOOLS

- Cordless Impact
- 7/16" Socket

HARDWARE USED

8x

-  #90-114 Hex Bolt 1/4" x 1"
-  #98-118 Lock Washer
-  #98-112 Flat Washer

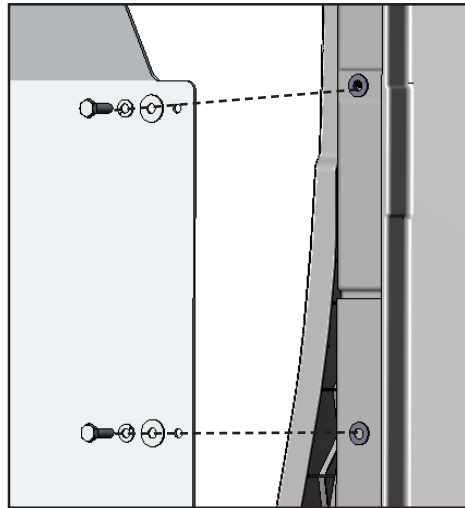



TOOLS

- Cordless Impact
- 7/16" Socket

HARDWARE USED

4x

-  #90-114 Hex Bolt 1/4" x 1"
-  #98-118 Lock Washer
-  #98-112 Flat Washer

2.3.3 Apply the warning label on the upper panel.

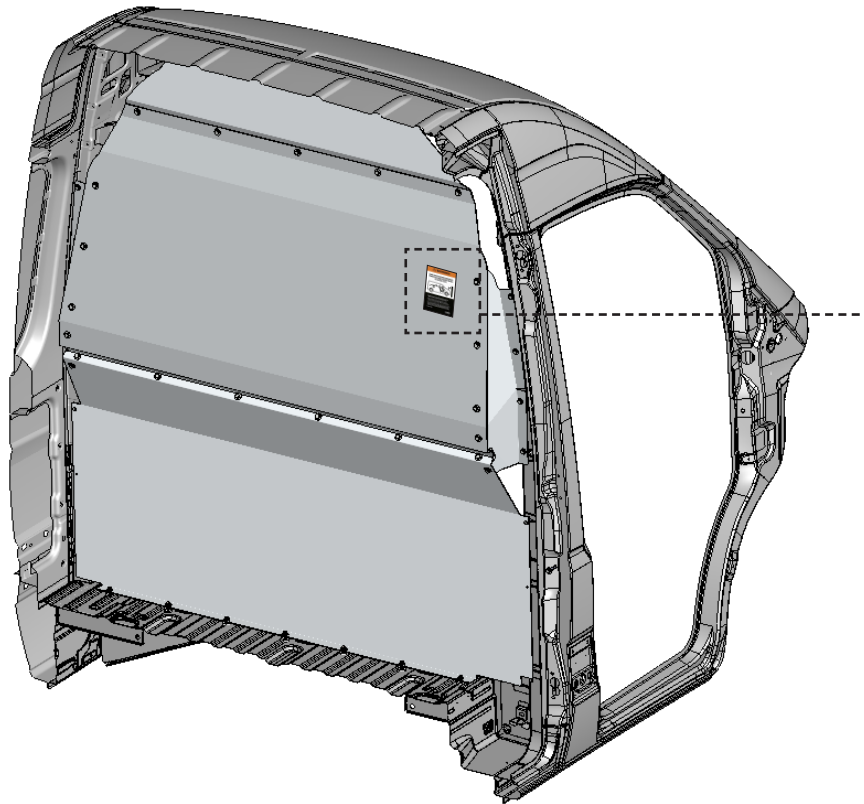

NOTE: English warning label is already attached on the passenger side panel.

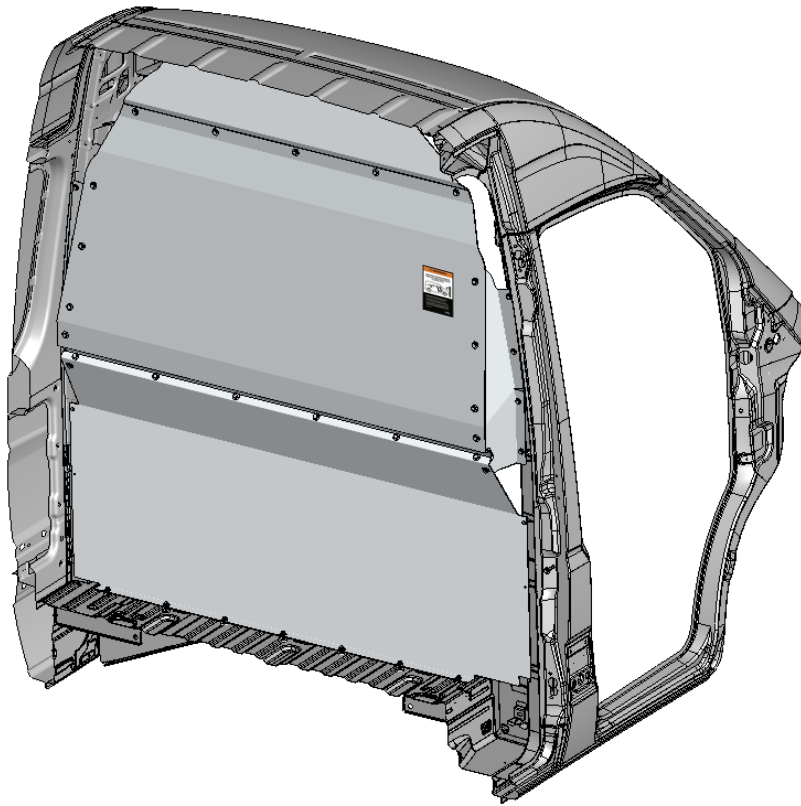

**“Congratulations, you have successfully installed your
Contoured Partition!”**

Thank you for doing business with us.”

