

# INSTALLATION GUIDE

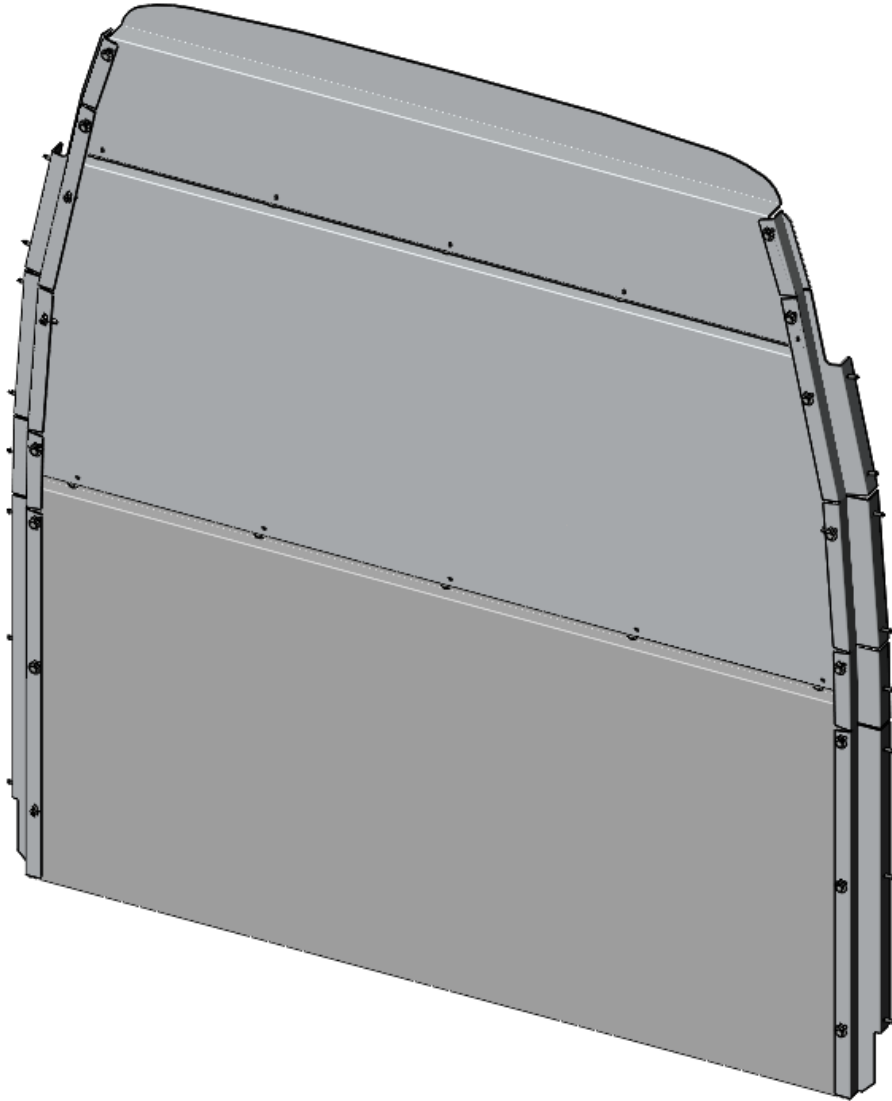

## 3015-DH STRAIGHT PARTITION

Sprinter ( Mid Position, Aluminum )



# QUICK START GUIDE

## Phase 1 - Assembly

- 1.1 Setup..... 3
- 1.1.1 Unpack components; compare with the bill of materials..... 3
- 1.1.2 Verify all parts are present..... 3
- 1.1.3 Identify the assembly and installation fastener bags..... 4
- 1.2 Partition assembly..... 5
- 1.2.1 Remove all the PVC from all the parts, then attach top panel to the upper panel..... 5
- 1.2.2 Attach the upper panel to the lower panel..... 5
- 1.2.3 Attach both wings to the top, upper and lower panels..... 6
- 1.2.4 Attach the edge trims on top and bottom of the driver and passenger side wings..... 6

## Phase 2 - Installation

- 2.1 Tips on how to attach a plusnut..... 7
- 2.1.1 Attach plusnut using plusnut gun..... 7
- 2.1.2 Attach plusnut using Ranger plusnut tool..... 7
- 2.2 Vehicle preparation..... 8
- 2.2.1 Holes preparation..... 8
- 2.3 Straight partition installation..... 9
- 2.3.1 Bolt the lower panel to the van..... 9
- 2.3.2 Bolt both ends of the partition in the van..... 10
- 2.3.3 Apply the warning label on the upper panel..... 11

# REQUIRED ITEMS

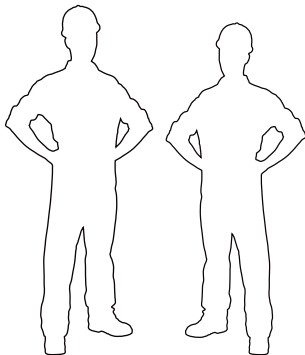

**2  
PERSONS**

- Cordless Impact
- Cordless Drill
- Cutter
- Mallet
- Marker
- Plusnut Tool
- Tape Measure
- 3/8" Drill Bit
- 7/16" Socket
- 1/2" Socket
- 9/16" Wrench
- 1" Hole Saw

# PHASE 1 – ASSEMBLY

## 1.1 SETUP

1.1.1 Unpack components; compare with the bill of materials.

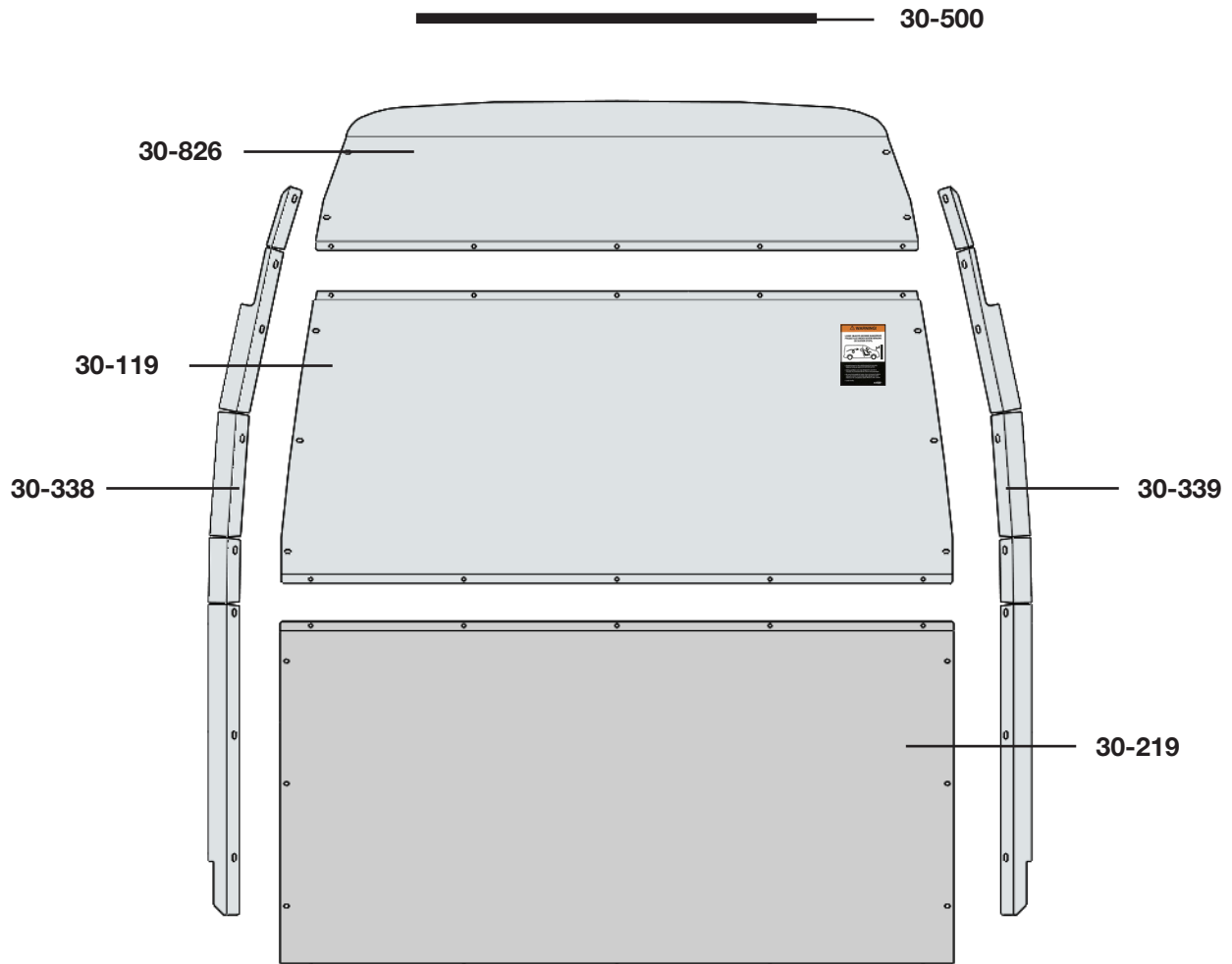

1.1.2 Verify all parts are present.

Item No.	Description	Qty.
30-500	Edge Trim ( QTY in Inches )	55
30-119	Upper Panel	1
30-219	Lower Panel	1
30-338	Driver Side Wing	1
30-339	Passenger Side Wing	1
30-826	Top Panel	1
79-932	Warning Label ( Bilingual )	1
94-3033	Assembly Fastener Bag	1
96-3020	Installation Fastener Bag	1



1.1.3 Identify the **Assembly** and **Installation** fastener bags.

**Assembly Fastener Bag** →

- 26x**  **# 90-204** Hex Bolt  
5/16"-18 x 3/4"  
GR-5 ZINC
- 26x**  **# 94-116** Serrated Nut  
5/16"-18  
ZINC
- 26x**  **# 98-116** Flat Washer  
5/16", 7/8" OD  
ZINC

**Hardware Assembly**

**26x**

-  #90-204 Hex Bolt 5/16" x 3/4"
  -  #98-116 Flat Washer
  -  #94-116 Serrated Nut

**Installation Fastener Bag** →





- 16x**  **# 90-114** Hex Bolt  
1/4"-20 x 1"  
GR-5 ZINC
- 5x**  **# 90-130** Hex Bolt  
1/4"-20 x 2"  
GR-5 ZINC
- 21x**  **# 94-130** Plusnut .250
- 21x**  **# 98-112** Flat Washer  
1/4", 3/4" OD  
ZINC
- 21x**  **# 98-118** Lock Washer  
Regular 1/4"  
ZINC
- 15x**  **# 98-157** Spacer  
0.375" ID, x 1.0" OD x 0.25" L  
NYLON

**Hardware Assembly**

**16x**

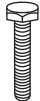
-  #90-114 Hex Bolt 1/4" x 1"
  -  #98-118 Lock Washer
  -  #98-112 Flat Washer
  -  #94-130 Plusnut .250

**5x**

-  #90-130 Hex Bolt 1/4" x 2"
  -  #98-118 Lock Washer
  -  #98-112 Flat Washer
  -  #98-157 Spacers ( 3 )
  -  #94-130 Plusnut .250

# PHASE 1 – ASSEMBLY

## 1.2 PARTITION ASSEMBLY

1.2.1 Remove all the PVC from all the parts, then attach top panel to the upper panel.

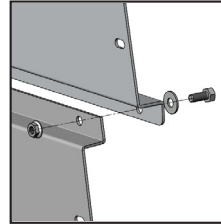
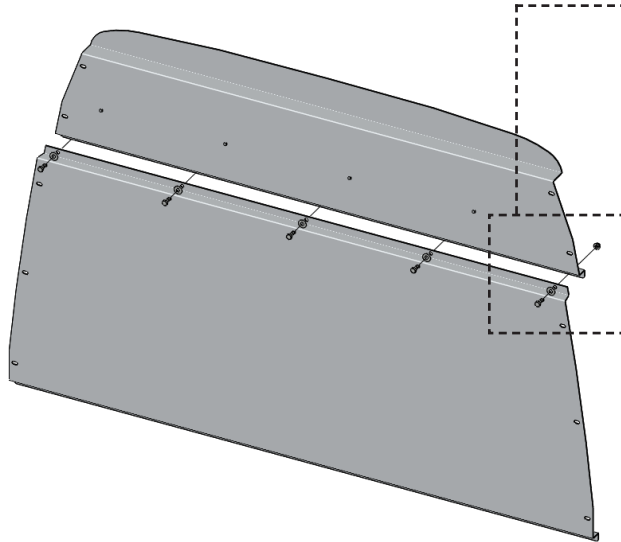



### TOOLS

- Cordless Impact
- 1/2" Socket

### HARDWARE USED

5x

-  #90-204 Hex Bolt 5/16" x 3/4"
-  #98-116 Flat Washer
-  #94-116 Serrated Nut

1.2.2 Attach the upper panel to the lower panel.

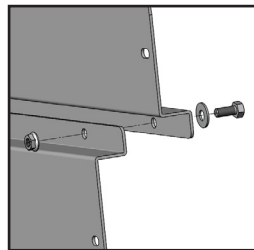
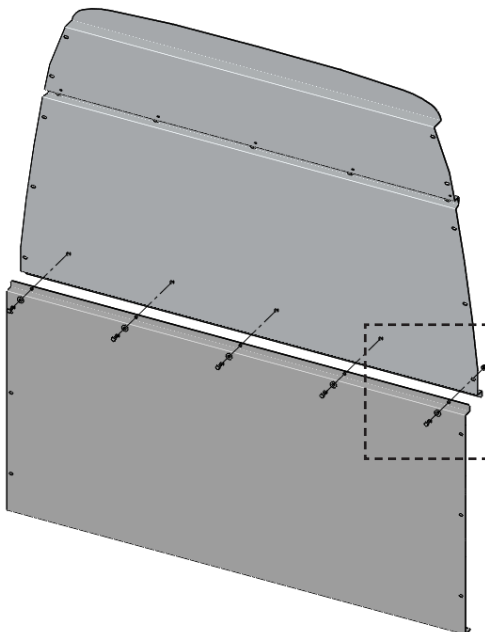



### TOOLS

- Cordless Impact
- 1/2" Socket

### HARDWARE USED

5x

-  #90-204 Hex Bolt 5/16" x 3/4"
-  #98-116 Flat Washer
-  #94-116 Serrated Nut

**1.2.3** Attach both wings to the top, upper and lower panels.

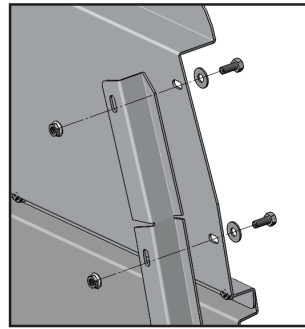
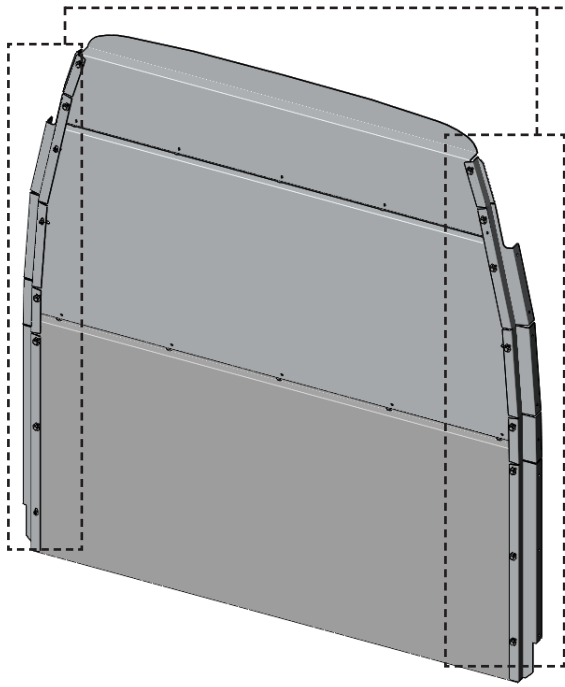



**TOOLS**

- Cordless Impact
- 1/2" Socket

**HARDWARE USED**

**16x**

-  #90-204 Hex Bolt 5/16" x 3/4"
-  #98-116 Flat Washer
-  #94-116 Serrated Nut

**1.2.4** Attach the edge trims on top and bottom of the driver and passenger side wings.

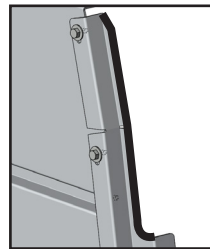
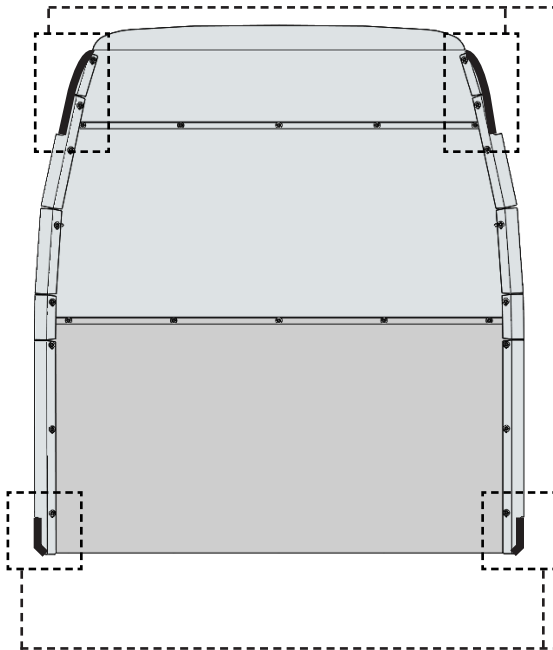

**TOOLS**

- Mallet
- Cutter

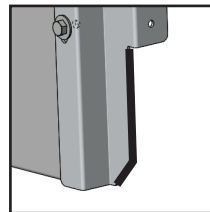

**TOOLS**

- Mallet
- Cutter

# PHASE 2 – INSTALLATION

## 2.1 TIPS ON HOW TO ATTACH A PLUSNUT

2.1.1 Attach the plusnut using the plusnut gun.

**TIPS:** Put the plusnut on the plusnut gun, then attach the plusnut in the hole by turning the gun forward until the plusnut locks, then remove the gun by turning in reverse.

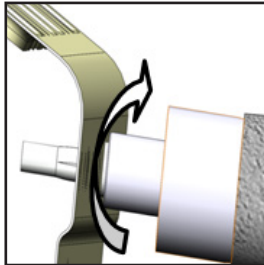

**FORWARD**

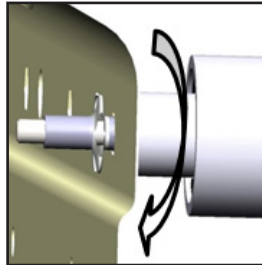

**REVERSE**

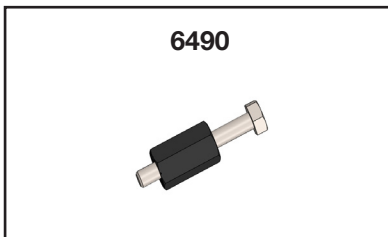

2.1.2 Attach the plusnut using the 6490 plusnut tool.

**NOTE:** The hardware used for the 6490 plusnut tool is not included in the fastener bag. The 6490 plusnut tool can be ordered separately upon demand at no charge.



**6490**

### HARDWARE USED

-  Flat washer 1/4"
-  Flat washer 1/4" BS x 3/4" OD

### TOOLS

- Cordless Impact
- 7/16" Socket
- 9/16" Wrench

### TIPS STEP 1:

Assemble the 6490 plusnut tool with the hardware needed, plusnut and the 9/16" wrench as shown.



### TIPS STEP 2:

Attach the plusnut in the hole by turning the bolt forward using an impact with a 7/16" socket until the plusnut locks, then remove the bolt by turning the impact in reverse.

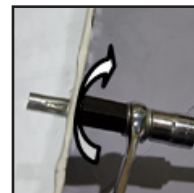

**FORWARD**



**REVERSE**

# PHASE 2 – INSTALLATION

## 2.2 VEHICLE PREPARATION

### 2.2.1 Holes Preparation.

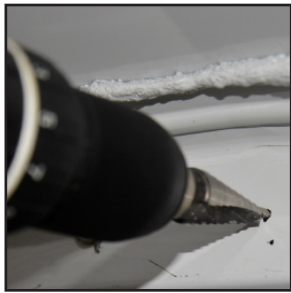
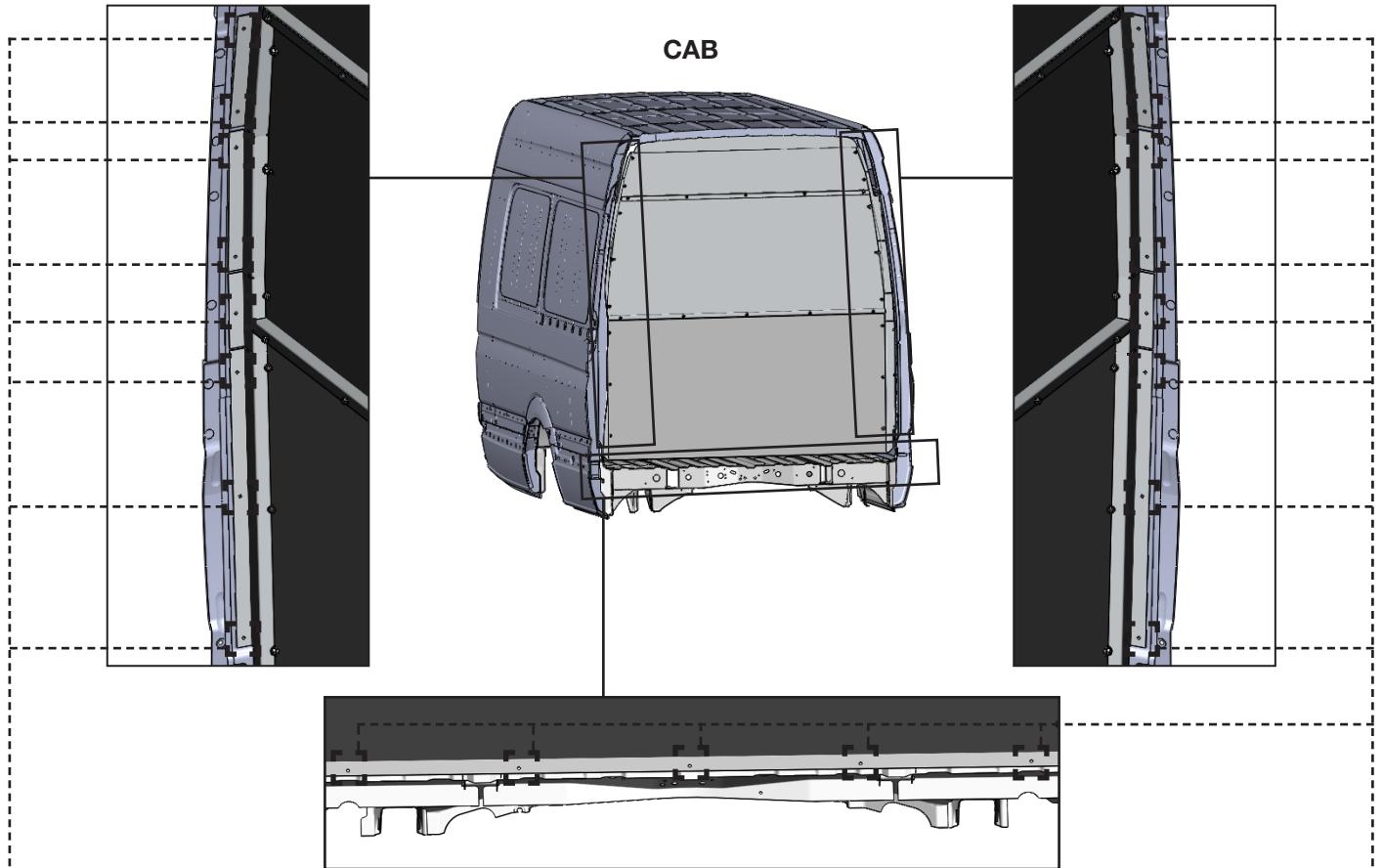

Stand the partition up forward of the center pillar, then, through the holes in the partition, mark the 21 drill holes. After removing the partition, drill 3/8" holes with a step drill.

**NOTE:** • If the van has a rubber or wood floor use a 1" hole saw to drill the floor and use a 3/8" drill bit or step drill to make a hole in the van (make sure the holes are aligned with the holes of the partition.)

#### TOOLS

- Cordless Drill
- 3/8" Drill Bit or Step Drill
- 1" Hole Saw



Attach plusnuts in the holes.

#### TOOLS

- Plusnut Tool

#### HARDWARE USED

**21x**



# 94-130  
Plusnut .250



# PHASE 2 – INSTALLATION

## 2.3 STRAIGHT PARTITION INSTALLATION

2.3.1 Bolt the lower panel to the van.

**NOTE:** Use spacers to make the floor level, if you have a rubber or wood floor use 2 or 3 spacers to make the floor level.

CAB

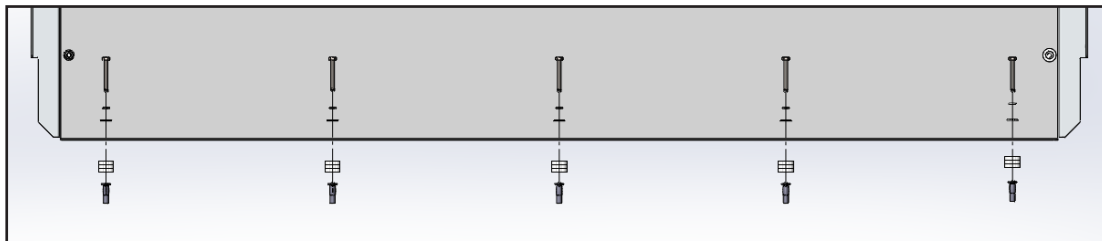
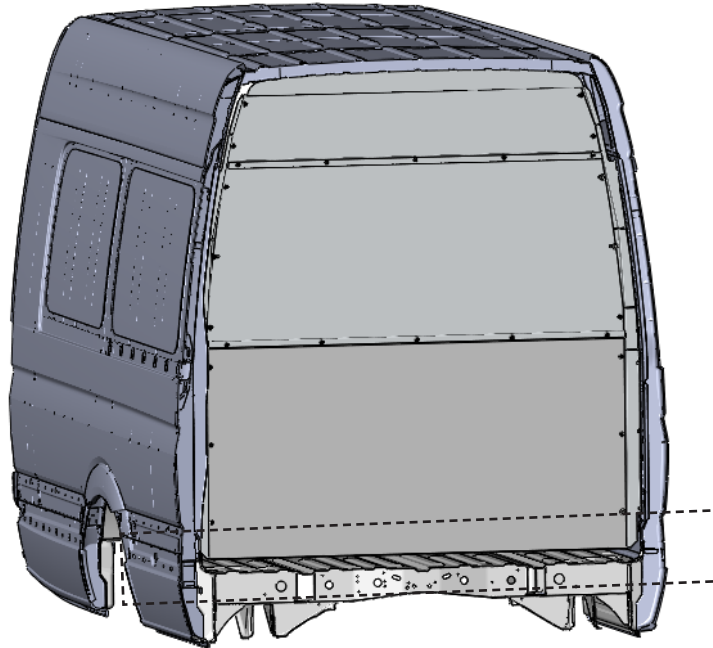

### TOOLS

- Cordless Impact
- 7/16" Socket

### HARDWARE USED

5x



#90-130 Hex Bolt 1/4" x 2"

#98-118 Lock Washer

#98-112 Flat Washer

#98-157 Spacers (3)

2.3.2 Bolt both sides of the partition in the van.

CAB

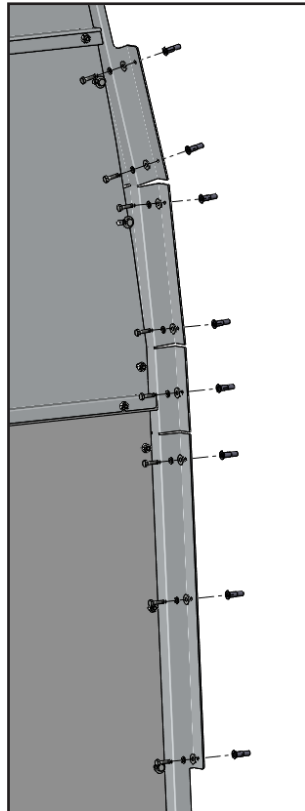
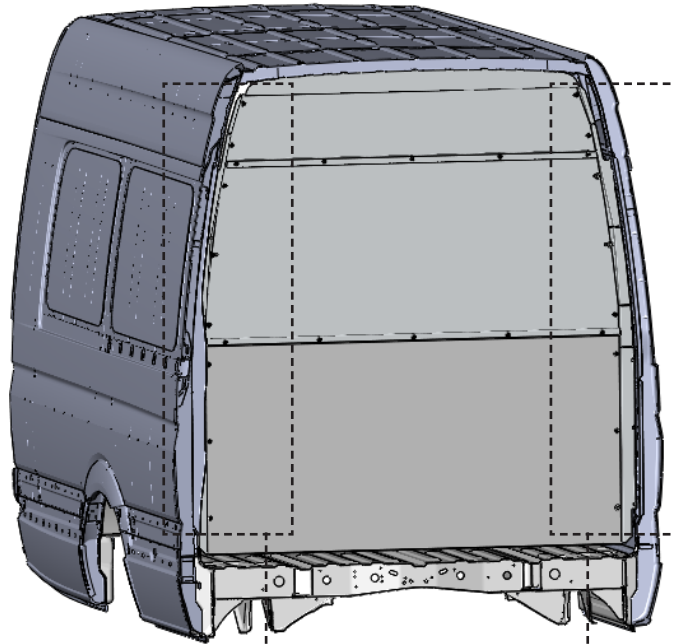



**TOOLS**

- Cordless Impact
- 7/16" Socket

**HARDWARE USED**

**16x**

- |   |                            |
|---|----------------------------|
|  | #90-114 Hex Bolt 1/4" x 1" |
|  | #98-118 Lock Washer        |
|  | #98-112 Flat Washer        |

2.3.3 Apply the warning label on the upper panel.

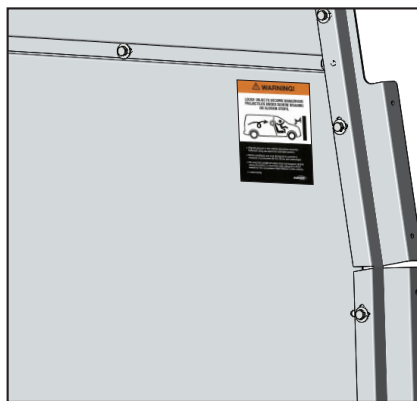
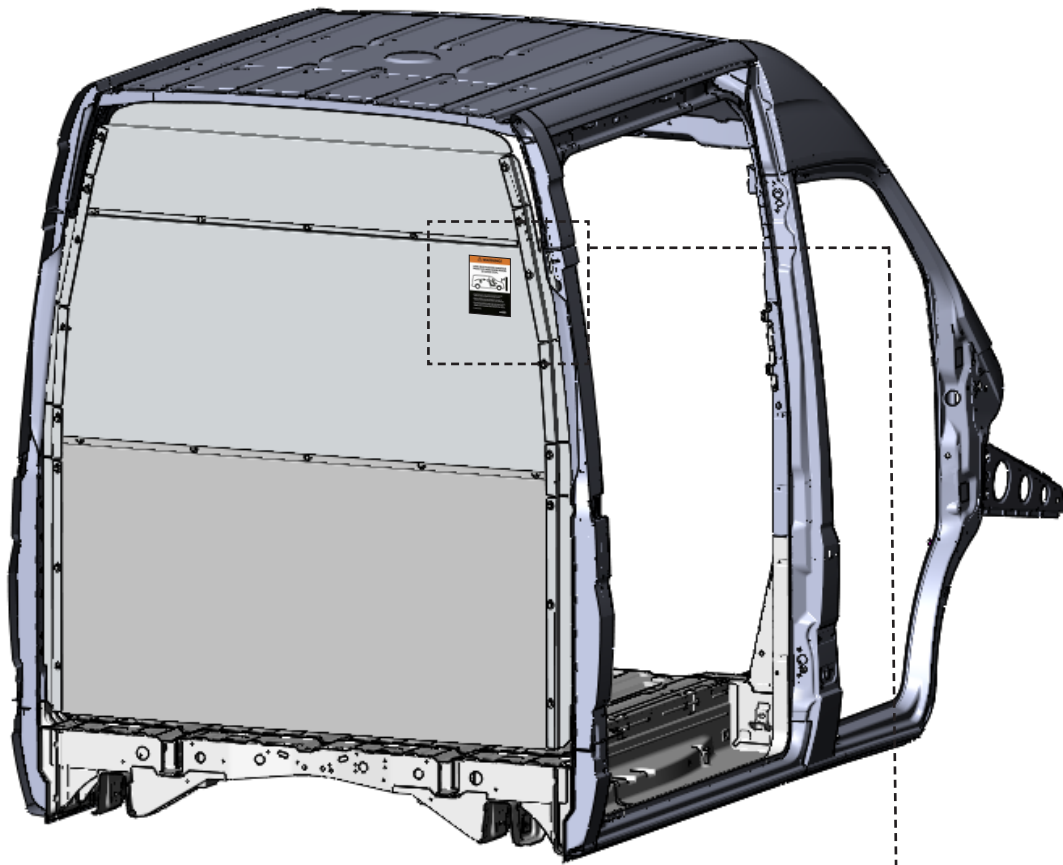

**NOTE:** English warning label is already attached on the passenger side panel.

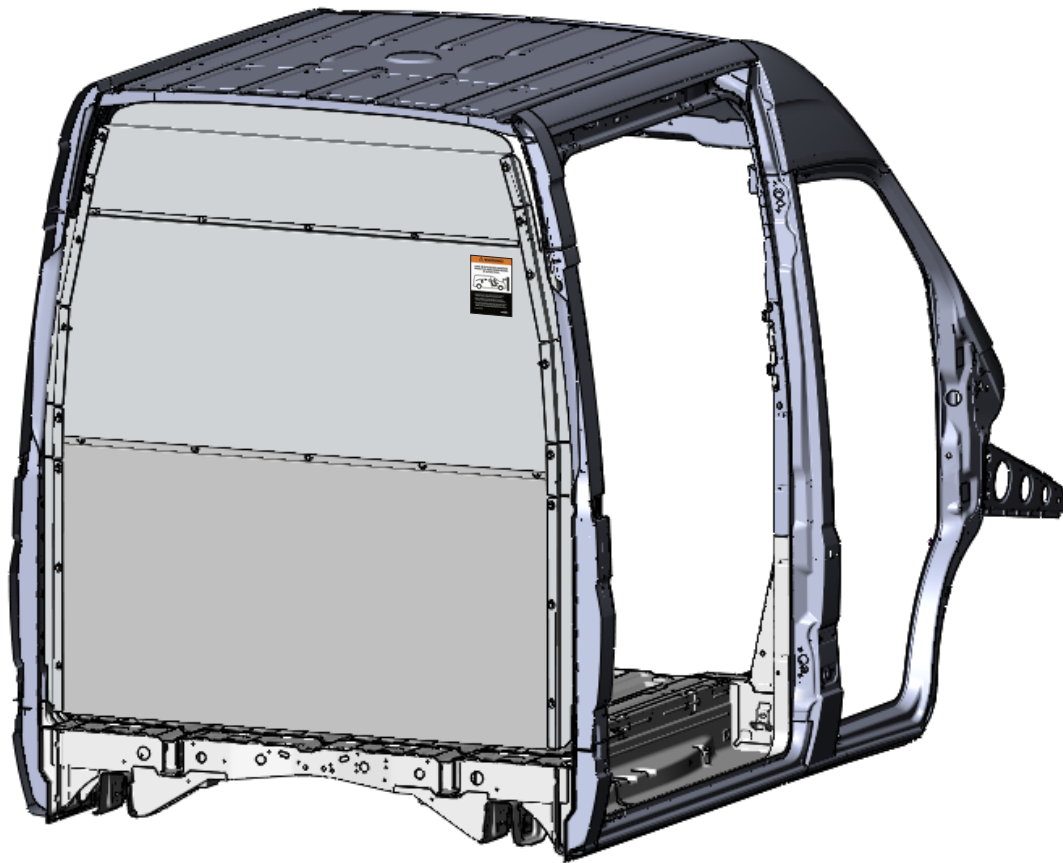

**“Congratulations, you have successfully installed your  
Straight Partition!”**

**Thank you for doing business with us.”**

