

INSTALLATION GUIDE

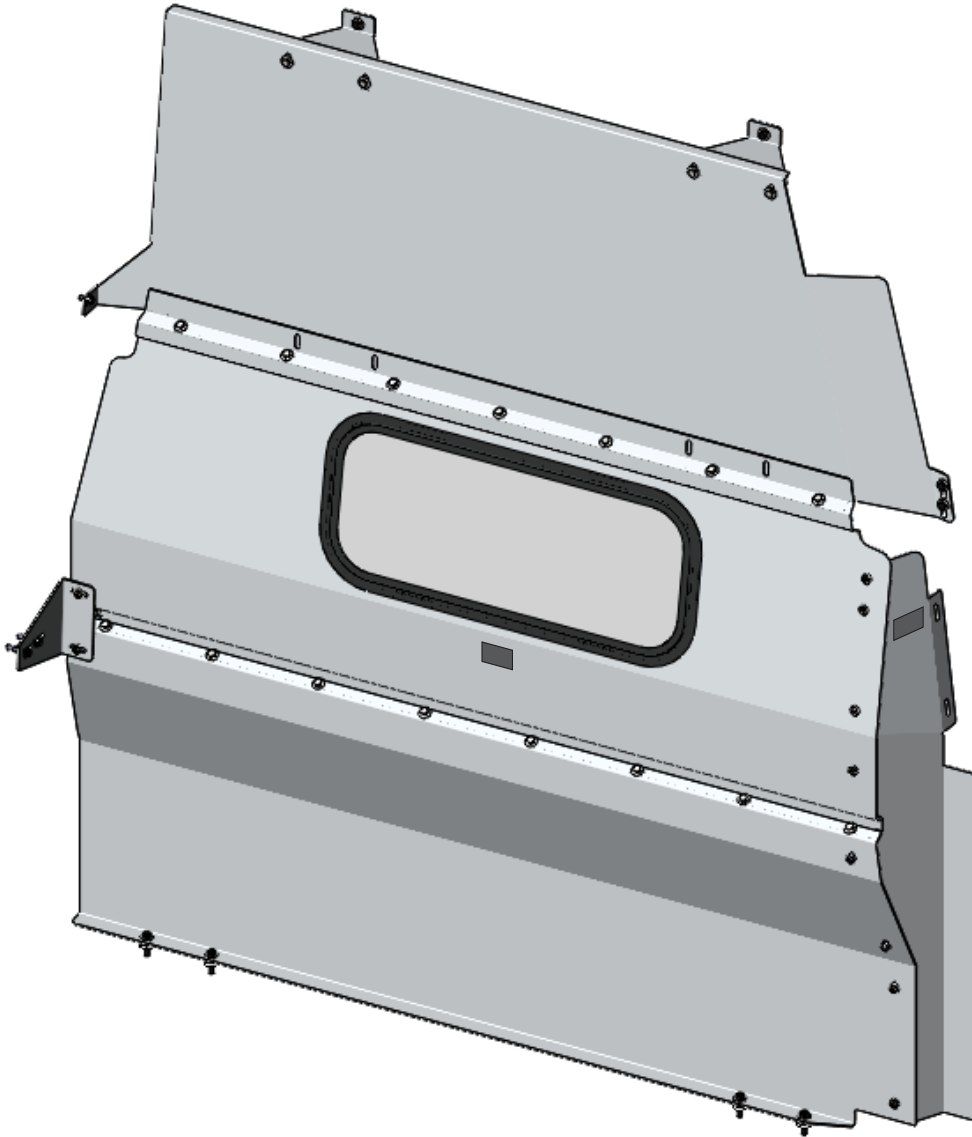

3020-NH CONTOURED PARTITION

Nissan NV (Tempered Glass Window, Aluminum)



QUICK START GUIDE

Phase 1 - Assembly

- 1.1 Setup..... 3
 - 1.1.1 Unpack components; compare with the bill of materials..... 3
 - 1.1.2 Verify all parts are present..... 3
 - 1.1.3 Identify the assembly and installation fastener bags..... 4
- 1.2 Partition assembly..... 5
 - 1.2.1 Remove all the PVC from all the parts, then attach upper panel to the lower panel..... 5
 - 1.2.2 Attach both wings to the upper and lower panels..... 6
 - 1.2.3 Attach the edge trims along both sides of the upper and lower panels..... 7

Phase 2 - Installation

- 2.1 Tips on how to attach a plusnut..... 8
 - 2.1.1 Attach plusnut using plusnut gun..... 8
 - 2.1.2 Attach plusnut using Ranger plusnut tool..... 8
- 2.2 Vehicle preparation..... 9
 - 2.2.1 Remove the grab handle, the cap on the B-pillar and and the 2 D-rings in the van..... 9
- 2.3 Contoured partition installation..... 10
 - 2.3.1 Attach the 2 ceiling brackets in the van..... 10
 - 2.3.2 Attach the top panel to the ceiling brackets, then bolt
the both sides of the top panel in the van..... 11
 - 2.3.3 Lift the assembled partition into the van, then attach plusnuts in the van..... 12
 - 2.3.4 Attach the upper panel to the top panel..... 13
 - 2.3.5 Bolt the lower panel in the van..... 13
 - 2.3.6 Bolt both wings of the partition in the van..... 14
 - 2.3.7 Apply the warning label on the passenger side panel and re-install
grab handle on the upper panel of the partition..... 15

REQUIRED ITEMS

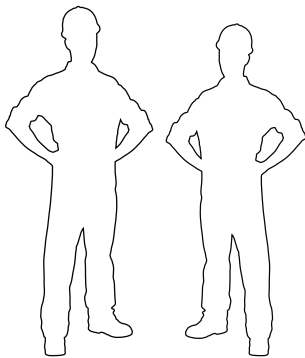

2
PERSONS

- Cordless Impact
- Cordless Drill
- Cutter
- Mallet
- Marker
- Plusnut Tool
- Tape Measure
- 3/8" Drill Bit
- 7/16" Socket
- 1/2" Socket
- 9/16" Wrench
- 13mm Socket

PHASE 1 – ASSEMBLY

1.1 SETUP

1.1.1 Unpack components; compare with the bill of materials.

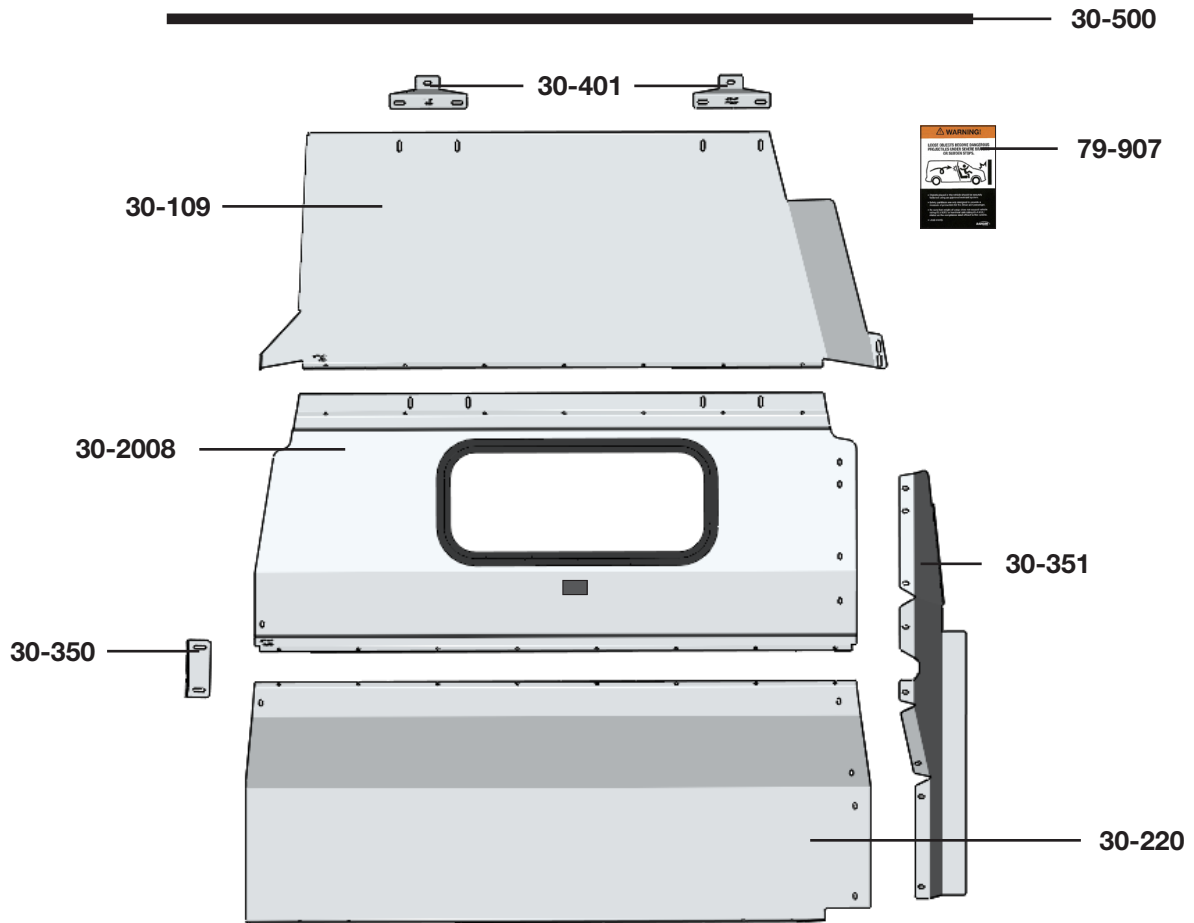

1.1.2 Verify all parts are present.

Item No.	Description	Qty.
30-109	Top Panel	1
30-220	Lower Panel	1
30-350	Driver Side Wing	1
30-351	Passenger Side Wing	1
30-401	Ceiling Bracket	2
30-500	Edge Trim (QTY in Inches)	174
79-907	Warning Label	1
30-2008	Upper Panel w/ Window	1
94-3037	Assembly Fastener Bag	1
96-3025	Installation Fastener Bag	1



1.1.3 Identify the **Assembly** and **Installation** fastener bags.

Assembly Fastener Bag →

- 29x  # 90-204 Hex Bolt
5/16"-18 x 3/4"
GR-5 ZINC
- 29x  # 94-116 Serrated Nut
5/16"-18
ZINC
- 29x  # 98-116 Flat Washer
5/16", 7/8" OD
ZINC

Hardware Assembly

29x

-  #90-204 Hex Bolt 5/16" x 3/4"
-  #98-116 Flat Washer
-  #94-116 Serrated Nut

Installation Fastener Bag →



- 2x  # 90-114 Hex Bolt
1/4"-20 x 1"
GR-5 ZINC
- 5x  # 90-666 Hex Bolt
M8-1.25 x 20 CL 8.8 DIN
933 BLACK OXIDE
- 4x  # 90-668 Hex Bolt
M8-1.25 x 40 CL 8.8 DIN
933 BLACK OXIDE
- 2x  # 94-130 Plusnut .250
- 2x  # 98-112 Flat Washer
1/4", 3/4" OD
ZINC
- 9x  # 98-116 Flat Washer
5/16", 7/8" OD
ZINC
- 2x  # 98-118 Lock Washer
Regular 1/4"
ZINC
- 9x  # 98-122 Lock Washer
Regular 5/6"
ZINC
- 8x  # 98-157 Spacer
0.375" ID, x 1.0" OD x 0.25" L
NYLON

Hardware Assembly

2x

-  #90-114 Hex Bolt 1/4" x 1"
-  #98-118 Lock Washer
-  #98-112 Flat Washer
-  #94-130 Plusnut .250

5x

-  #90-666 Hex Bolt M8 x 20
-  #98-122 Lock Washer
-  #98-116 Flat Washer

4x

-  #90-668 Hex Bolt M8 x 40
-  #98-122 Lock Washer
-  #98-116 Flat Washer
-  #98-157 Spacers (2)

PHASE 1 – ASSEMBLY

1.2 PARTITION ASSEMBLY

1.2.1 Remove all the PVC from all the parts, then attach upper panel to the lower panel.

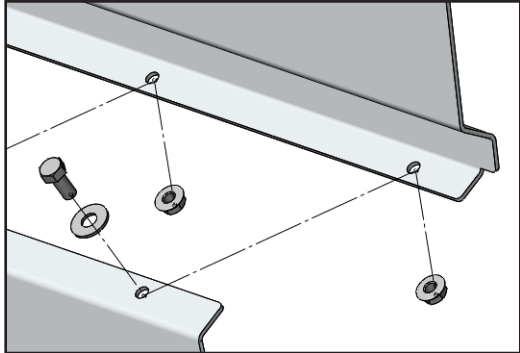
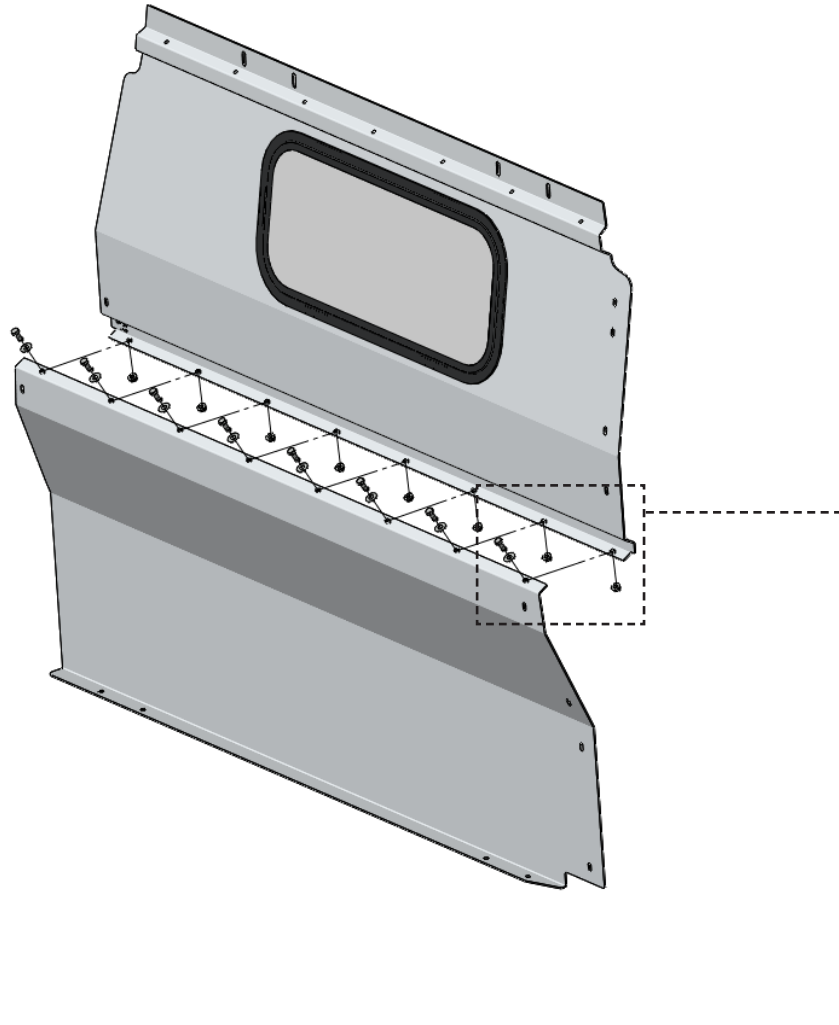



TOOLS

- Cordless Impact
- 1/2" Socket

HARDWARE USED

8x

	#90-204 Hex Bolt 5/16" x 3/4"
	#98-116 Flat Washer
	#94-116 Serrated Nut

1.2.2 Attach both wings to the upper and lower panels.

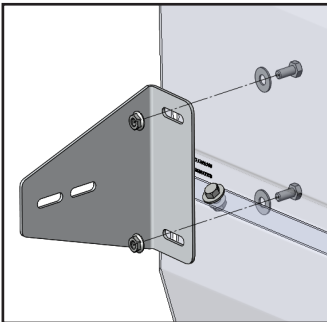
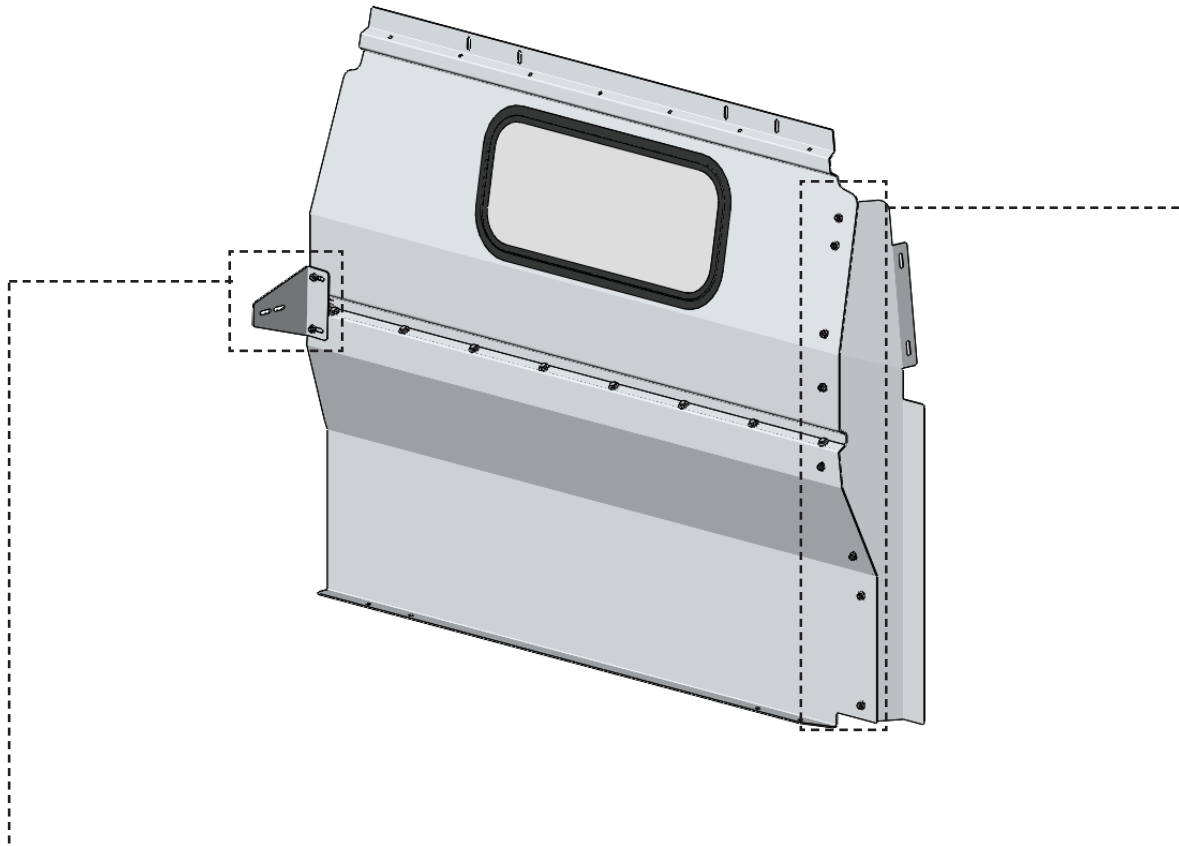



TOOLS

- Cordless Impact
- 1/2" Socket

HARDWARE USED

2x

-  #90-204 Hex Bolt 5/16" x 3/4"
-  #98-116 Flat Washer
-  #94-116 Serrated Nut

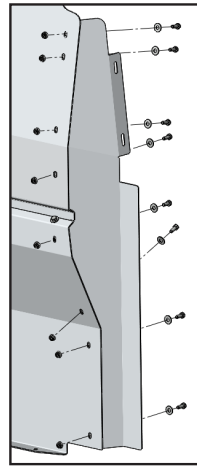

TOOLS

- Cordless Impact
- 1/2" Socket

HARDWARE USED

8x

-  #90-204 Hex Bolt 5/16" x 3/4"
-  #98-116 Flat Washer
-  #94-116 Serrated Nut

1.2.3 Attach the edge trims along both sides of the upper and lower panels.

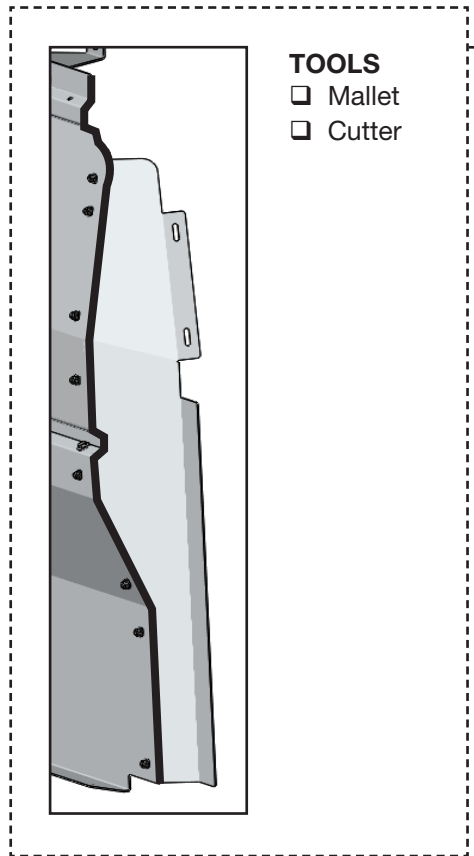
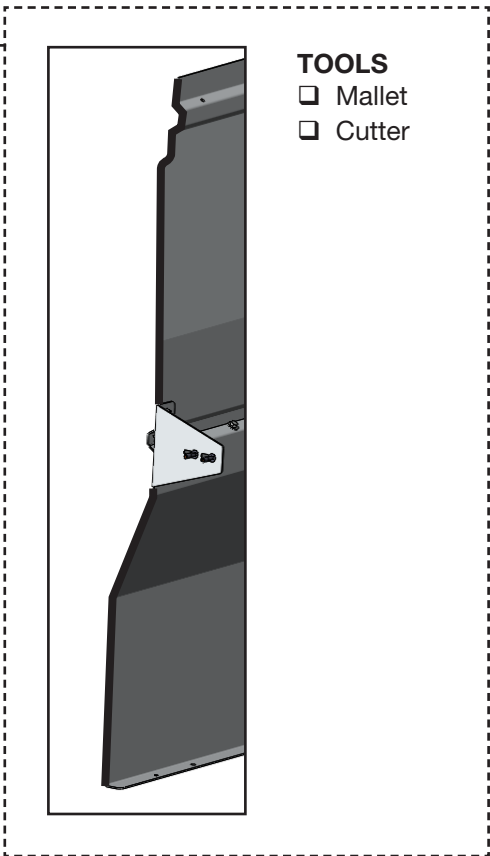
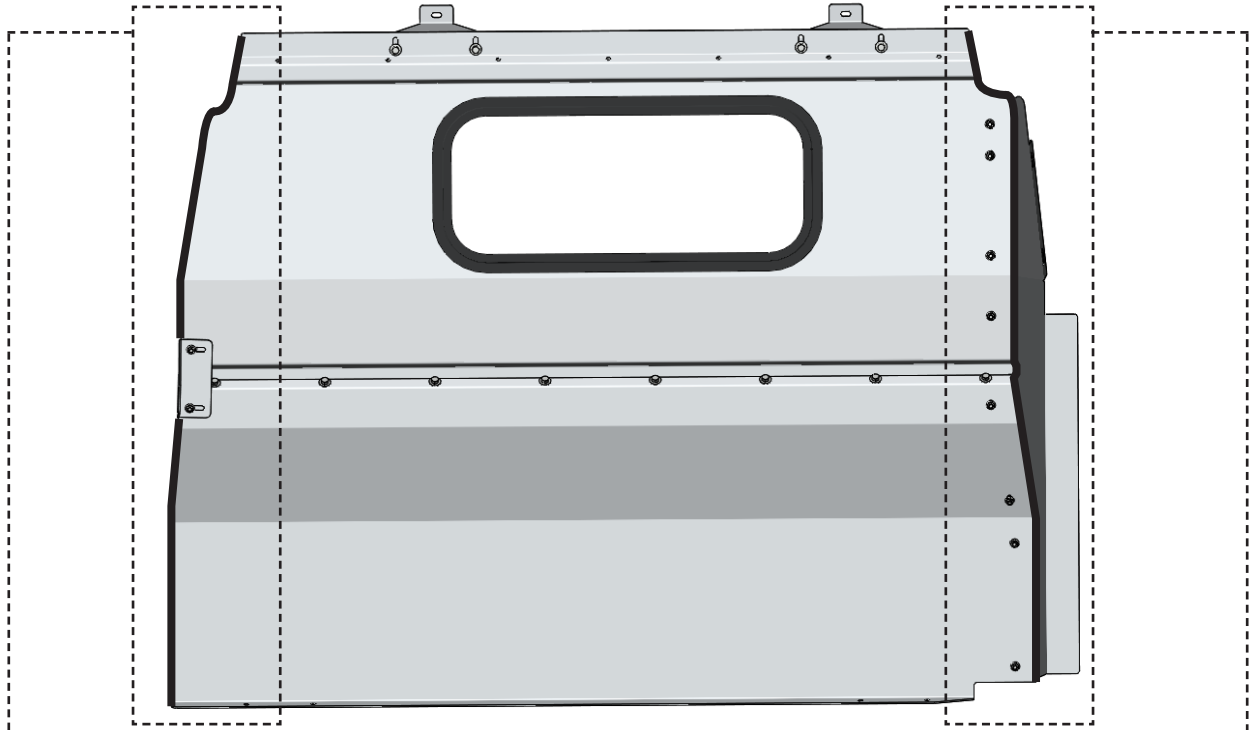

PHASE 2 – INSTALLATION

2.1 TIPS ON HOW TO ATTACH A PLUSNUT

2.1.1 Attach the plusnut using the plusnut gun.

TIPS: Put the plusnut on the plusnut gun, then attach the plusnut in the hole by turning the gun forward until the plusnut locks, then remove the gun by turning in reverse.

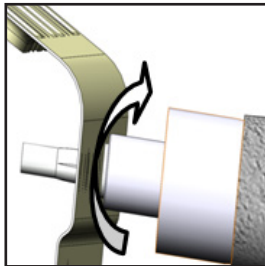

FORWARD

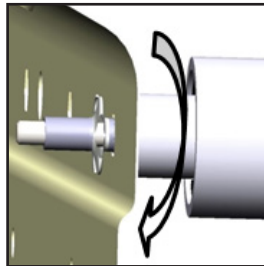

REVERSE

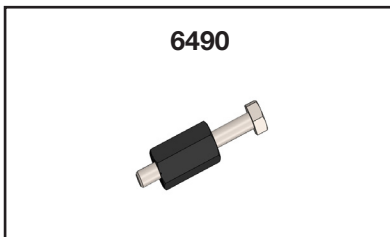

2.1.2 Attach the plusnut using the 6490 plusnut tool.

NOTE: The hardware used for the 6490 plusnut tool is not included in the fastener bag. The 6490 plusnut tool can be ordered separately upon demand at no charge.



6490

HARDWARE USED

-  Flat washer 1/4"
-  Flat washer 1/4" BS x 3/4" OD

- TOOLS**
- Cordless Impact
 - 7/16" Socket
 - 9/16" Wrench

TIPS STEP 1:
Assemble the 6490 plusnut tool with the hardware needed, plusnut and the 9/16" wrench as shown.

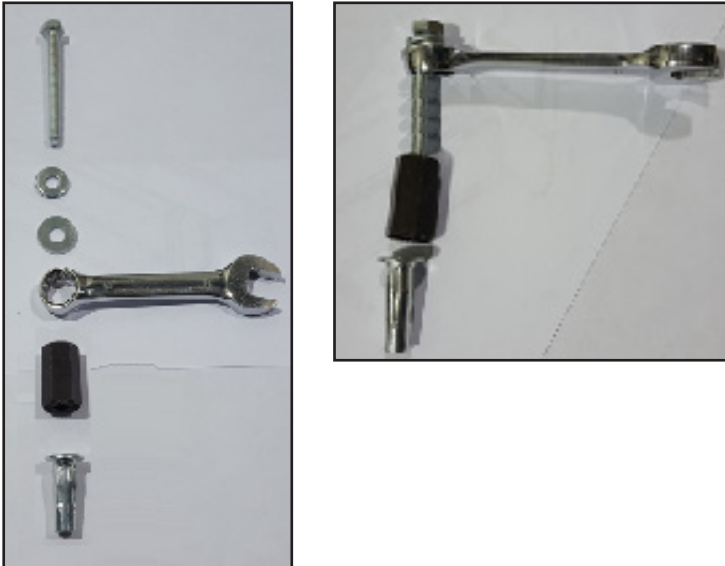

TIPS STEP 2:
Attach the plusnut in the hole by turning the bolt forward using an impact with a 7/16" socket until the plusnut locks, then remove the bolt by turning the impact in reverse.

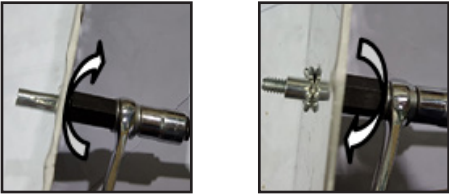

FORWARD **REVERSE**

PHASE 2 – INSTALLATION

2.2 VEHICLE PREPARATION

2.2.1 Remove the grab handle, the cap on the B-pillar and and the 2 D-rings in the van.

NOTE: Keep the hardware from the grab handle for re-use.

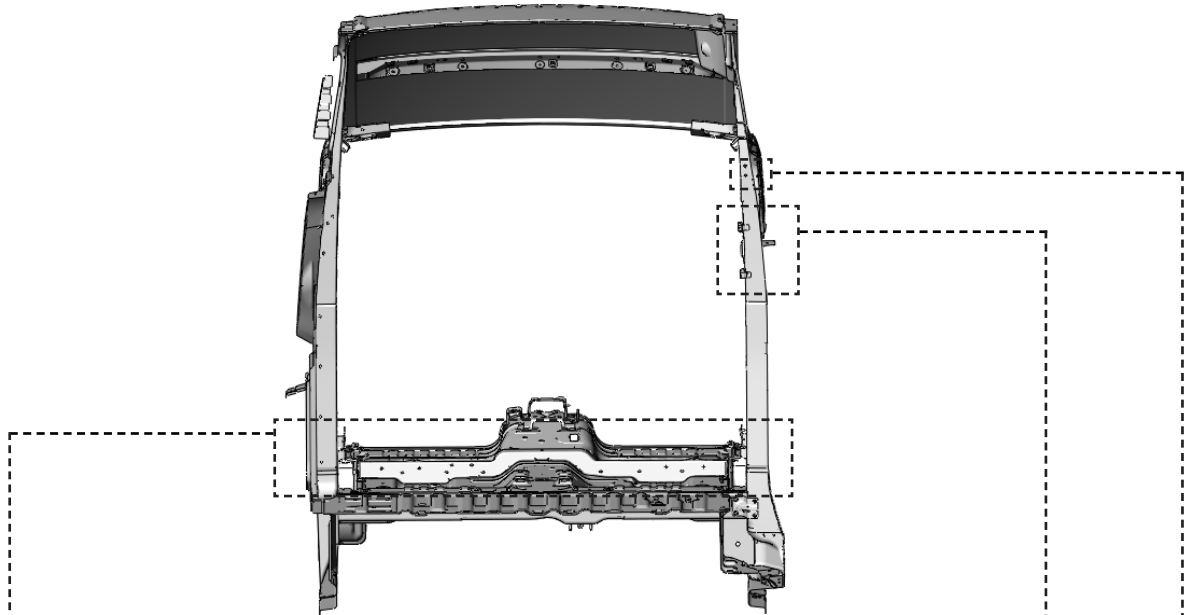

TOOLS

- Cordless Impact
- 13mm Socket



TOOLS

- Cordless Impact
- 13mm Socket



TOOLS

- Cordless Impact
- 13mm Socket

PHASE 2 – INSTALLATION

2.3 CONTOURED PARTITION INSTALLATION

2.3.1 Attach the 2 ceiling brackets in the van.

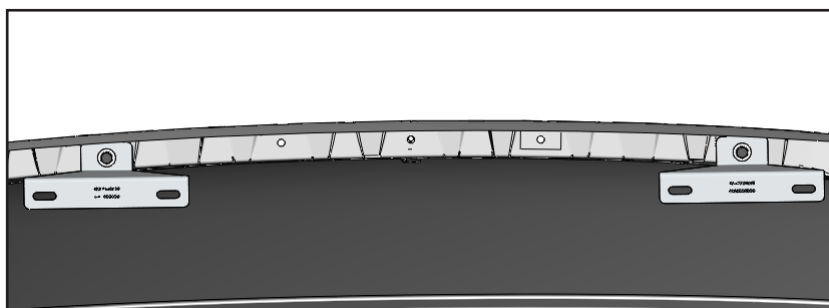
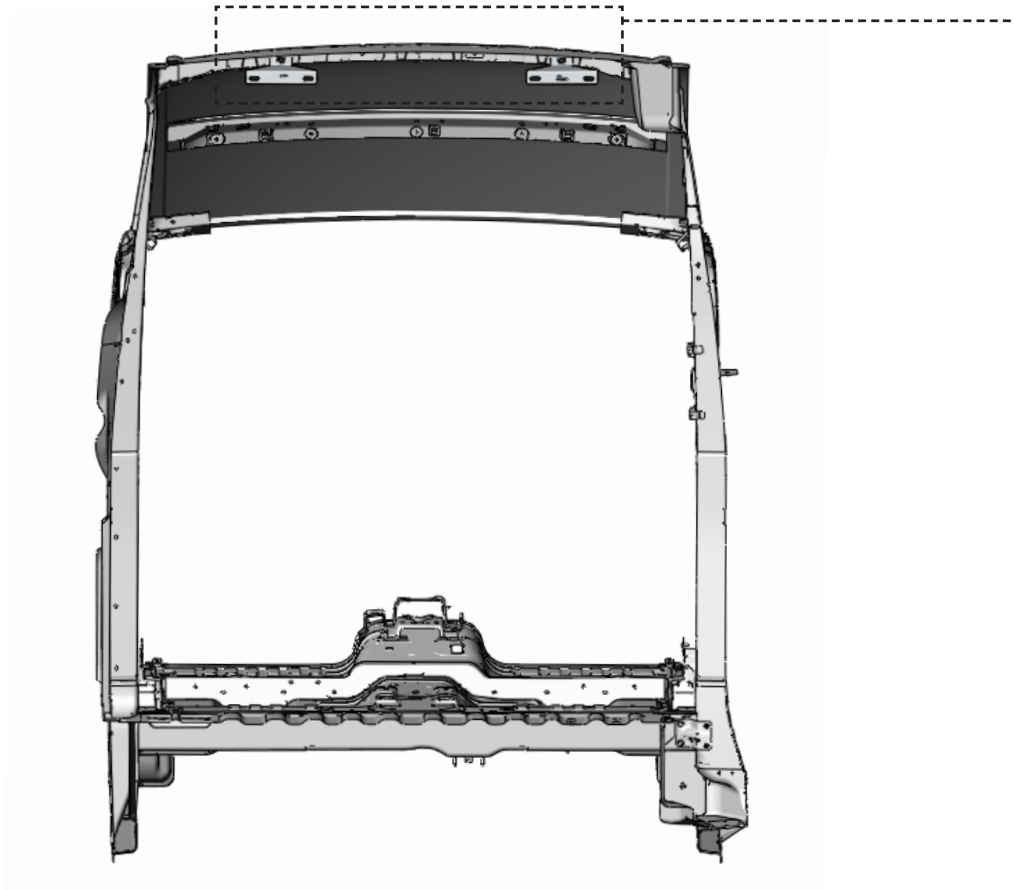



TOOLS

- Cordless Impact
- 13mm Socket

HARDWARE USED

2x

-  #90-666 Hex Bolt M8 x 20
-  #98-122 Lock Washer
-  #98-116 Flat Washer

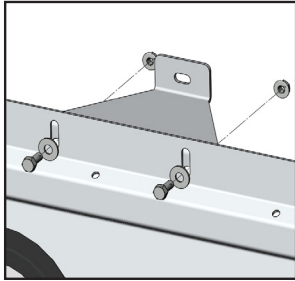

2.3.2 Attach the top panel to the ceiling brackets, then bolt the both sides of the top panel in the van



- TOOLS**
- Cordless Impact
 - 1/2" Socket

HARDWARE USED

4x

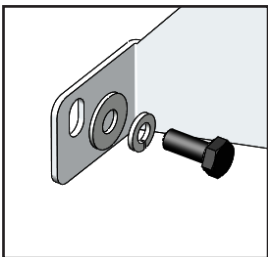
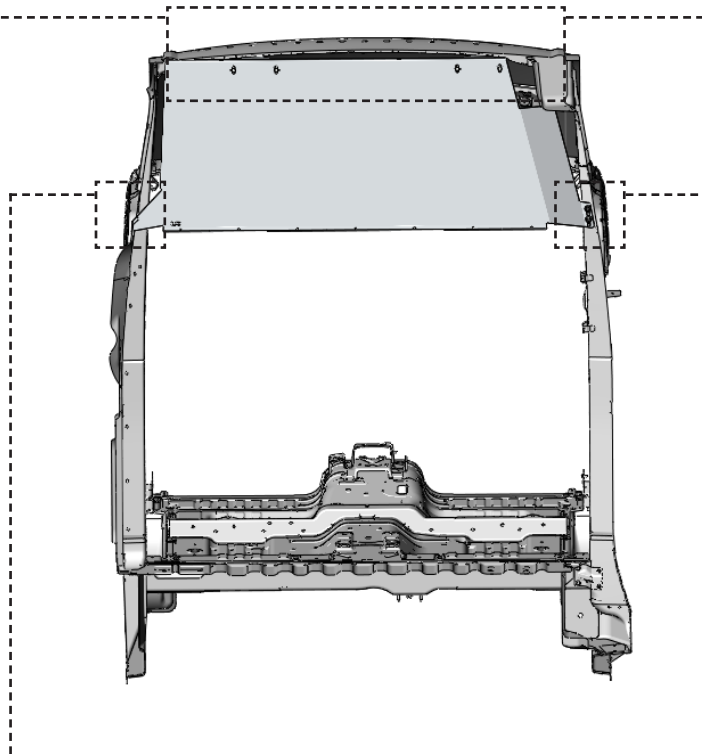

-  #90-204 Hex Bolt 5/16" x 3/4"
-  #98-116 Flat Washer
-  #94-116 Serrated Nut



- TOOLS**
- Cordless Impact
 - 13mm Socket

HARDWARE USED

1x

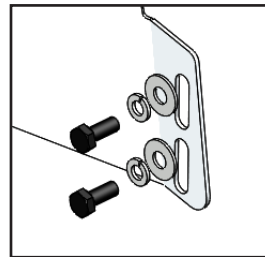

-  #90-666 Hex Bolt M8 x 20
-  #98-122 Lock Washer
-  #98-116 Flat Washer



- TOOLS**
- Cordless Impact
 - 13mm Socket

HARDWARE USED

2x

-  #90-666 Hex Bolt M8 x 20
-  #98-122 Lock Washer
-  #98-116 Flat Washer

2.3.3 Lift the assembled partition into the van, then attach plusnuts in the van.

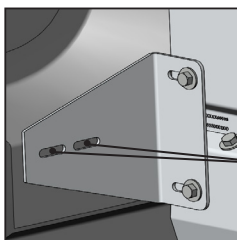
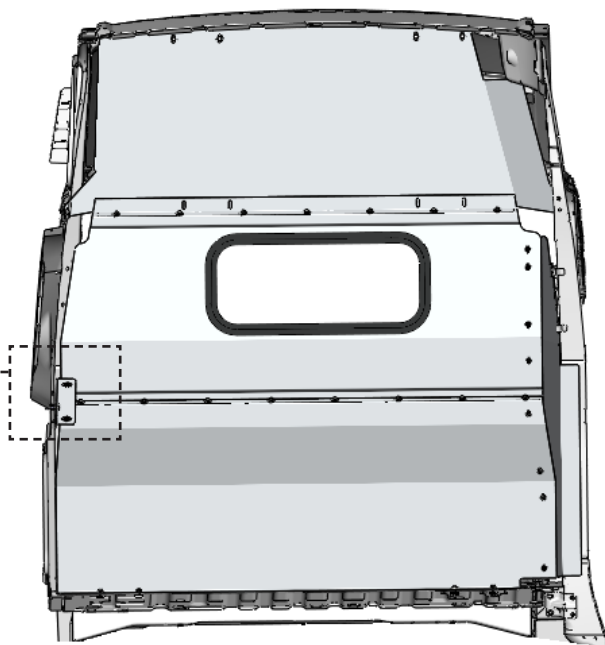

MARKS

Put the assembled partition in place, then put a mark on the van through the 2 holes of the driver side panel.

TOOLS

- Marker



Put the assembled partition on the side, then drill the 2 marks using 3/8" drill bit or step drill.

TOOLS

- Cordless Drill
- 3/8" Drill Bit or Step Drill



Attach a plusnuts in the 2 holes.

TOOLS

- Plusnut Tool

HARDWARE USED

2x



94-130
Plusnut .250

2.3.4 Attach the upper panel to the top panel.

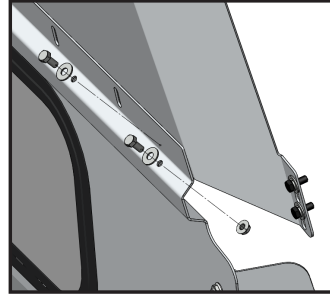
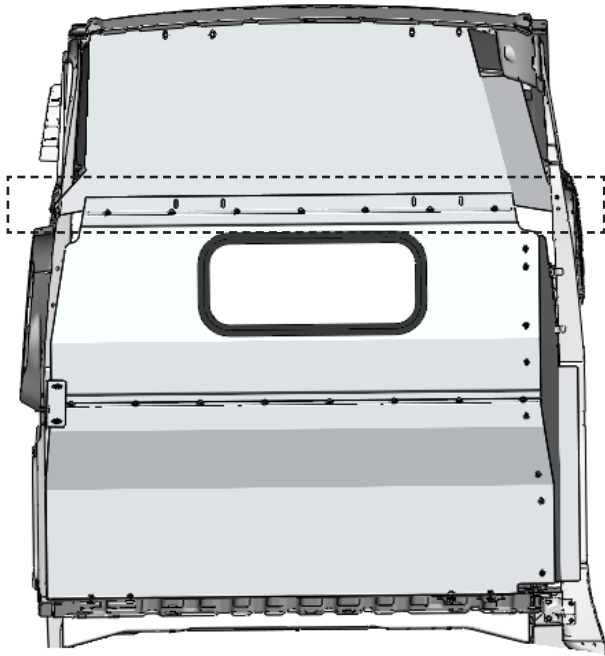



TOOLS

- Cordless Impact
- 1/2" Socket

HARDWARE USED

7x

-  #90-204 Hex Bolt 5/16" x 3/4"
-  #98-116 Flat Washer
-  #94-116 Serrated Nut

2.3.5 Bolt the lower panel in the van.

NOTE: Use spacers to level the floor.

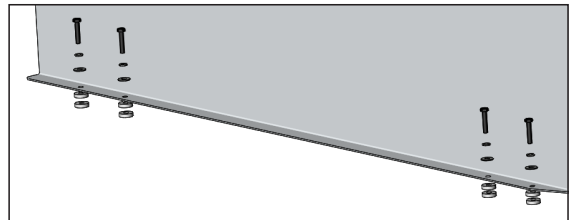
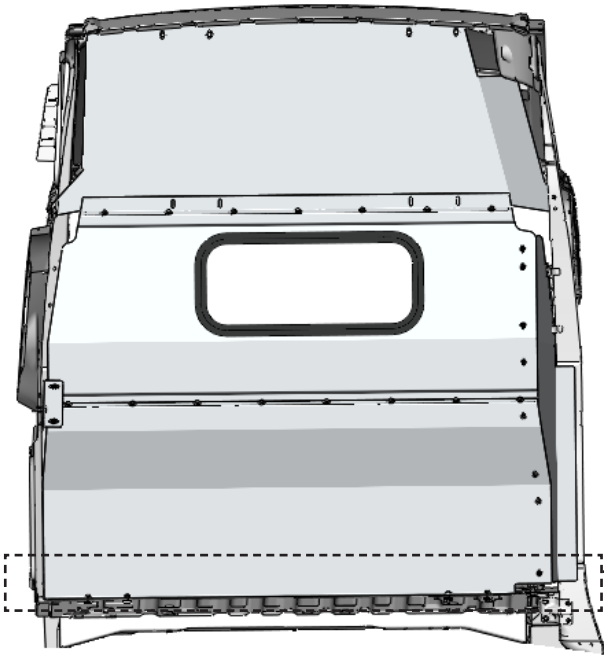





TOOLS

- Cordless Impact
- 13mm Socket

HARDWARE USED

4x

-  #90-668 Hex Bolt M8 x 40
-  #98-122 Lock Washer
-  #98-116 Flat Washer
-  #98-157 Spacers (2)

2.3.6 Bolt both wings of the partition in the van.

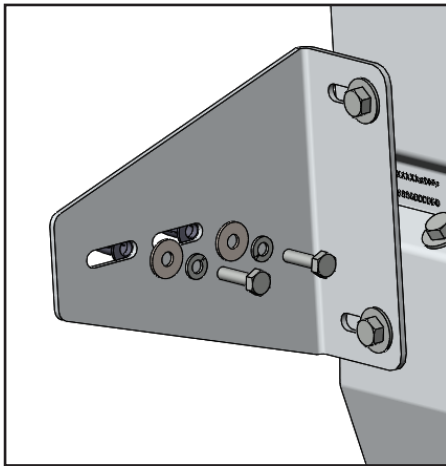
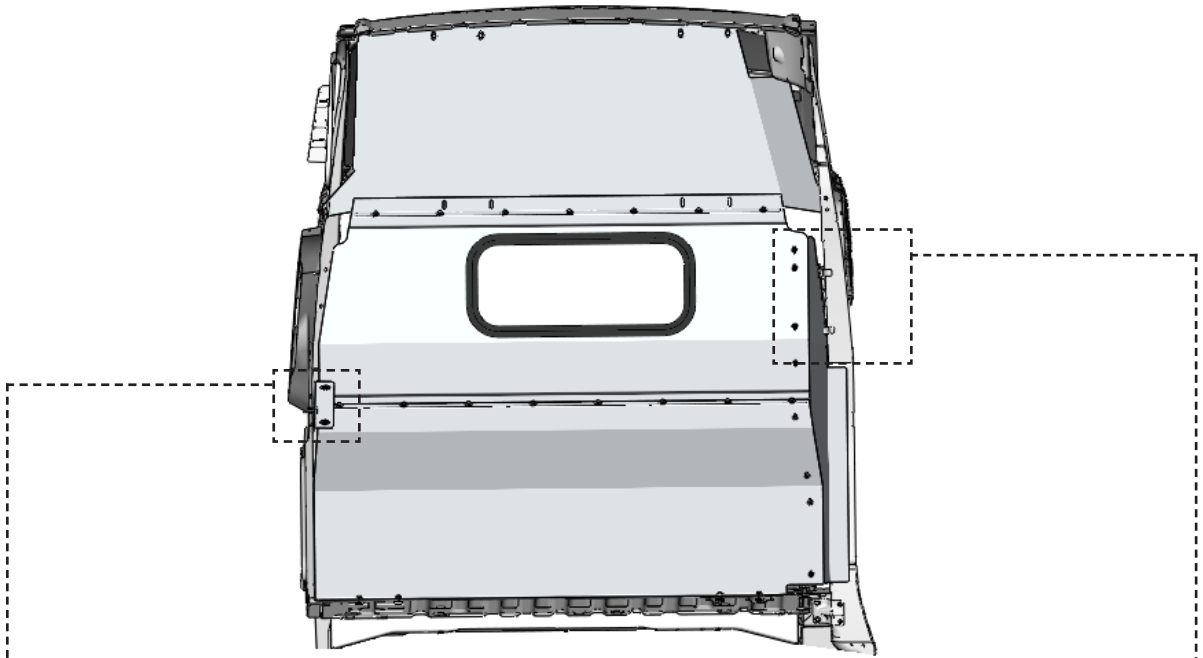

TOOLS

- Cordless Impact
- 7/16" Socket

HARDWARE USED

2x

-  #90-114 Hex Bolt 1/4" x 1"
-  #98-118 Lock Washer
-  #98-112 Flat Washer

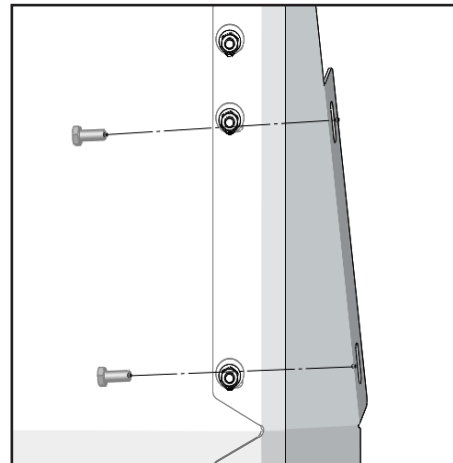

TOOLS

- Cordless Impact
- 10mm Socket

HARDWARE USED

2x

Use the hardware from the grab handle.

2.3.7 Apply the warning label on the passenger side panel and re-install the grab handle on the upper panel of the partition.

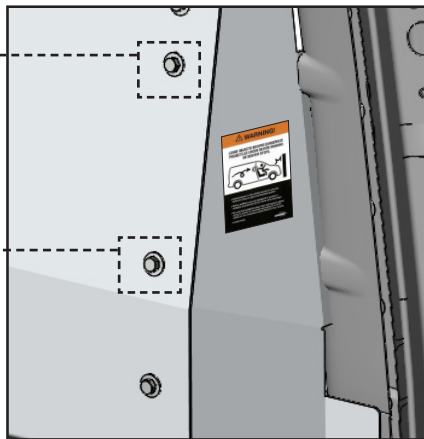
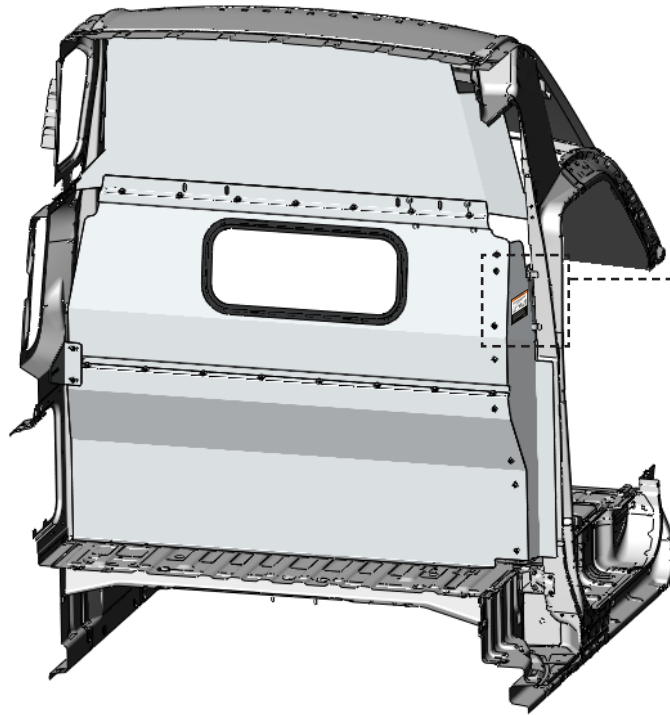

NOTE: Put the warning label in a place where it's easy to see.



NOTE: You can use these 2 bolts for the grab handle.

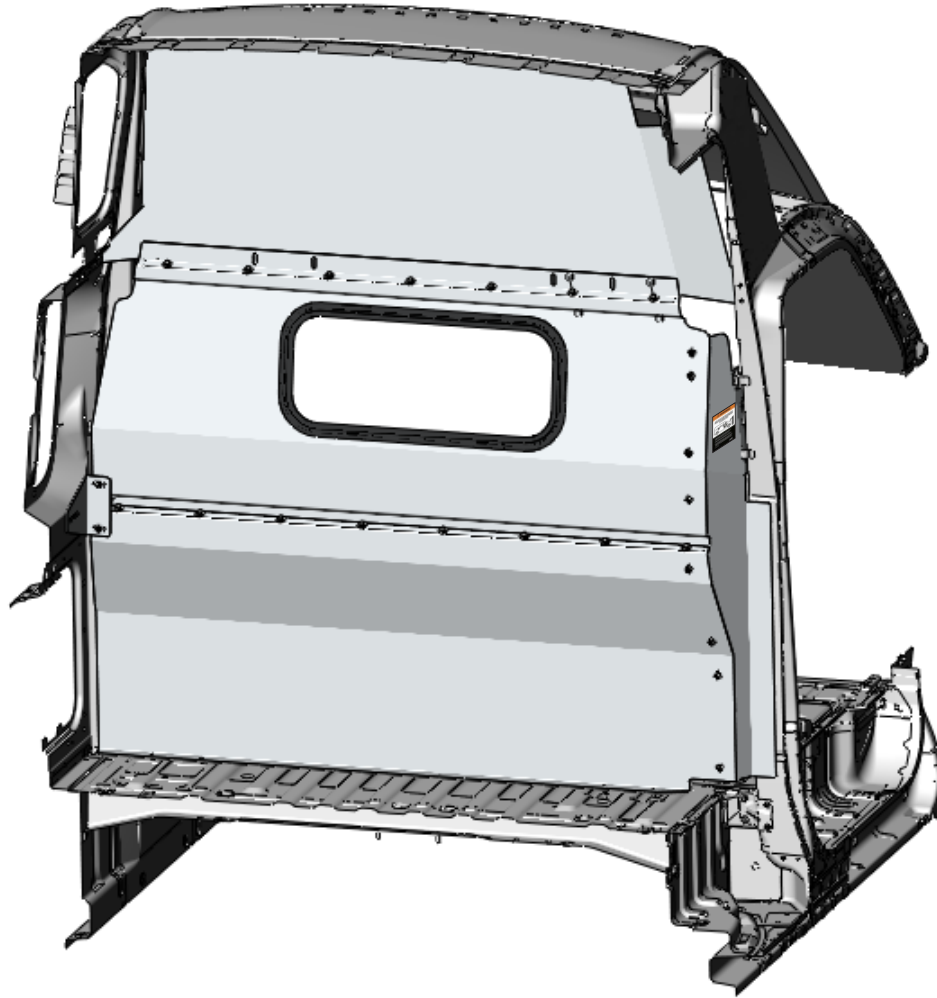

**“Congratulations, you have successfully installed your
Contoured Partition!”**

Thank you for doing business with us.”

