

INSTALLATION GUIDE

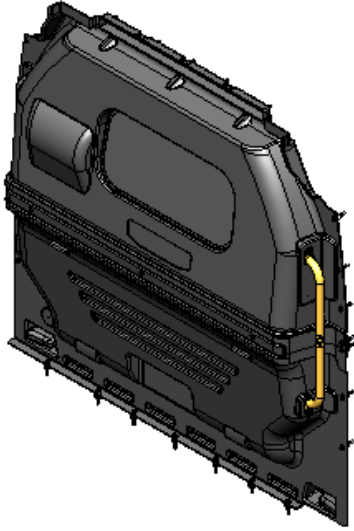

3310-DL

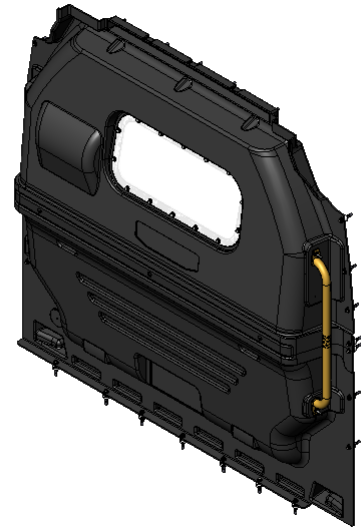

3320-DL

Composite Partition
Sprinter Low Roof

QUICK START GUIDE

Phase 1 - Assembly

<input type="checkbox"/> 1.1 Setup.....	3 - 4
<input type="checkbox"/> 1.2 Partition Assembly.....	5

Phase 2 - Install

<input type="checkbox"/> 2.1 Vehicle Preparation.....	6 - 7
<input type="checkbox"/> 2.2 Partition Installation.....	8
<input type="checkbox"/> 2.3 Handle Installation.....	9

REQUIRED ITEMS

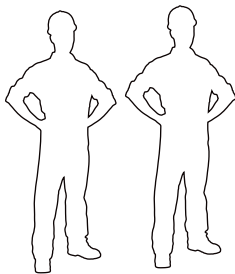

2
PERSONS

- Cordless Impact
- Cordless Drill
- Marker
- Plusnut Tool
- Tape Measure
- 3/8" Drill Bit
- 7/16" Socket
- 1/2" Socket
- 9/16" Wrench
- 10mm Socket

PHASE 1 – ASSEMBLY

1.1 SETUP

1.1.1 Unpack components; compare with the bill of materials.

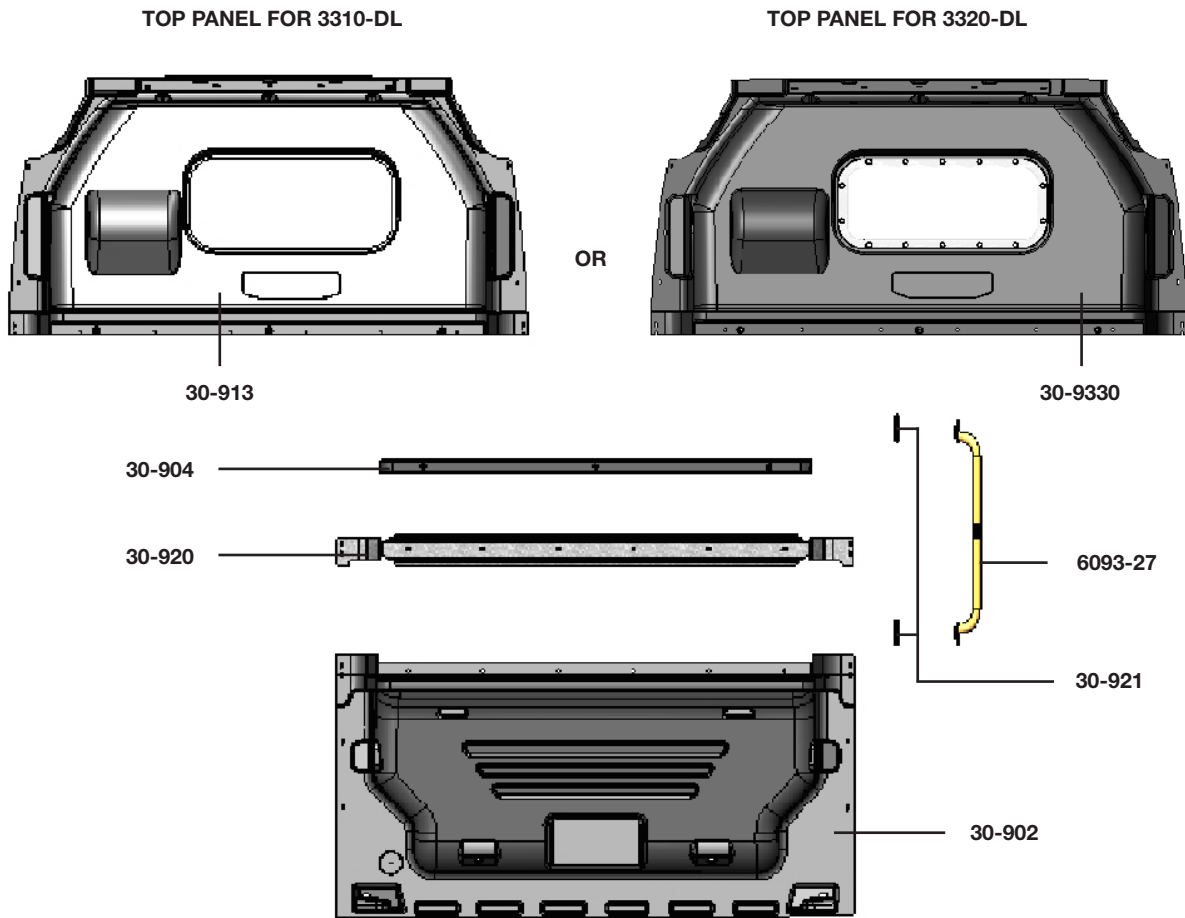

1.1.2 Verify all parts are present.

Item No.	Description	Qty.
30-902	Bottom Panel	1
30-904	Bolt Cap	1
30-913 OR 30-9330	Top Panel	1
30-920	Support	1
30-921	Handle Plate	2
6093-27	Large Grab Handle	1
94-5017	Assembly Fastener Kit	1
96-3044	Install Fastener Kit	1

1.1.3 Identify the **Assembly** and **Installation** fastener bags.

94-5017

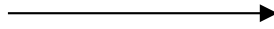

Hardware Assembly

x6

	#90-490 Carriage Bolt 1"
	#98-116 Flat Washer
	#98-122 Lock Washer
	#94-104 Hex Nut

x3

	#99-109 Christmas tree plug
--	-----------------------------

96-3044

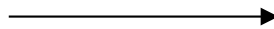

Hardware Assembly

x5

	#90-114 Hex Bolt 1"
	#98-118 Lock Washer
	#98-112 Flat Washer
	#94-130 Plusnut

x7

	#90-130 Hex Bolt 2"
	#98-118 Lock Washer
	#98-112 Flat Washer
	#98-157 Spacer
	#94-130 Plusnut

x14

	#90-130 Hex Bolt 2"
	#98-118 Lock Washer
	#98-112 Flat Washer
	#98-161 Spacer
	#98-158 Retaining Washer
	#94-130 Plusnut

PHASE 1 – ASSEMBLY

1.2 PARTITION ASSEMBLY

1.2.1 Attach the top and bottom panel with support bracket.

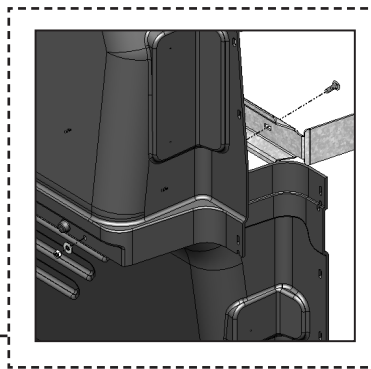
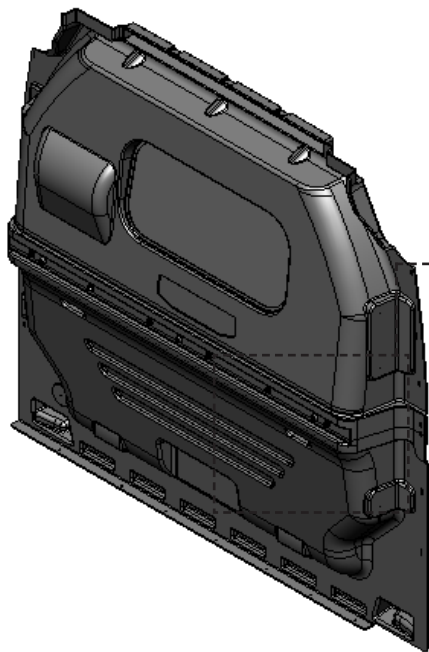





TOOLS

- Cordless Impact
- 1/2" Socket

HARDWARE USED

6x

	#90-490 Carriage Bolt 1"
	#98-116 Flat Washer
	#98-122 Lock Washer
	#94-104 Hex Nut

1.2.2 Plug the Bolt cap to the partition using Christmas tree plug.

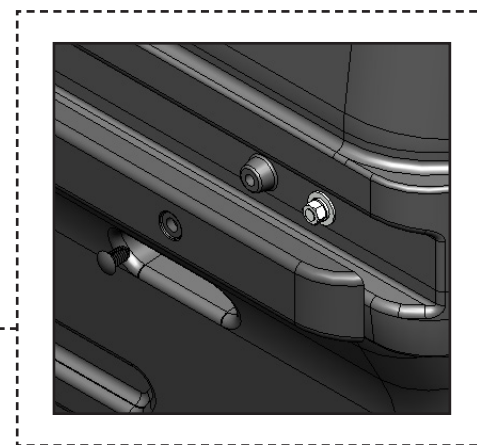
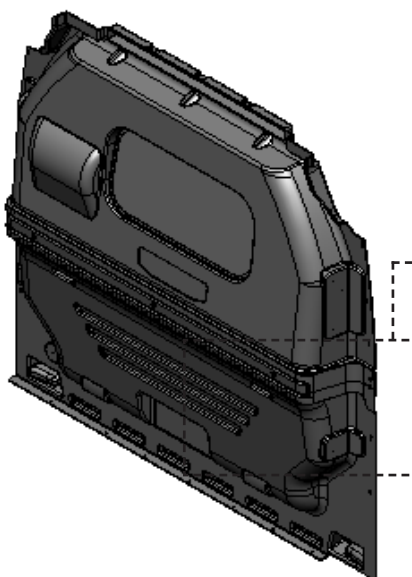

HARDWARE USED

3x

	#99-109 Christmas tree plug
---	-----------------------------

PHASE 2 – INSTALL

2.1 VEHICLE PREPARATION

2.1.1 Remove foam block.

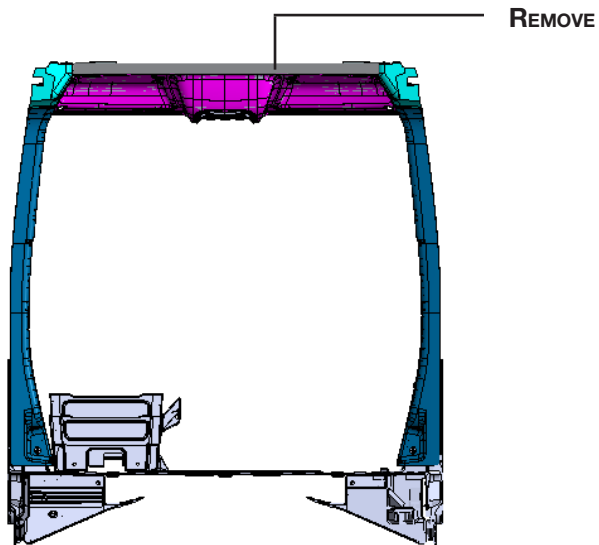

2.1.2 Lift the assembled partition in the van and put it in place, then mark all the hole.

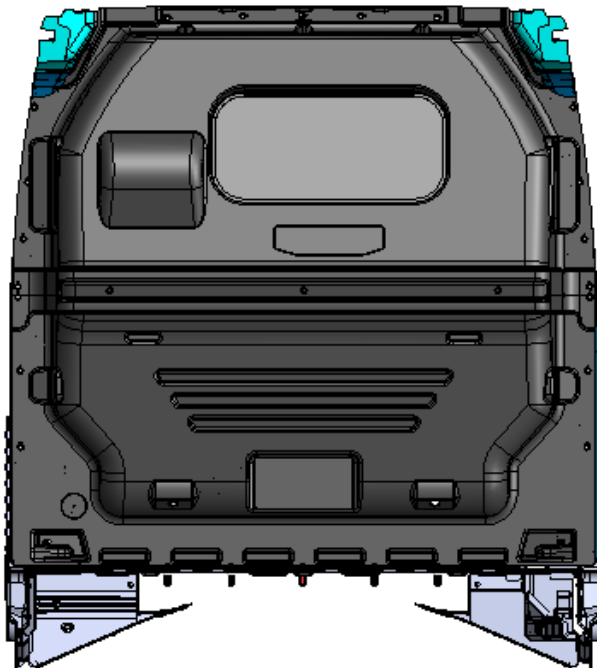

TOOLS

- Marker

2.1.3 Driver and passenger sides preparation.

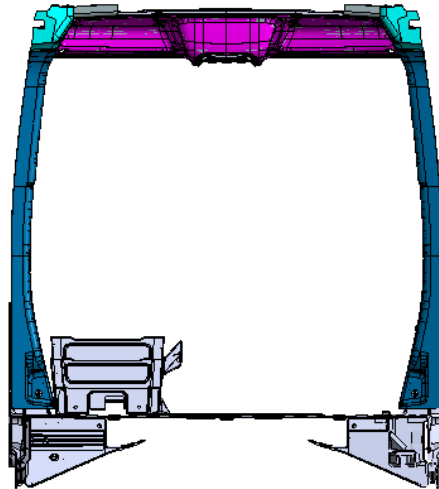

Use 1" hole saw to drill through the plastic cover and floor.

TOOLS

- 1" Hole Saw
- Cordless Drill

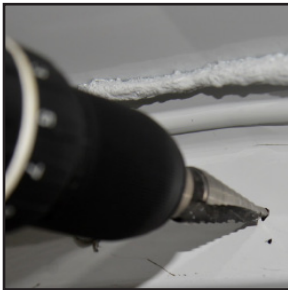

Check all holes of the partition if they are aligned in the holes of the van, then enlarge all the holes in the van that align with the holes of the partition using 3/8" drill bit or step drill.

- NOTE:**
- Make new holes in the van if the holes are not aligned with the hole of the partition.
 - If the van has a rubber or wood floor use a 1" hole saw to drill the floor and use a 3/8" drill bit or step drill to make a hole in the van (make sure the holes are aligned with the holes of the partition.)

TOOLS

- Cordless Drill
- 3/8" Drill Bit or Step Drill
- 1" Hole Saw



Attach a plusnuts in the holes.

TOOLS

- Plusnut Tool

HARDWARE USED

24x



94-130
Plusnut .250

PHASE 2 – INSTALL

2.2 PARTITION INSTALLATION

2.2.1 Lift and place the partition back on the van, then attach the partition to the van.

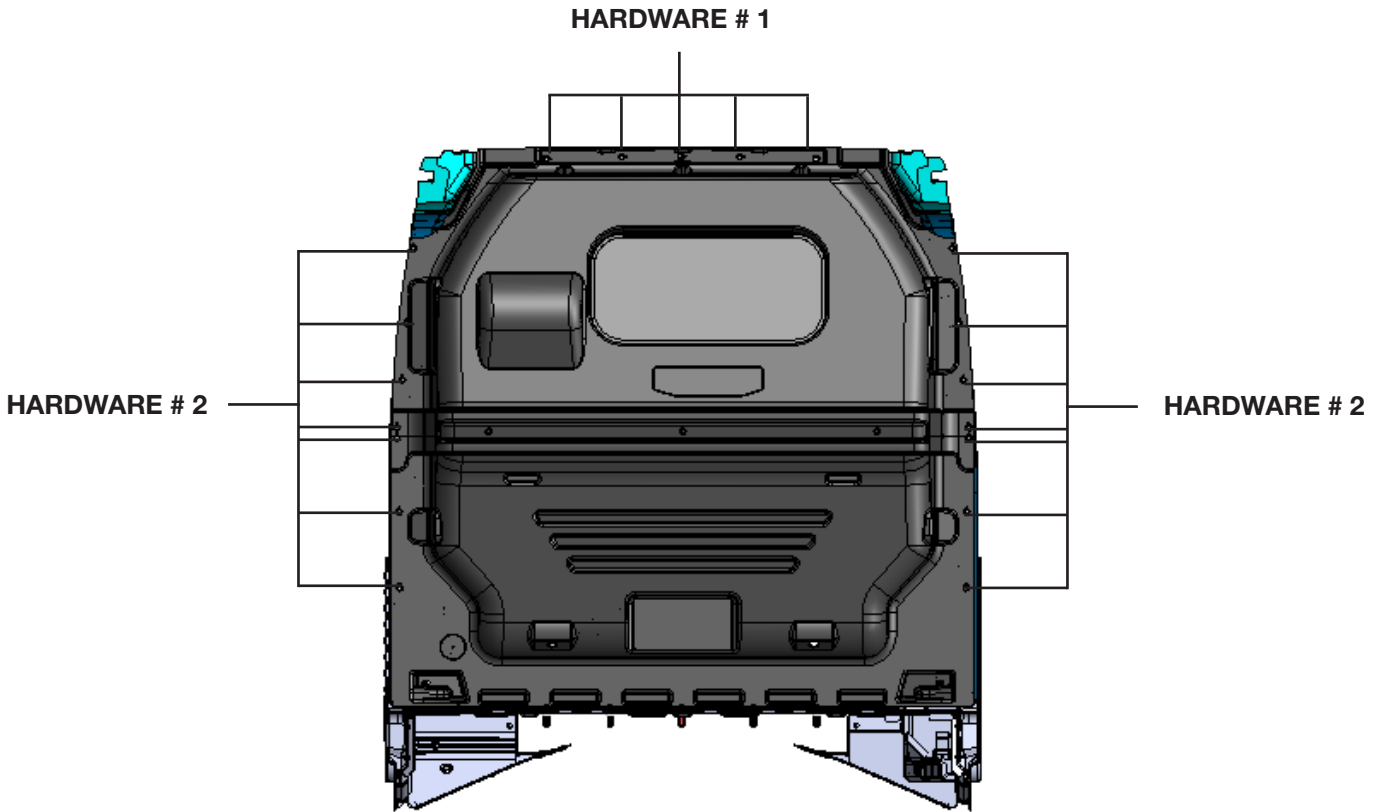





HARDWARE # 1

TOOLS

- Cordless Impact
- 7/16" Socket

HARDWARE USED

5x

-  #90-114 Hex Bolt 1"
-  #98-118 Lock Washer
-  #98-112 Flat Washer
-  #94-130 Plusnut







HARDWARE # 1

TOOLS

- Cordless Impact
- 7/16" Socket

HARDWARE USED

14x

-  #90-130 Hex Bolt 2"
-  #98-118 Lock Washer
-  #98-112 Flat Washer
-  #98-161 Spacer
-  #98-158 Retaining Washer
-  #94-130 Plusnut



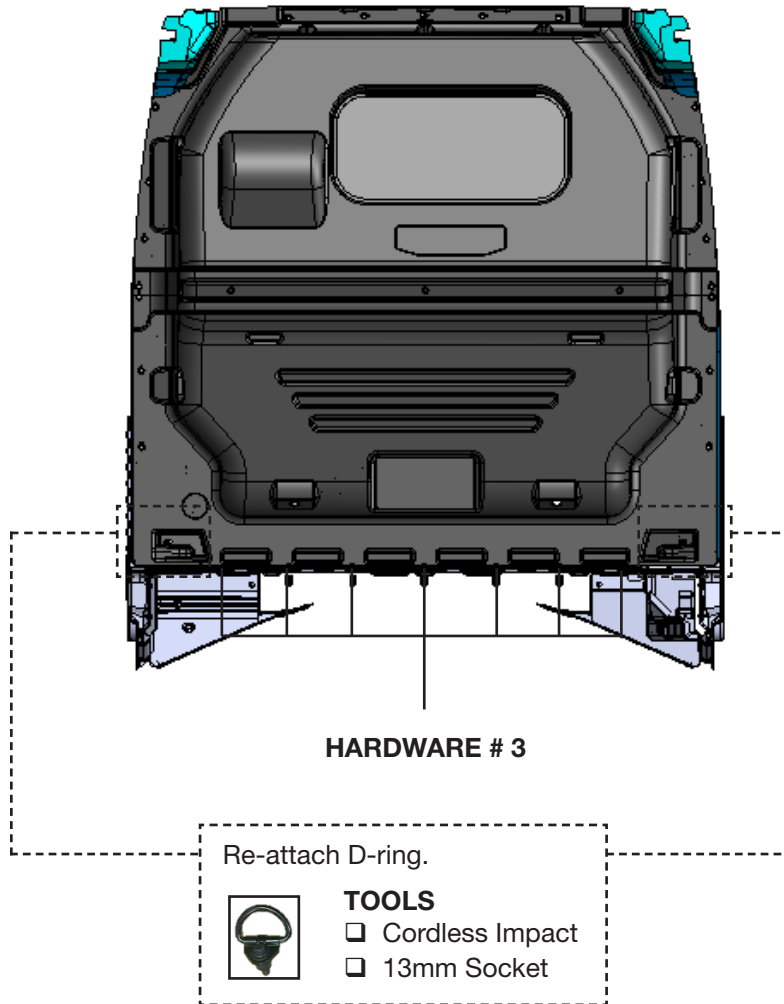

2.2.2 Bolt the bottom of the partition to the floor.



HARDWARE # 3

HARDWARE USED

7x

	#90-130 Hex Bolt 2"
	#98-118 Lock Washer
	#98-112 Flat Washer
	#98-157 Spacer
	#94-130 Plusnut

TOOLS

- Cordless Impact
- 7/16" Socket

PHASE 2 – INSTALLATION

2.3 HANDLE INSTALLATION

2.3.1 Attach the handle on the passenger side of the van.

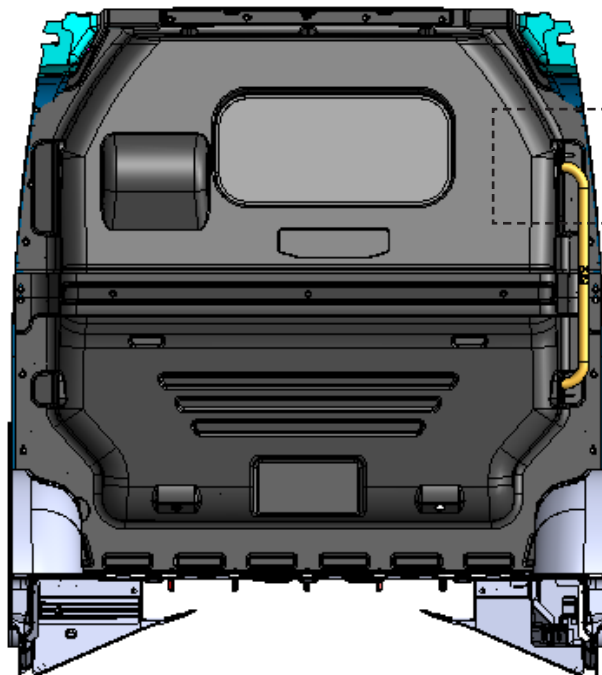

INSIDE

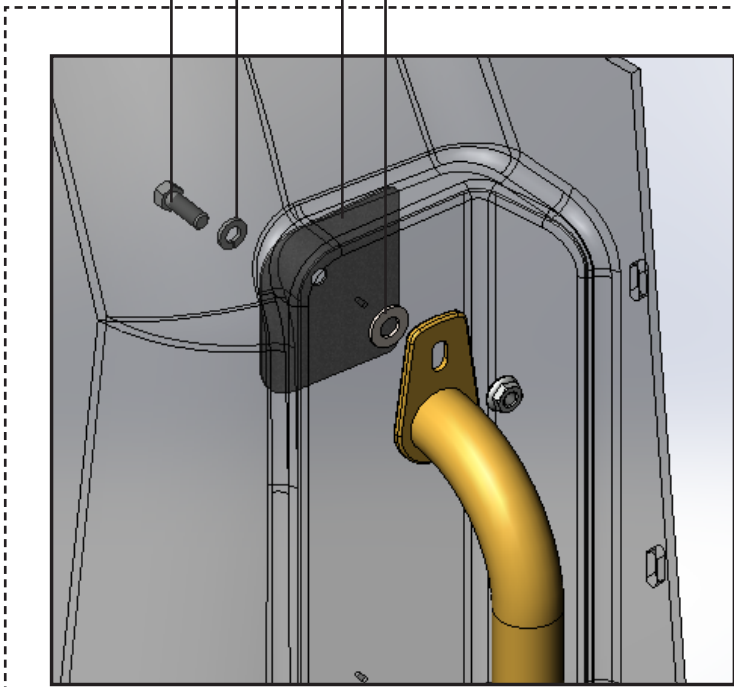





NOTE: You need to enlarge the hole in the partition panel.

TOOLS

- Cordless Impact
- Cordless Drill
- 1/2" Socket
- 3/8" Drill Bit

HARDWARE USED

2x GRAB HANDLE FASTENER KIT

- | | |
|---|-------------------------------|
|  | #90-206 Hex Bolt 5/16" x 7/8" |
|  | #98-122 Lock Washer |
|  | #98-116 Flat Washer |
|  | #94-116 Serrated Nut |

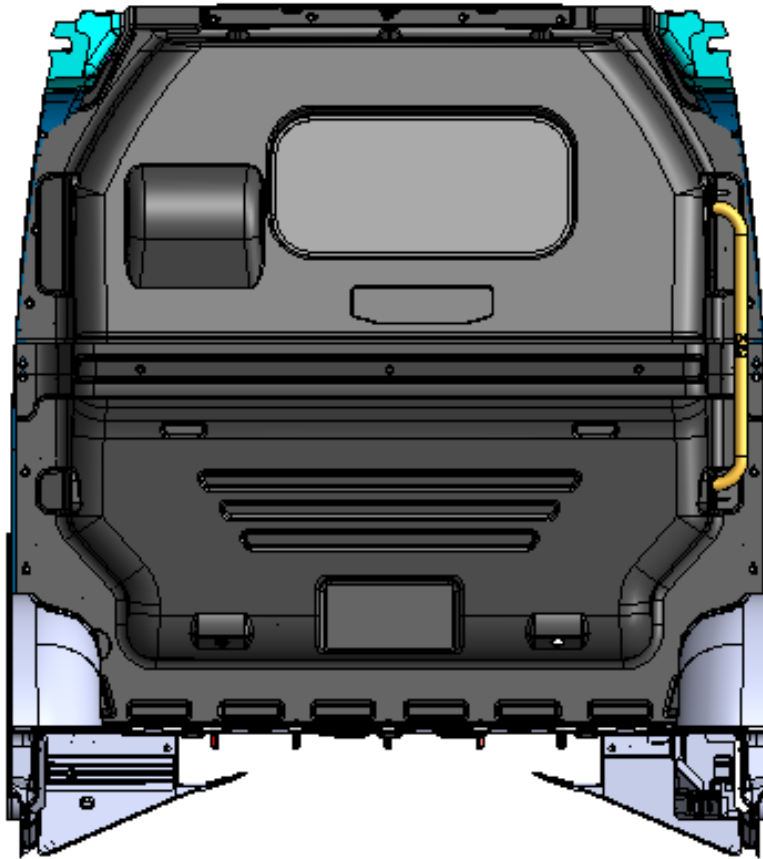

**“You have successfully installed your
Partition**

Thank you for doing business with us.”

For any feedback or suggestions you may have, please contact: cs@rangerdesign.com

