

INSTALLATION GUIDE

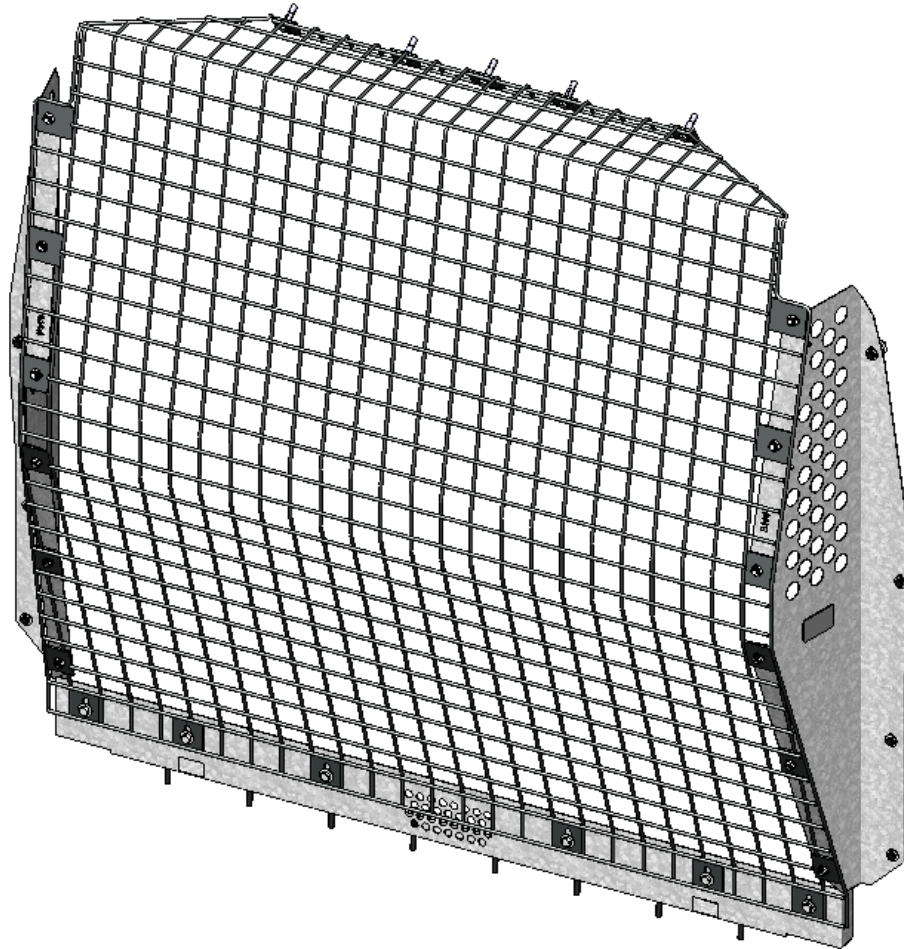

C13-PC WIRE MESH PARTITION

Promaster City (Wire Mesh, Steel)



QUICK START GUIDE

Phase 1 - Assembly

- 1.1 Setup..... 3
 - 1.1.1 Unpack components; compare with the bill of materials..... 3
 - 1.1.2 Verify all parts are present..... 3
 - 1.1.3 Identify the assembly and installation fastener bags..... 4
- 1.2 Partition Assembly..... 5
 - 1.2.1 Remove all the PVC from all the parts, then attach both wings to the wire mesh partition..... 5

Phase 2 - Installation

- 2.1 Tips on how to attach a plusnut..... 6
 - 2.1.1 Attach plusnut using plusnut gun..... 6
 - 2.1.2 Attach plusnut using Ranger plusnut tool..... 6
- 2.2 Vehicle preparation..... 7
 - 2.2.1 Removing handle..... 7
 - 2.2.2 Removing overhead plastic..... 8
 - 2.2.3 Driver and passenger sides preparation..... 9
 - 2.2.4 Ceiling and floor preparation..... 10
- 2.3 Wire mesh partition installation..... 11
 - 2.3.1 Attach the floor bracket in the van..... 11
 - 2.3.2 Lift the assembled partition in the van, then bolt both sides of the partition in the van..... 12
 - 2.3.3 Attach the top of the partition in the van..... 13
 - 2.3.4 Attach the bottom of the partition to the floor bracket..... 14
 - 2.3.5 Apply the warning label on the passenger side wing..... 15

REQUIRED ITEMS

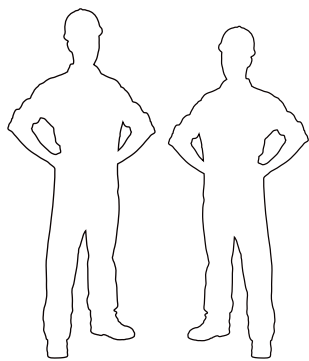

2
PERSONS

- Cordless Impact
- Cordless Drill
- Knife
- Philips Screw Driver
- Plusnut Tool
- Ratchet
- 1/2" Socket
- 7/16" Socket
- 10mm Socket
- 13mm Socket
- T30 Torque Bit
- T40 Torque Bit
- 9/16" Wrench
- 1" Holesaw

PHASE 1 – ASSEMBLY

1.1 SETUP

1.1.1 Unpack components; compare with the bill of materials.

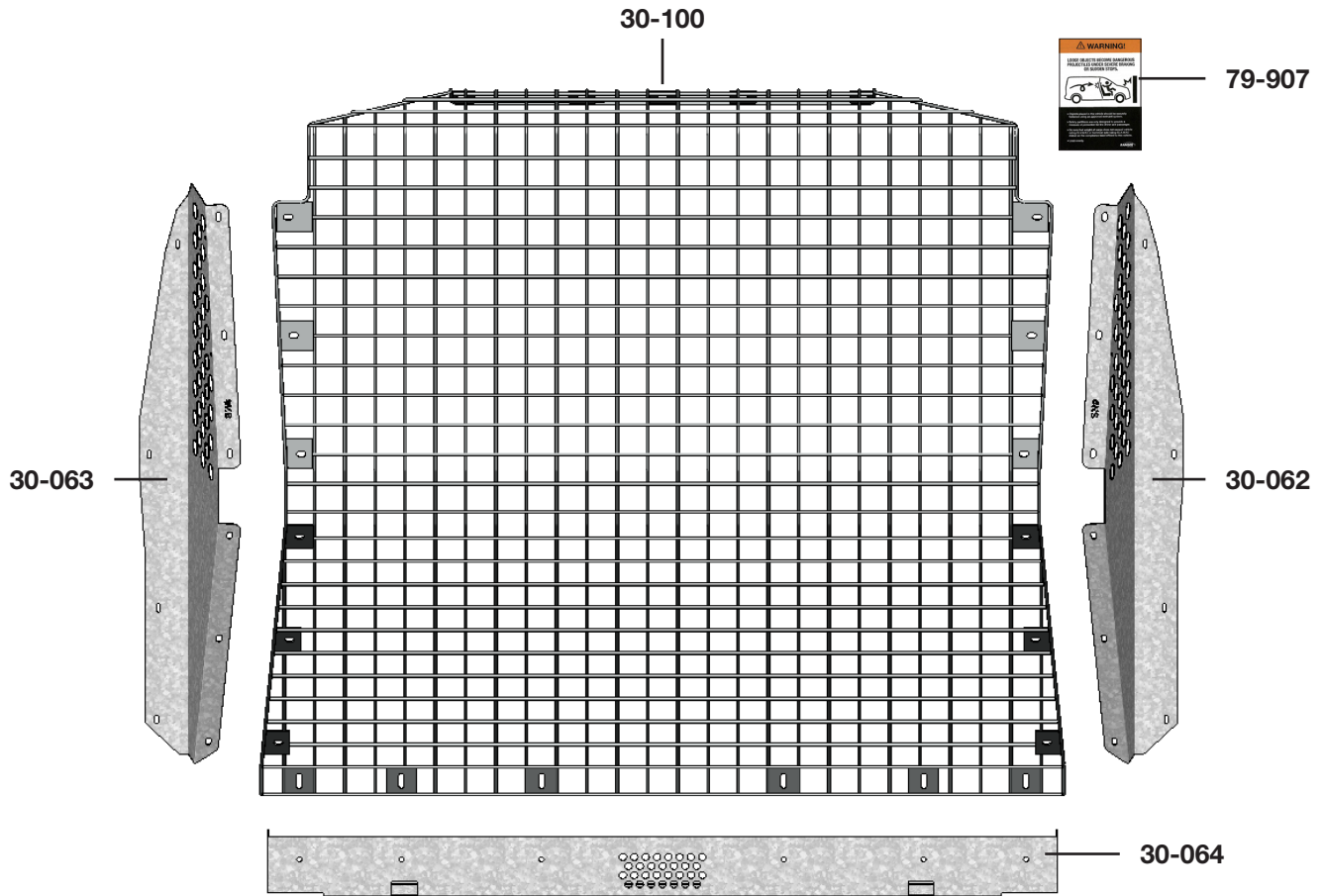





1.1.2 Verify all parts are present.

Item No.	Description	Qty.
30-062	Passenger Side Wing	1
30-063	Driver Side Wing	1
30-064	Floor Bracket	1
30-100	Wire Mesh Partition	1
79-907	Warning Label	1
94-3043	Assembly Fastener Bag	1
96-3012	Installation Fastener Bag	1



1.1.3 Identify the **Assembly** and **Installation** fastener bags.

Assembly Fastener Bag →

Hardware Assembly

- 6x  # 90-204 Hex Bolt
5/16"-18 x 3/4"
GR-5 ZINC
- 12x  # 90-484 Carriage Bolt
5/16"-18 x 5/8"
ZINC
- 18x  # 94-116 Serrated Nut
5/16"-18
ZINC
- 6x  # 98-116 Flat Washer
5/16", 7/8" OD
ZINC





- 6x
-  #90-204 Hex Bolt 5/16" x 3/4"
 -  #98-116 Flat Washer
 -  #94-116 Serrated Nut



- 12x
-  #90-484 Carriage Bolt 5/16" x 5/8"
 -  #94-116 Serrated Nut





Installation Fastener Bag →

Hardware Assembly

- 5x  # 90-118 Hex Bolt
1/4"-20 x 1-1/4"
GR-5 ZINC
- 8x  # 90-668 Hex Bolt
M8-1.25 x 40 CL 8.8 DIN
933 BLACK OXIDE
- 8x  # 90-836 Hex Bolt
M6-1.0 x 40 CL 12.9 DIN
933 BLACK OXIDE
- 5x  # 94-130 Plusnut .250
- 13x  # 98-112 Flat Washer
1/4", 3/4" OD
ZINC
- 8x  # 98-116 Flat Washer
5/16", 7/8" OD
ZINC
- 13x  # 98-118 Lock Washer
Regular 1/4"
ZINC
- 8x  # 98-122 Lock Washer
Regular 5/6"
ZINC
- 24x  # 98-157 Spacer
0.375" ID, x 1.0" OD x 0.25" L
NYLON
- 8x  # 98-158 Retaining Washer
M16 (1/4")
NYLON

- 5x
-  #90-118 Hex Bolt 1/4" x 1-1/4"
 -  #98-118 Lock Washer
 -  #98-112 Flat Washer
 -  #94-130 Plusnut .250

- 8x
-  #90-668 Hex Bolt M8 x 40
 -  #98-122 Lock Washer
 -  #98-116 Flat Washer

- 8x
-  #90-836 Hex Bolt M6 " x 40
 -  #98-118 Lock Washer
 -  #98-112 Flat Washer
 -  #98-157 Spacers (3)
 -  #98-158 Retaining Washer

PHASE 1 – ASSEMBLY

1.2 PARTITION ASSEMBLY

1.2.1 Remove all the PVC from all the parts, then attach both wings to the wire mesh partition.

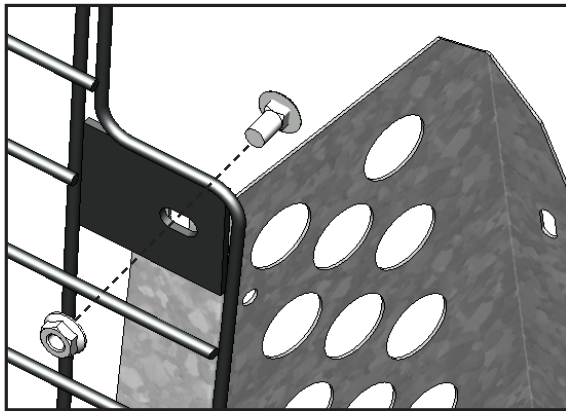
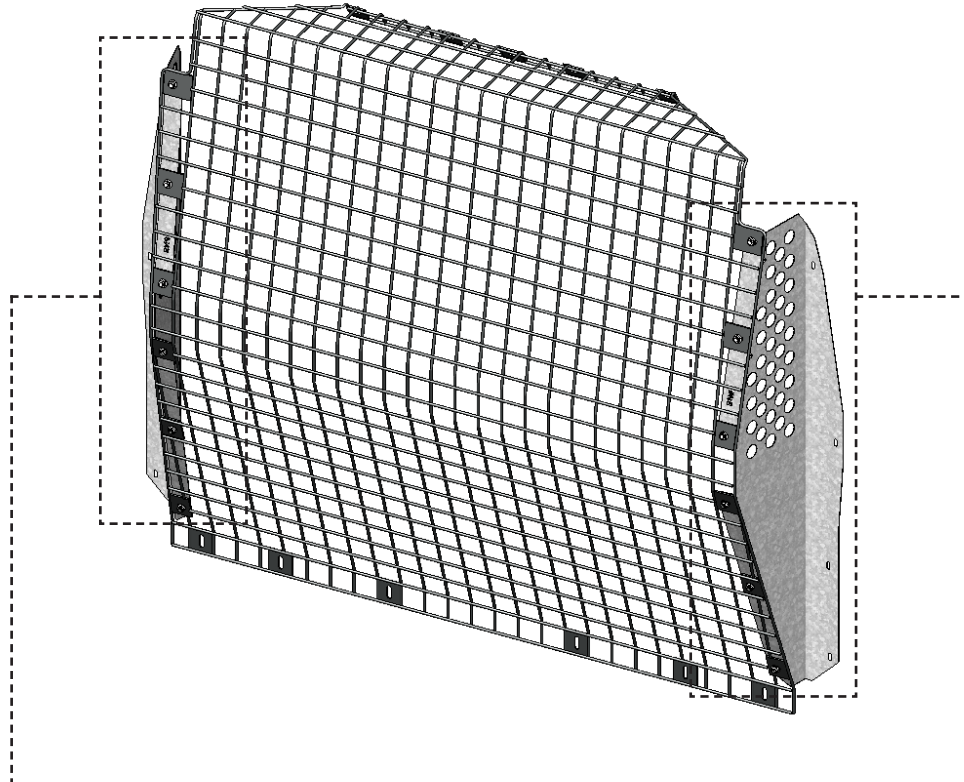

TOOLS

- Cordless Impact
- 1/2" Socket

HARDWARE USED

12x



#90-484 Carriage Bolt 5/16" x 5/8"



#94-116 Serrated Nut

PHASE 2 – INSTALLATION

2.1 TIPS ON HOW TO ATTACH A PLUSNUT

2.1.1 Attach the plusnut using the plusnut gun.

TIPS: Put the plusnut on the plusnut gun, then attach the plusnut in the hole by turning the gun forward until the plusnut locks, then remove the gun by turning in reverse.

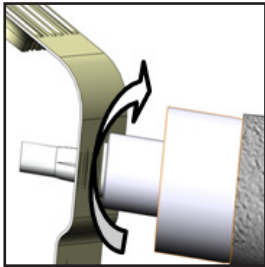

FORWARD

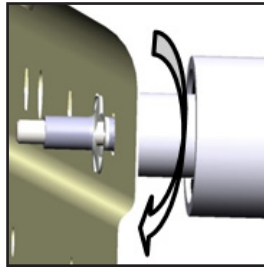

REVERSE

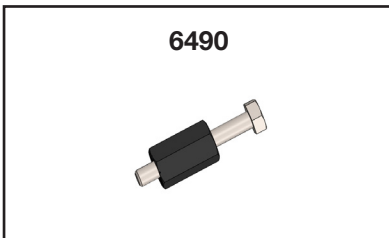

2.1.2 Attach the plusnut using the 6490 plusnut tool.

NOTE: The hardware used for the 6490 plusnut tool is not included in the fastener bag. The 6490 plusnut tool can be ordered separately upon demand at no charge.



6490

HARDWARE USED

-  Flat washer 1/4"
-  Flat washer 1/4" BS x 3/4" OD

TOOLS

- Cordless Impact
- 7/16" Socket
- 9/16" Wrench

TIPS STEP 1:

Assemble the 6490 plusnut tool with the hardware needed, plusnut and the 9/16" wrench as shown.



TIPS STEP 2:

Attach the plusnut in the hole by turning the bolt forward using an impact with a 7/16" socket until the plusnut locks, then remove the bolt by turning the impact in reverse.

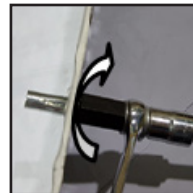

FORWARD

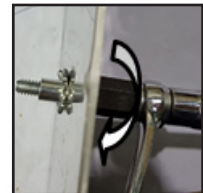

REVERSE

PHASE 2 – INSTALLATION

2.2 VEHICLE PREPARATION

2.2.1 Removing handle.

NOTE: If you are installing a Contoured Partition and your Promaster City is supplied with an oversized sliding door handle, this handle must be removed in order for the door to close properly.

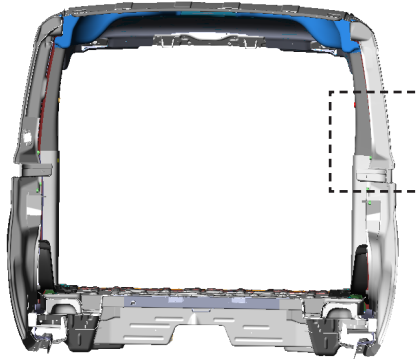

Separate the two halves of the handle exposing the two bolts at the top by removing the small philips screws and the bolt at the bottom.

TOOLS

- Cordless Impact or Ratchet
- Philips Screw Driver
- T30 Torque Bit



Detach the plastic bracket on the cable from the metal part of the handle, then slide the cable across the channel and pop out.

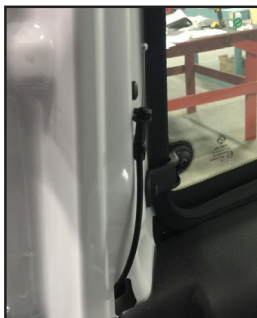

Tape or roll the cable.

NOTE: Pulling the cable unlocked the door.

2.2.2 Removing overhead plastic.

NOTE: There are two types of covers.

(White Covers - Without OEM partition, and Black Covers - With OEM partition)

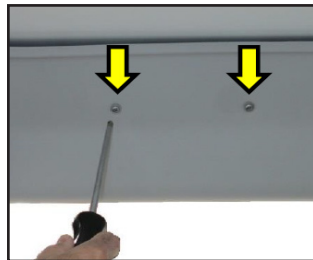
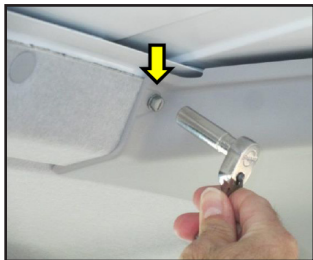
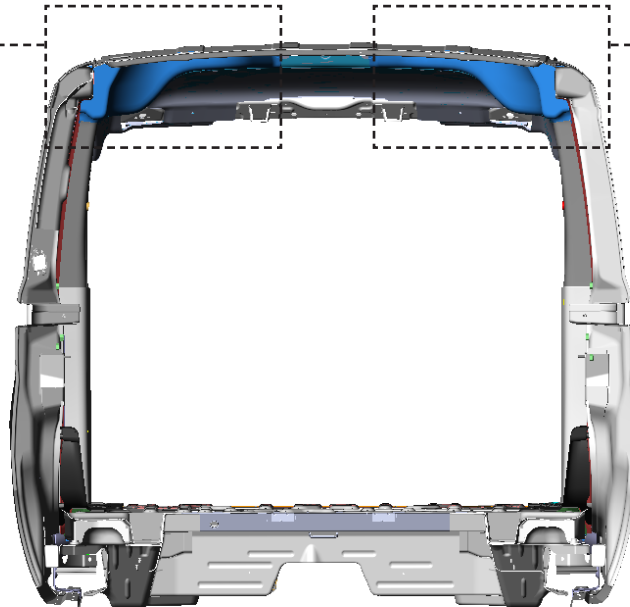

For the white cover, remove the two screws on the side and bolt on the front.

NOTE: Do these on both sides of the van.

TOOLS

- Cordless Impact or Ratchet
- Phillips Screw Driver
- 7/16" Socket

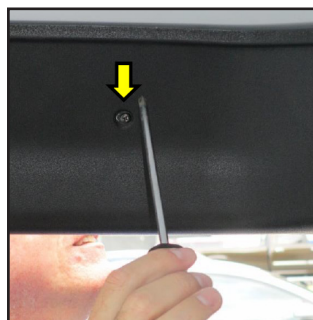
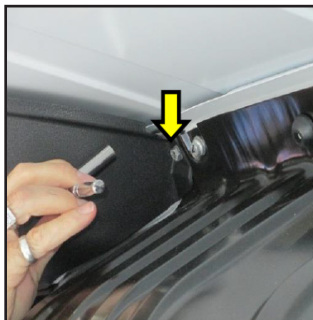

For the black cover, remove the screw on the side and bolt on the front.

NOTE: Do these on both sides of the van.

TOOLS

- Cordless Impact or Ratchet
- Phillips Screw Driver
- 7/16" Socket

2.2.3 Driver and passenger sides preparation.

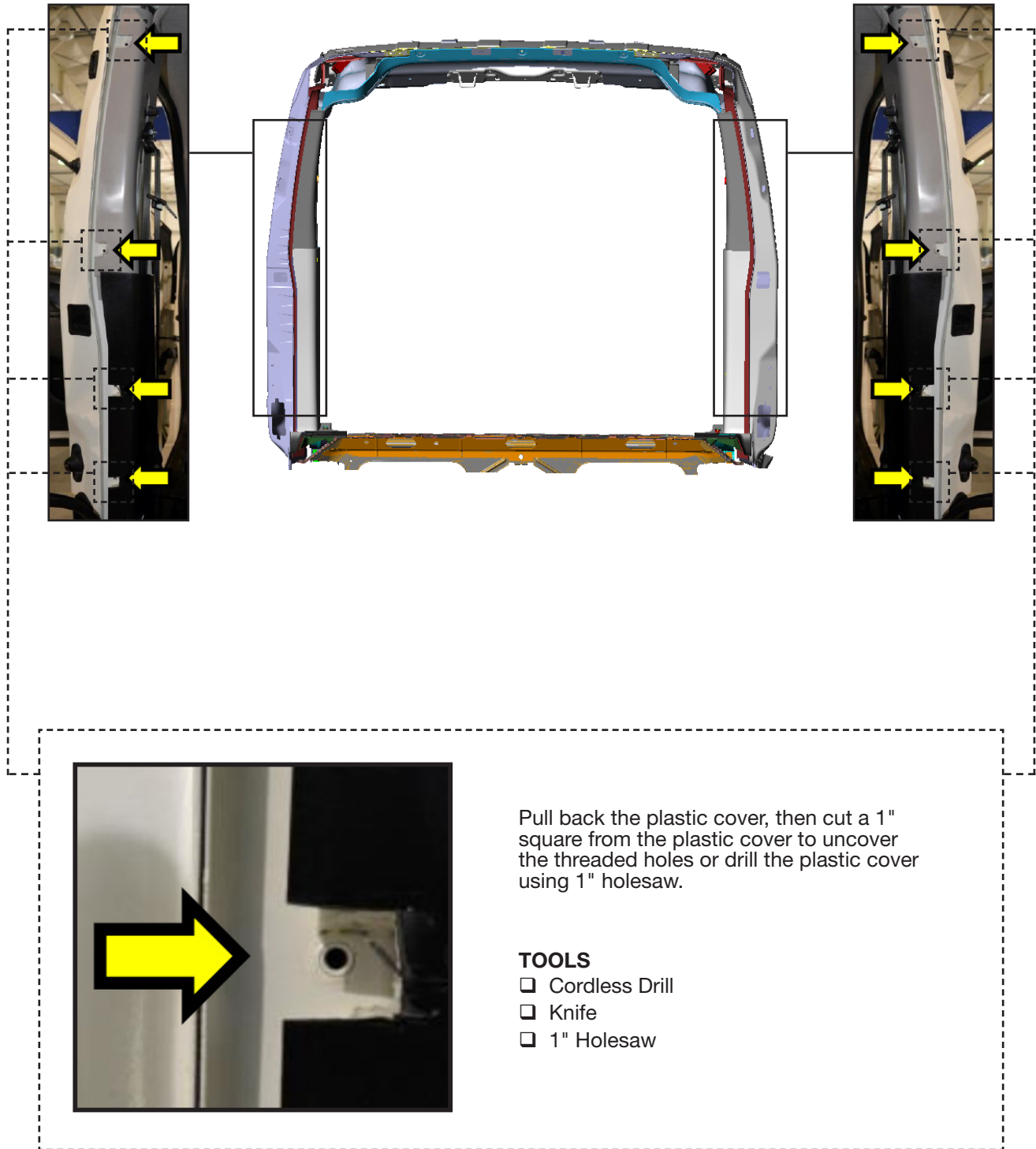

2.2.4 Ceiling and floor preparation.

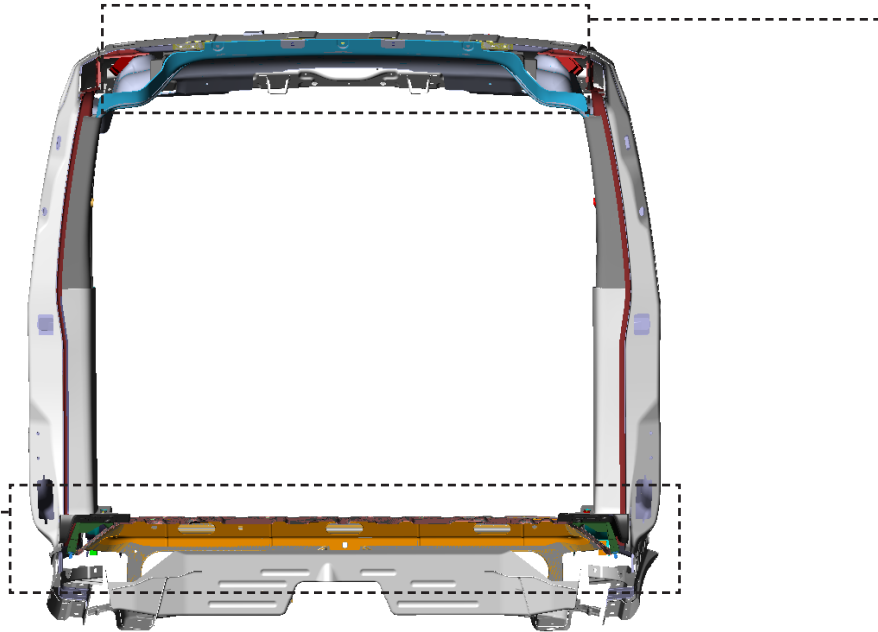

Attach plusnut on these 5 holes.

NOTE: Enlarge these holes if the plusnuts don't fit, using 3/8" drill bit or step drill.

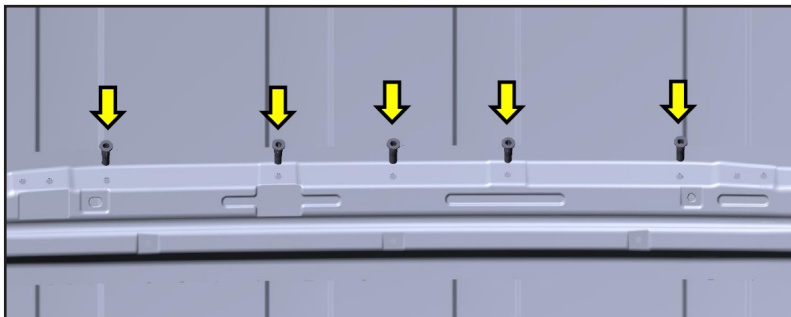

TOOLS

- Plusnut Tool

HARDWARE USED

5x



94-130
Plusnut .250

Remove plastic caps and the two D-rings from vehicle floor, then verify if the threads are in good condition.

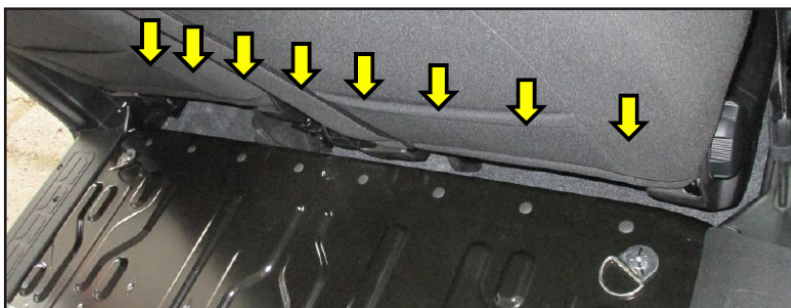

TOOLS

- Cordless Impact
- T40 Torque Bit

PHASE 2 – INSTALLATION

2.3 WIRE MESH PARTITION INSTALLATION

2.3.1 Attach the floor bracket in the van.

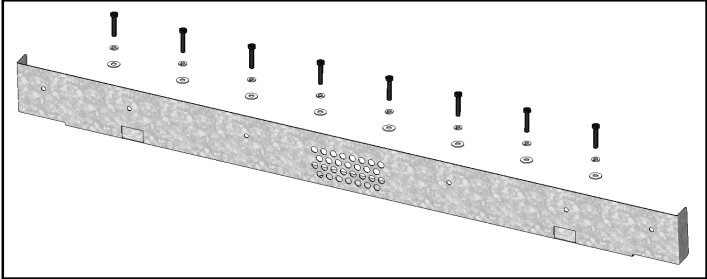

TOOLS

- Cordless Impact
- 13mm Socket

HARDWARE USED

8x



#90-668 Hex Bolt M8 x 40



#98-122 Lock Washer



#98-116 Flat Washer

2.3.2 Lift the assembled partition in the van, then bolt both sides of the partition in the van.

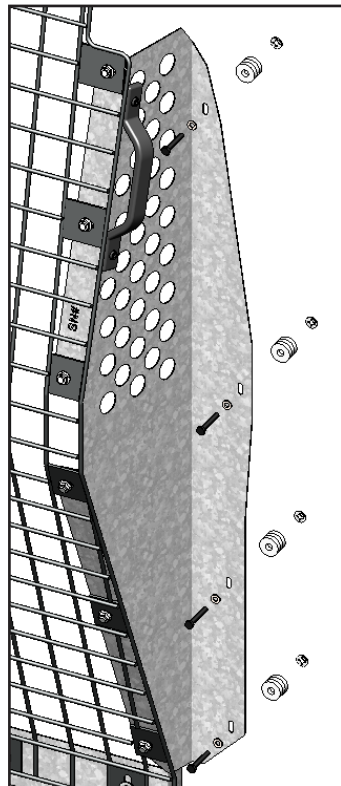
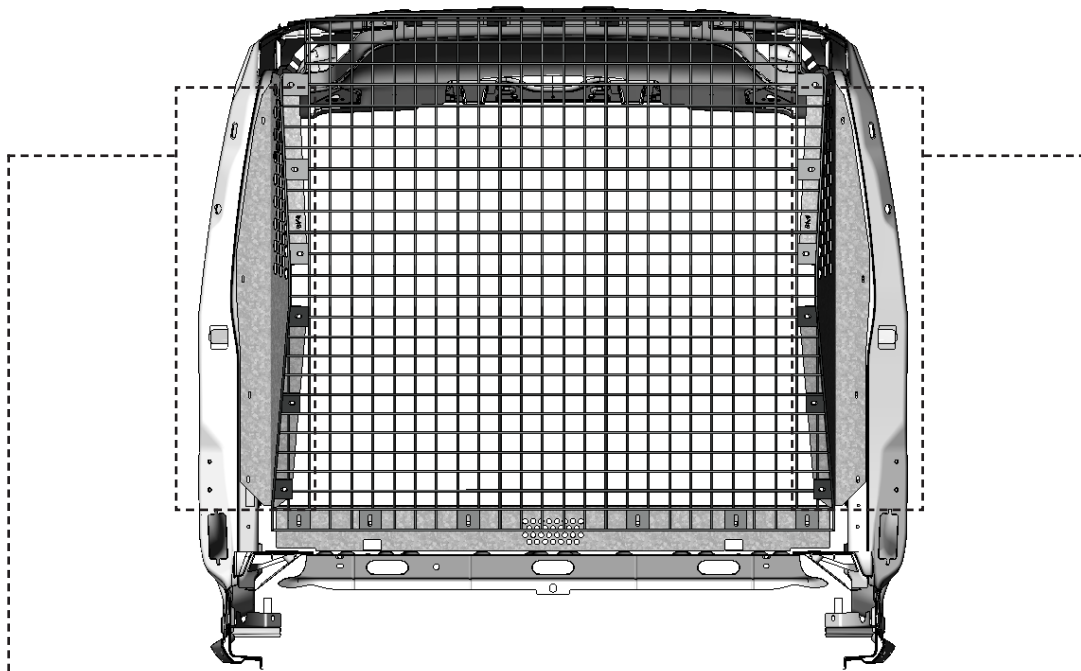





TOOLS

- Cordless Impact
- 10mm Socket

HARDWARE USED

8x

- | | |
|---|----------------------------|
|  | #90-836 Hex Bolt M6 " x 40 |
|  | #98-118 Lock Washer |
|  | #98-112 Flat Washer |
|  | #98-157 Spacers (3) |
|  | #98-158 Retaining Washer |

2.3.3 Attach the top of the partition in the van.

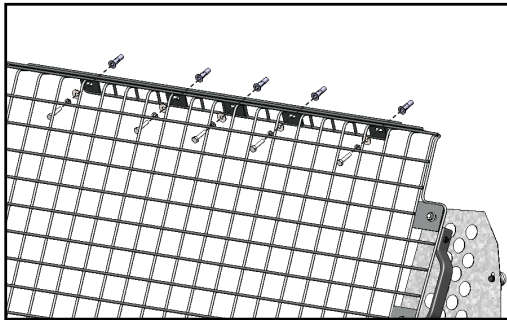
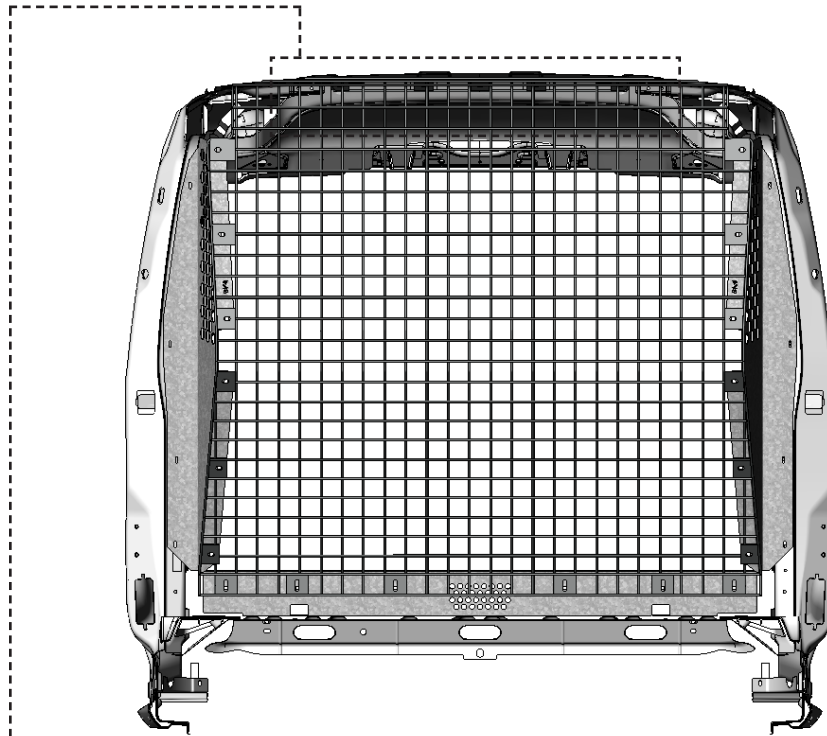

TOOLS

- Cordless Impact
- 7/16" Socket

HARDWARE USED

5x



#90-118 Hex Bolt 1/4" x 1-1/4"



#98-118 Lock Washer



#98-112 Flat Washer

2.3.4 Attach the bottom of the partition to the floor bracket.

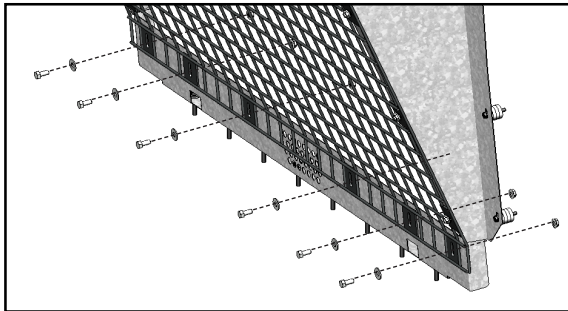
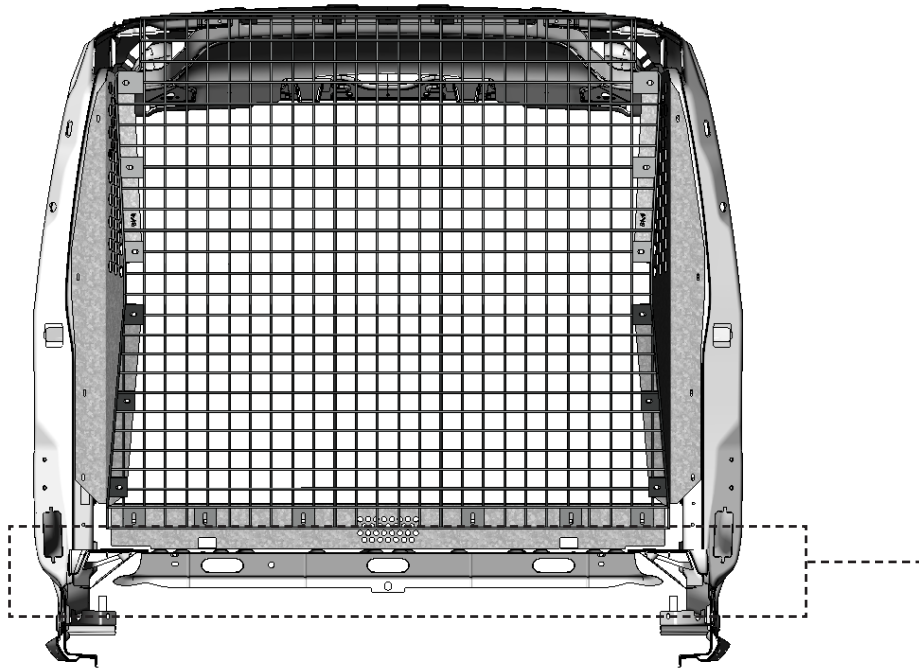



TOOLS

- Cordless Impact
- 1/2" Socket

HARDWARE USED

6x

- | | |
|---|-------------------------------|
|  | #90-204 Hex Bolt 5/16" x 3/4" |
|  | #98-116 Flat Washer |
|  | #94-116 Serrated Nut |

2.3.5 Apply the warning label on the passenger side wing.

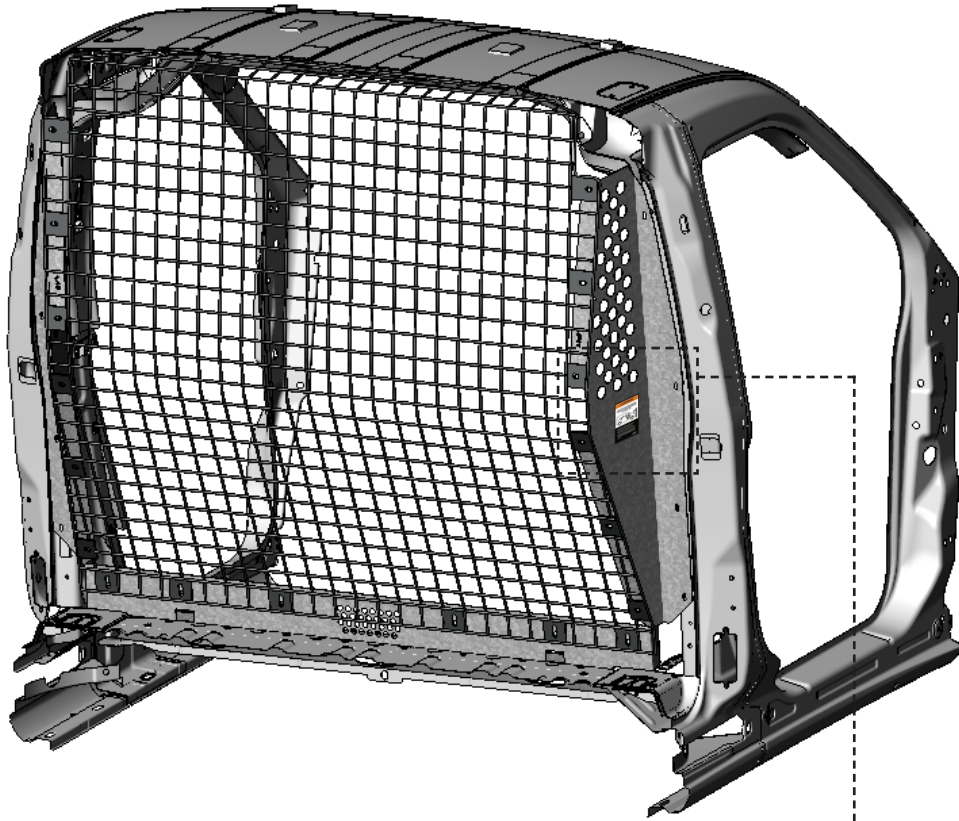

NOTE: Put the warning label in a place where it's easy to see.

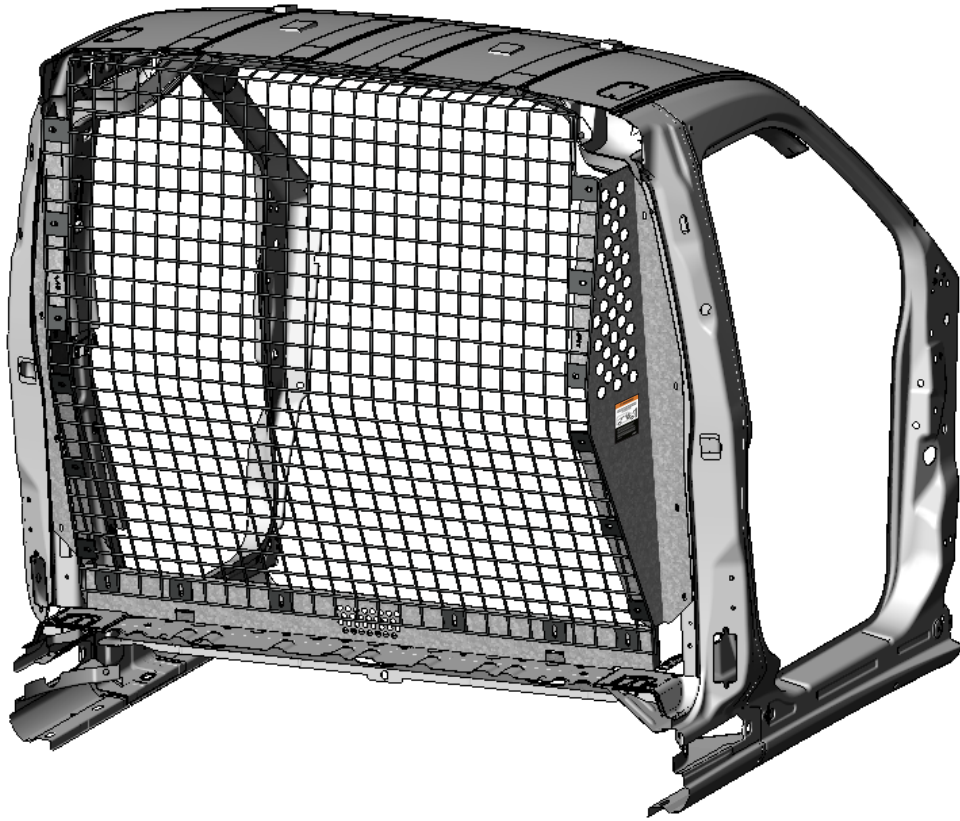

**“Congratulations, you have successfully installed your
Wire Mesh Partition!”**

Thank you for doing business with us.”

