

# INSTALLATION GUIDE

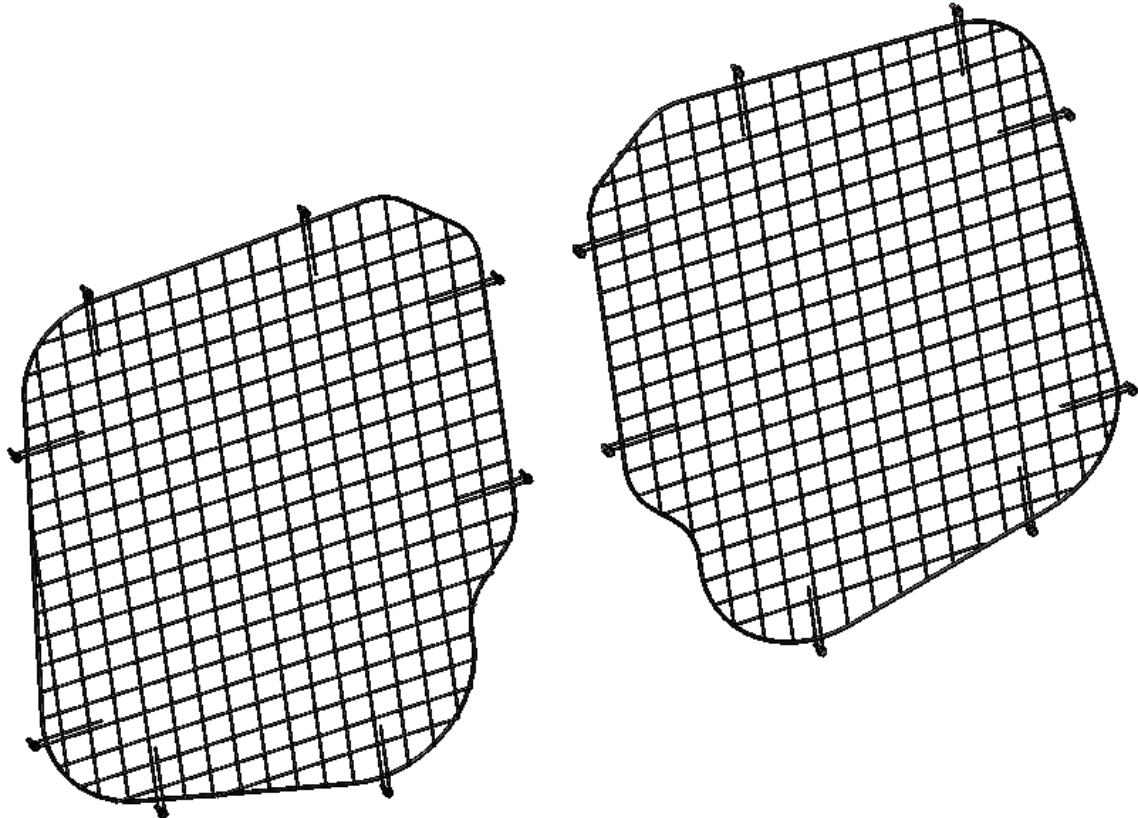

## 6107 Window Grills

Mercedes - Benz ( Rear Window Grills )

# QUICK START GUIDE

## Phase 1 - Assembly

<input type="checkbox"/> 1.1 Setup.....	3 - 4
---	-------

## Phase 2 - Installation

<input type="checkbox"/> 2.1 Window Grill Installation.....	4 - 5
<input type="checkbox"/> 2.2 Window Grill 2019 Sprinter Installation.....	6

# REQUIRED ITEMS

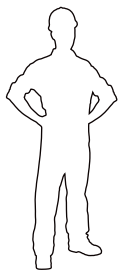

**1**  
**PERSONS**

- Cordless Drill
- 3/8" Driver Bit
- Knife

# PHASE 1 – ASSEMBLY

## 1.1 SETUP

1.1.1 Unpack components; compare with the bill of materials.

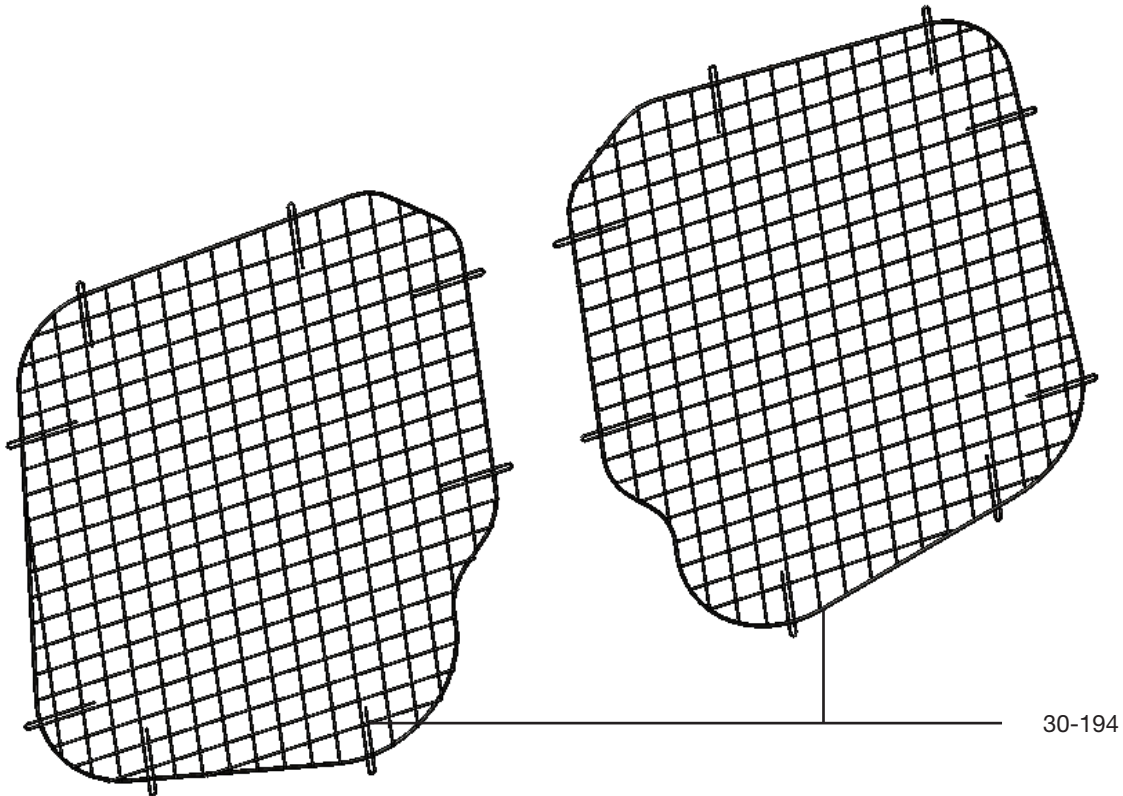

1.1.2 Verify all parts are present.

Item No.	Description	Qty.
30-194	Window Grill	2
96-6004	Customer Installation Fastener Kit	1



16x



# 92-100

Screw HWH  
#14 x 3/4"  
ZINC

16x



#92-100 Screw 3/4"

# PHASE 2 – INSTALLATION

## 2.1 WINDOW GRILL INSTALLATION

2.1.1 Screw one window grill on the driver side rear door.

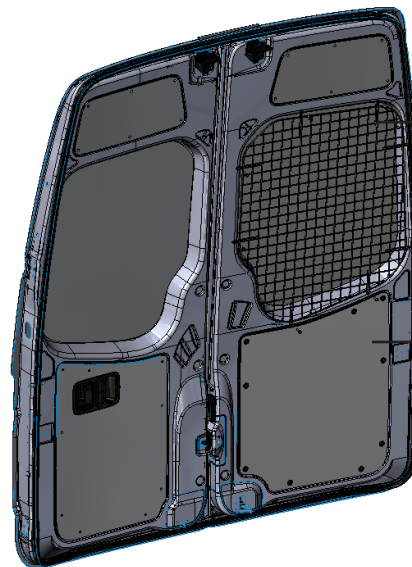

30-194

REAR DOOR

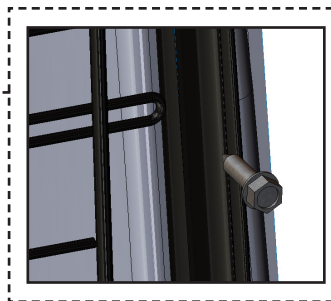
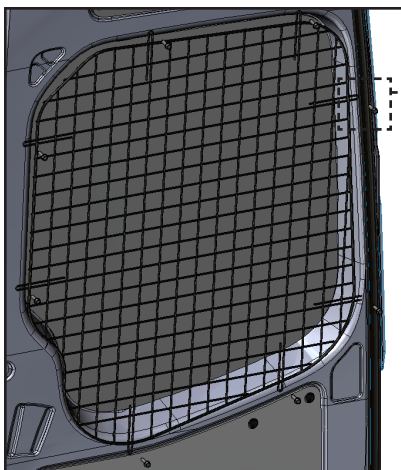

### TOOLS

- Cordless Impact
- 3/8" Driver Bit

### HARDWARE USED

8x



#92-100 Screw 3/4"

2.1.2 Repeat the step 2.2.1 for the other window grill on the passenger side rear door.

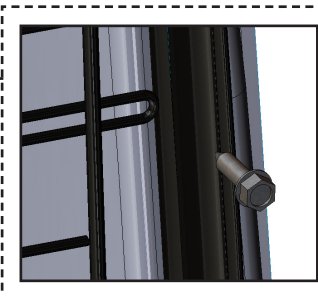
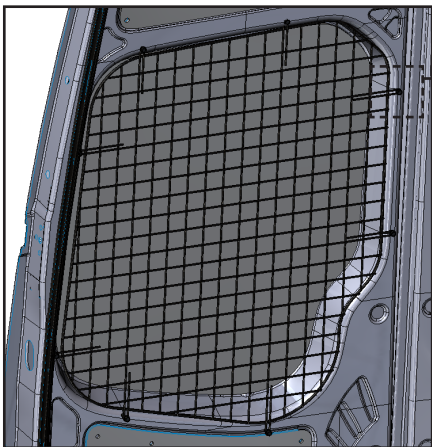
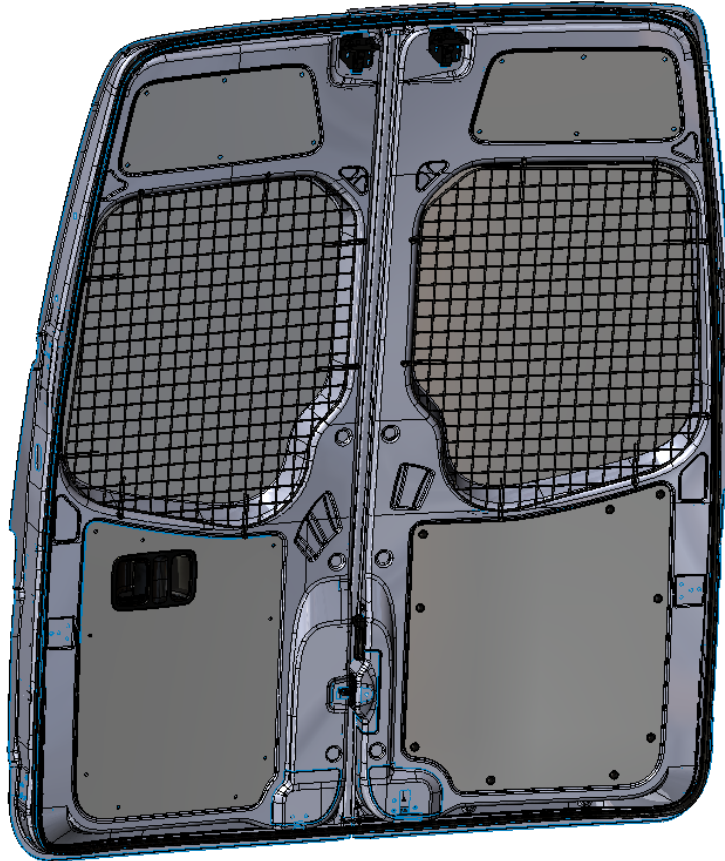

**TOOLS**

- Cordless Impact
- 3/8" Driver Bit

**HARDWARE USED**

**8x**



#92-100 Screw 3/4"

# PHASE 2 – INSTALLATION

## 2.2 WINDOW GRILL 2019 SPRINTER INSTALLATION

2.2.1 Screw one window grill on the driver side rear door, then the other window to passenger side rear door.

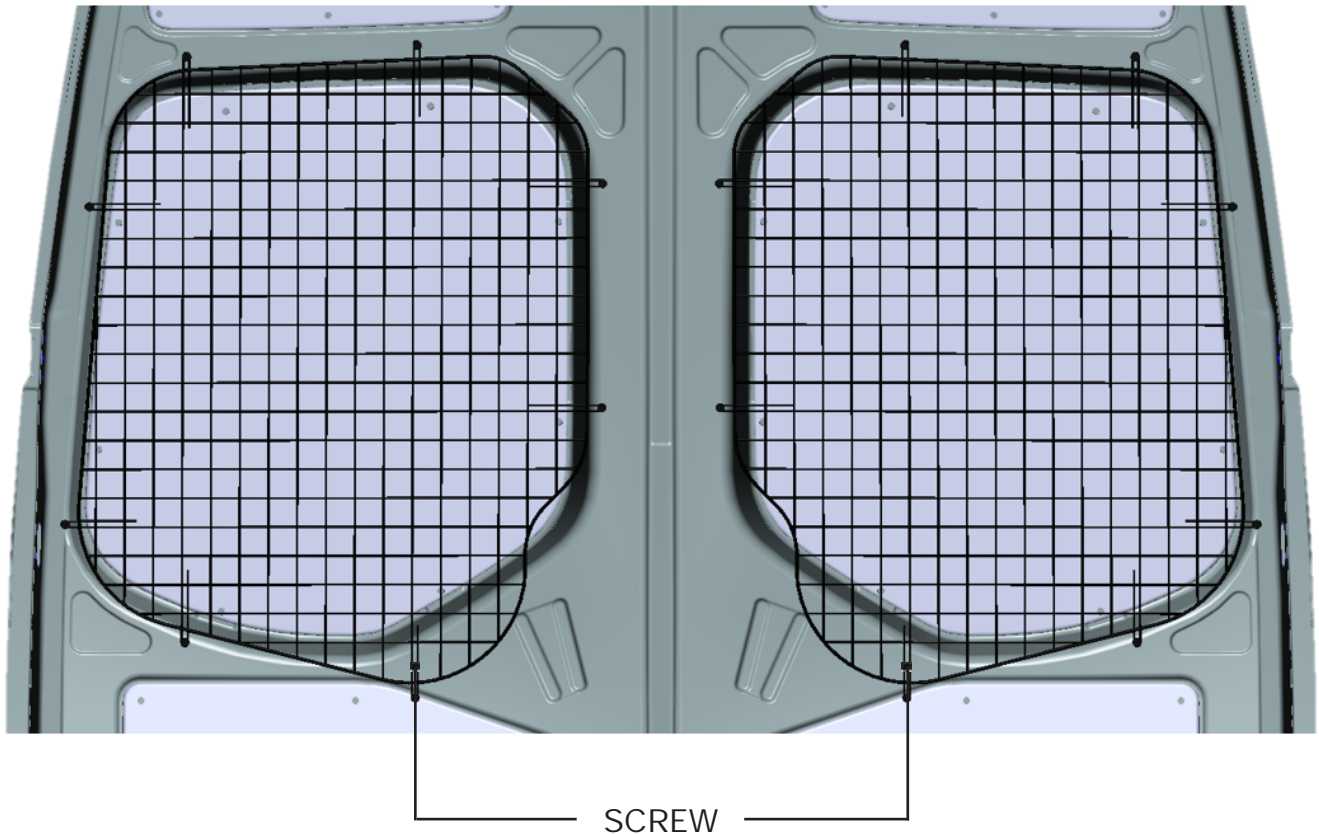

**TOOLS**

- ☐ Cordless Impact
- ☐ 3/8" Driver Bit

**HARDWARE USED**

**8x**

	#92-100 Screw 3/4"
---	--------------------

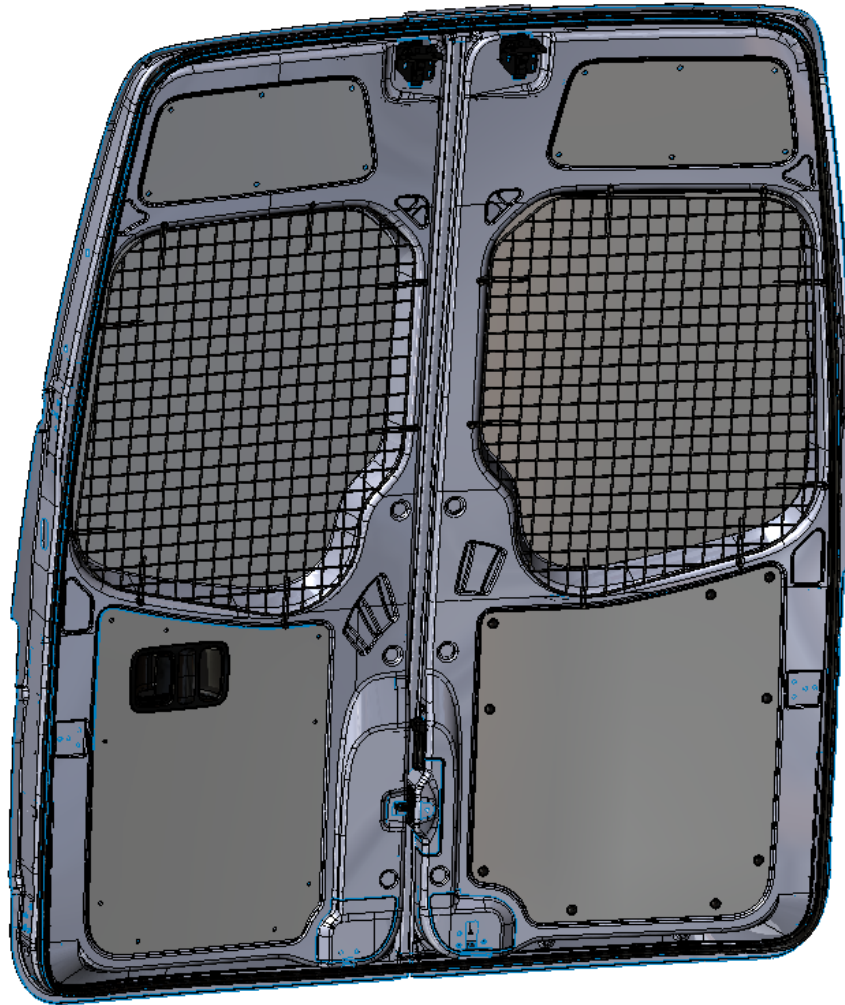

**“You have successfully installed your  
6107 Window Grill**

**Thank you for doing business with us.”**

For any feedback or suggestions you may have, please contact: [cs@rangerdesign.com](mailto:cs@rangerdesign.com)

