

ITEM NO.	NUMBER	DESCRIPTION	QTY.
1	30-087	WINDOW GRILL - REAR, PASSENGER DOOR, MERCEDES METRIS	1
2	30-088	WINDOW GRILL - REAR, DRIVER DOOR, MERCEDES METRIS	1
3	92-000	SCREW - PHIL. TRUSS HEAD, SHEET METAL, TYPE AB, #12 x 0.75, ZINC	12

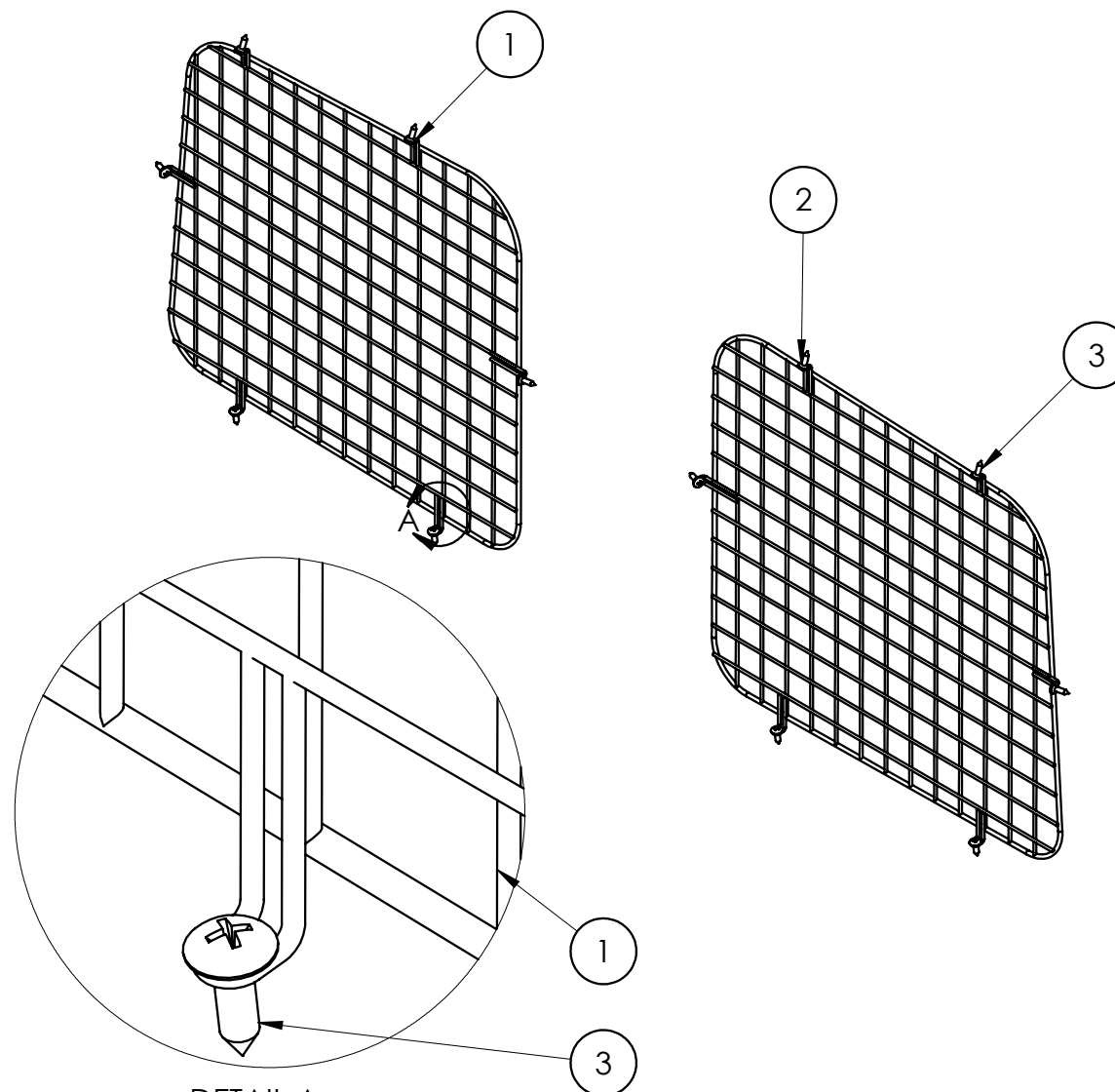
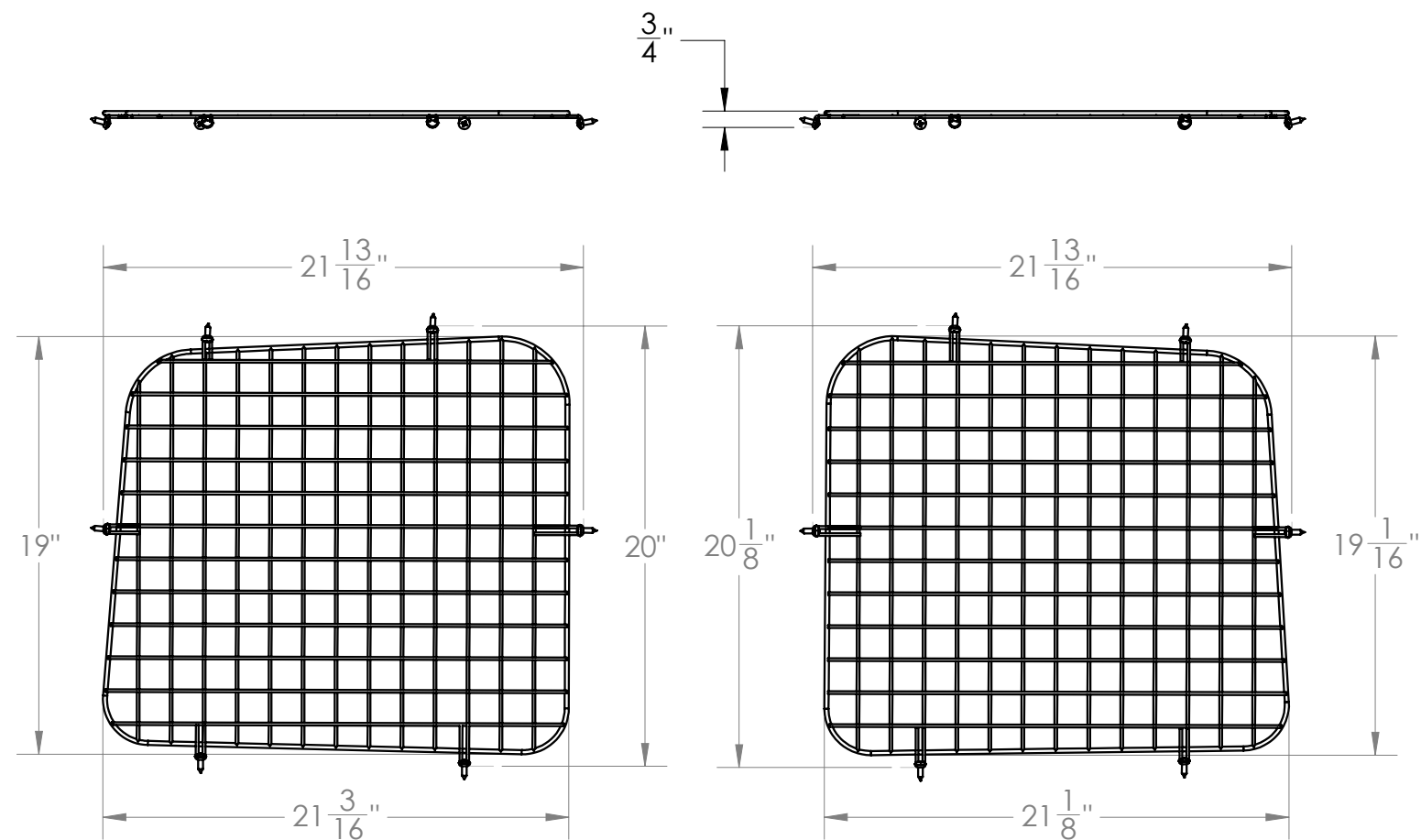

NOTE:
 1 PARTS TO BE PACKAGED IN A BOX AND PROPERLY PROTECTED.
 2 FASTENERS TO BE PACKAGED IN A SINGLE BAG AND ADDED IN THE BOX.
 3 BOXES WILL BE STACKED AS TO PREVENT DAMAGE DURING TRANSPORTATION.
 4 CUSTOMER INSTALLATION FASTENER KIT **96-6000**.

3D MODEL VERIFIED BY: CR 07-29-2015		THE INFORMATION CONTAINED IN THIS DRAWING IS THE SOLE PROPERTY OF RANGER DESIGN INC. ANY REPRODUCTION IN PART OR AS A WHOLE WITHOUT THE WRITTEN PERMISSION OF RANGER DESIGN INC IS PROHIBITED. MM-DD-YYYY 02-12-2015 02-26-2015 07-29-2015 07-29-2015	MATERIAL:		RANGER DESIGN Ranger Design inc. 19160 Cruickshank, Baie d'Urfé, Québec, Canada H9X 3P1
3D MODEL APPROVED BY: CR 07-29-2015			FINISH:		
DESIGNED BY: IP			UNLESS OTHERWISE SPECIFIED DIMENSIONS ARE IN INCHS		
DRAWN BY: IP			GENERAL TOLERANCES FRACTIONAL: ±1/32 DECIMAL: 0.000 = ±0.005 0.00 = ±0.01 0.0 = ±0.05 ANGULAR: ±0.1° HOLE DIAMETER: ±0.005		
VERIFIED BY: CR		BENDING TOLERANCES BEND: ±0.010 ANGULAR: ±0.5° HEM: ±0.015		TITLE: WINDOW GRILL - SET, REAR DOORS, MERCEDES METRIS	
APPROVED BY: CR		THIRD ANGLE PROJECTION		SIZE B	DWG. NO. 6126
REVISIONS				E.W.: 4.7	SCALE: 1:8
				REV A	
				SHEET 1 OF 1	

ZONE	REV	DESCRIPTION	DATE (MM-DD-YYYY)	BY
	A	RELEASED FOR PRODUCTION: ECN 2505	07-29-2015	CR