

INSTALLATION GUIDE

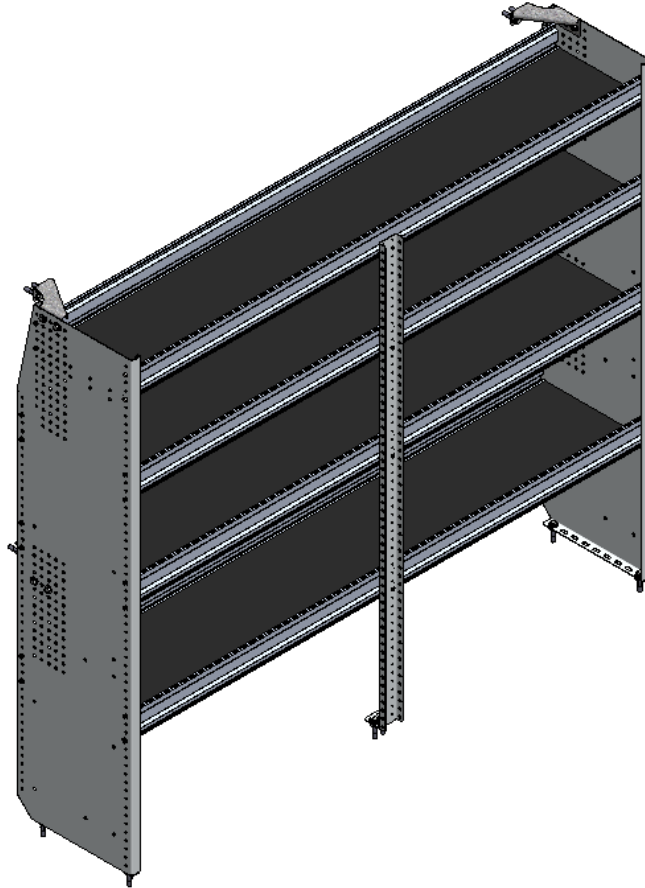

N5-RA72-4 Shelving (ALUMINUM)

Transit High Roof & Medium Roof

Promaster Standard Roof & High Roof

Nissan NV High Roof

Sprinter RWB, LWB, XWB

Box Truck / Trailer



QUICK START GUIDE

Phase 1 - Assembly

- 1.1 Setup..... 3 - 4
- 1.2 Shelf Assembly..... 5 - 6

Phase 2 - Installation

- 2.1 Attach Wall Brackets To The End Panels..... 7
- 2.2 Mark Holes For Plus Nuts..... 8
- 2.3 Attach Plus Nut..... 9 - 10
- 2.4 Attach Shelf Unit To the Floor..... 11 - 12
- 2.5 Attach Wall Brackets..... 13 - 14

REQUIRED ITEMS

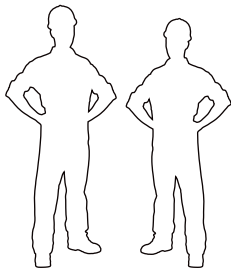

2
PERSONS

- Cordless Impact
- Cordless Drill
- Tape Measure
- Marker
- 1/2" Socket
- 1/2" Drill Bit w/ Drill Collar (Set at 1/2")
- 3/8" Driver Bit
- Knife
- Plusnut Tool / Plusnut Gun (5/16")

PHASE 1 – ASSEMBLY

1.1 SETUP

1.1.1 Unpack components; compare with the bill of materials.

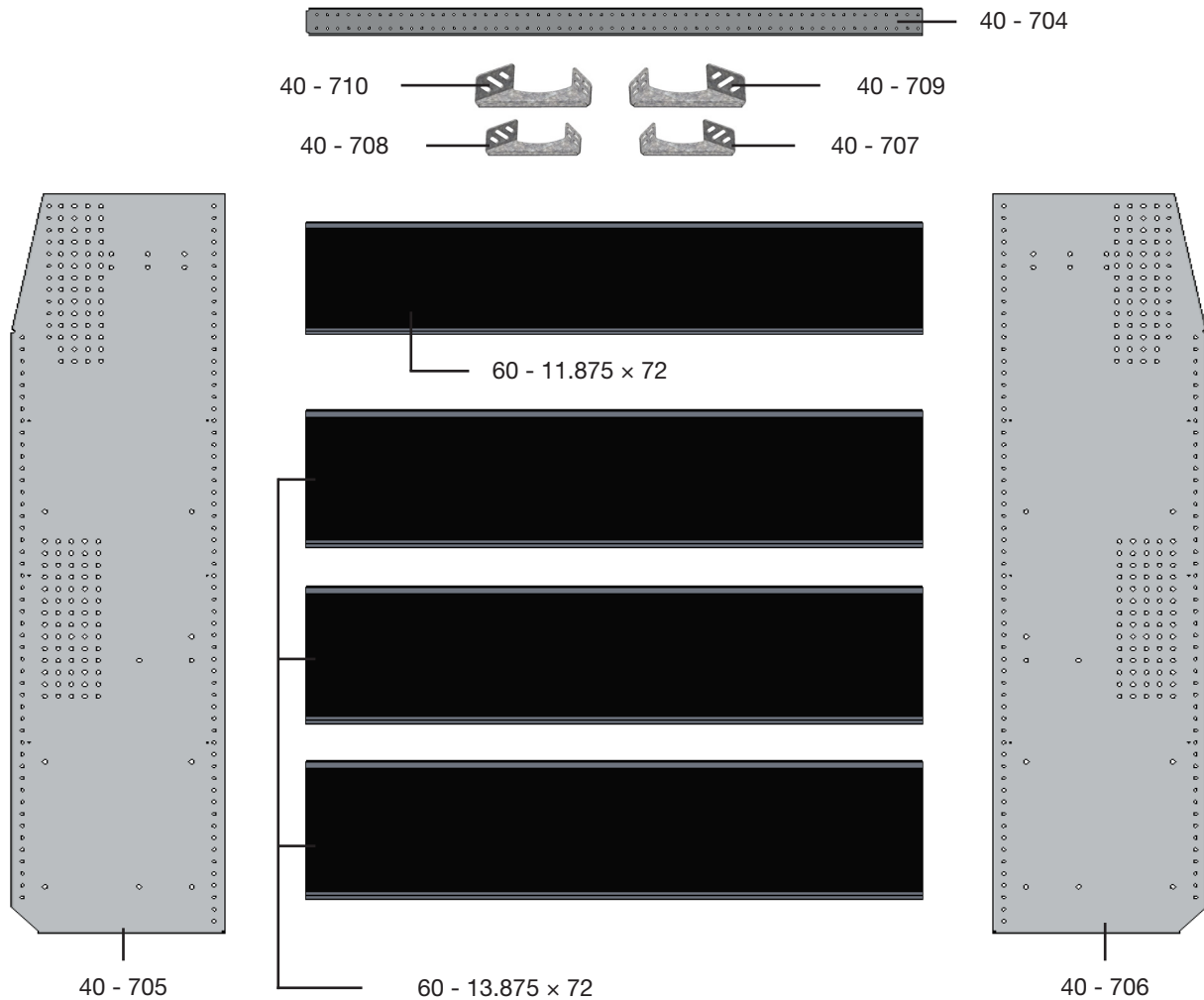

1.1.2 Verify all parts are present.

BILL OF MATERIALS

Item No.	Description	Qty.
40 - 704	Center Post	1
40 - 707	Short Corner Bracket (Left)	1
40 - 708	Short Corner Bracket (Right)	1
40 - 709	Long Corner Bracket (Left)	1
40 - 710	Long Corner Bracket (Right)	1
40 - 705	End Panel (Left)	1
40 - 706	End Panel (Right)	1
60 - 11.875 x 72	Shelf Tray, Black Plywood, Usable 12" x 72"	1
60 - 13.875 x 72	Shelf Tray, Black Plywood, Usable 14" x 72"	3
94 - 4026	Assembly Fastener Kit	1

1.1.3 Fastener kits.

94 - 4026 Fastener Kit

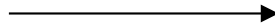

Fastener Assembly

- 8x  # 90-204 Hex Bolt 5/16"-18 x 3/4" GR-5 ZINC
- 8x  # 92-200 Screw HFH #10 - 16 x 3/4" ZINC
- 32x  # 92-102 Screw HWH #14 x 1" ZINC
- 8x  # 94-116 Serrated Nut 5/16"-18 ZINC
- 8x  # 98-116 Flat Washer 5/16" - 18 x 1" ZINC

8x



- #90-204 Hex Bolt 5/16" x 3/4"
- #98-116 Flat Washer
- #94-116 Serrated Nut

8x



- #92-200 Screw #10 - 16 x 3/4"

32x



- #92-102 Screw #14 x 1"

96 - 4026 Fastener Kit



Fastener Assembly

- 14x  # 90-212 Hex Bolt 5/16"-18 x 1-1/4" GR-5 ZINC
- 14x  # 94-132 Plusnut
- 14x  # 98-116 Flat Washer 5/16", O.D. 7/8" ZINC
- 14x  # 98-122 Lock Washer 5/16" ZINC
- 6x  # 98-157 Spacer 0.375" ID, x 1.0" OD x 0.25" LONG NYLON

8x



- #90-212 Hex Bolt 5/16" x 1-1/4"
- #98-122 Lock Washer
- #98-116 Flat Washer
- #94-132 5/16" Plusnut

6x



- #90-212 Hex Bolt 5/16" x 1-1/4"
- #98-122 Lock Washer
- #98-116 Flat Washer
- #98-157 Spacers (QTY = GAP BETWEEN FLOOR AND END PANEL)
- #94-132 5/16" Plusnut

PHASE 1 – ASSEMBLY

1.2 SHELF ASSEMBLY

1.2.1 Attach both panels to the shelf trays.

NOTE: You can adjust the bottom shelf location to maximize or minimize your space over the wheel.

IMPORTANT: Always handle panels on a smooth, protected and clean surface to avoid unnecessary scratching.

TIPS: Shelf tray position guide.

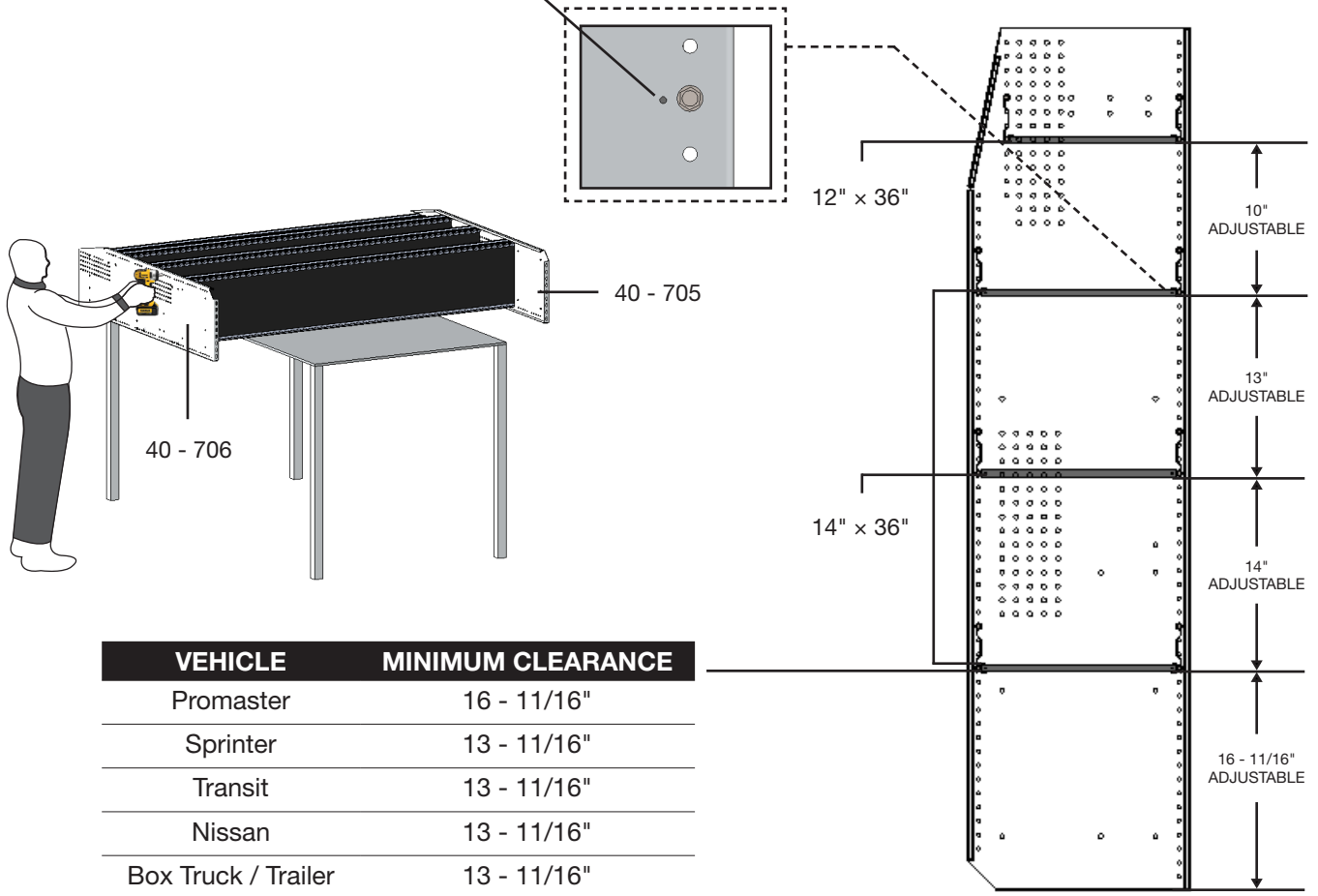

VEHICLE	MINIMUM CLEARANCE
Promaster	16 - 11/16"
Sprinter	13 - 11/16"
Transit	13 - 11/16"
Nissan	13 - 11/16"
Box Truck / Trailer	13 - 11/16"

TOOLS

- ☐ Cordless Impact
- ☐ 3/8" Driver Bit

HARDWARE USED

32x

#92-102 Screw #14 x 1"

1.2.2 Attach the center post to the center front face of the shelf.

IMPORTANT: The center post should be attached in the center of the shelf.

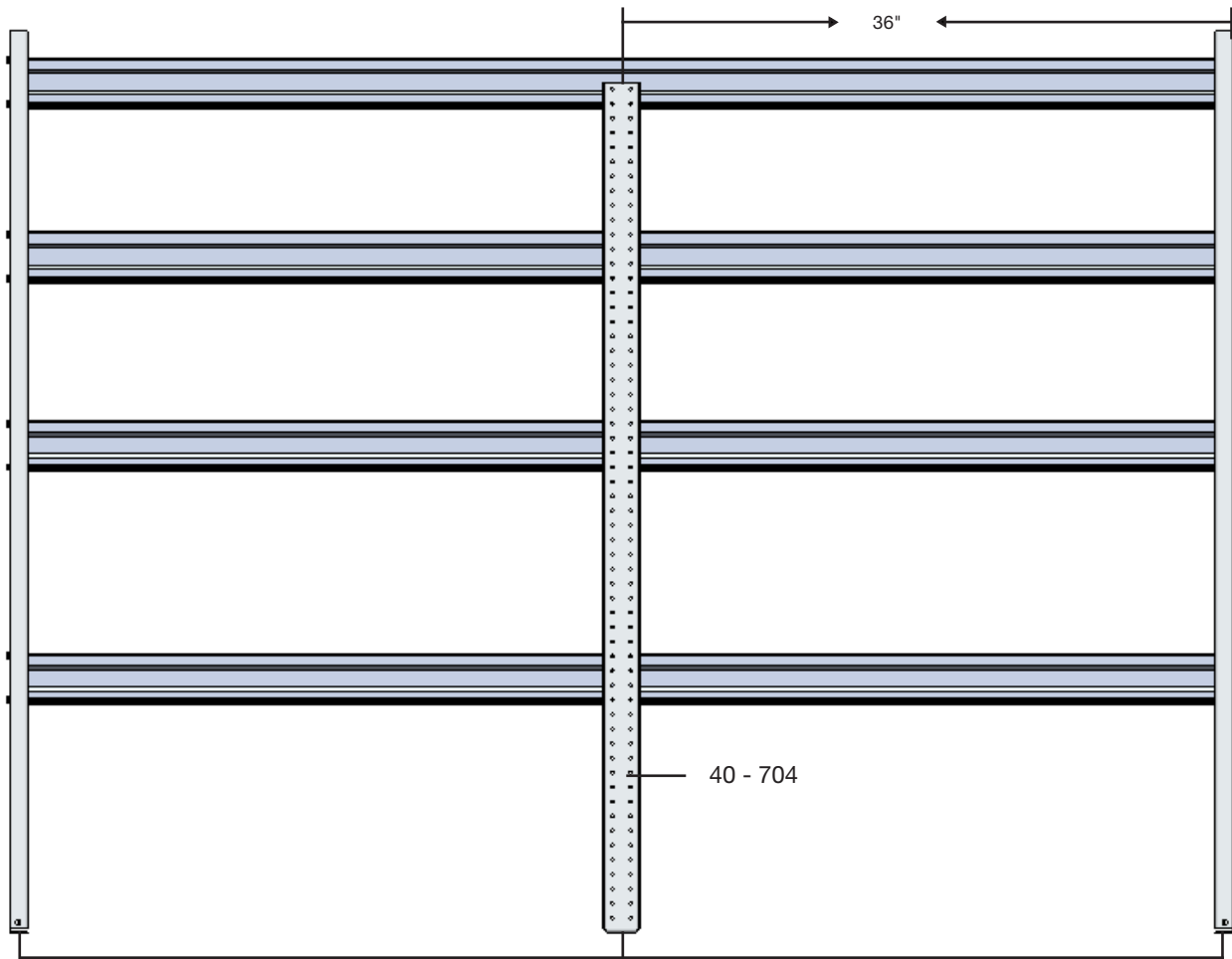

NOTE: The bottom flange of the center post need to be flush with the bottom of the end panel.

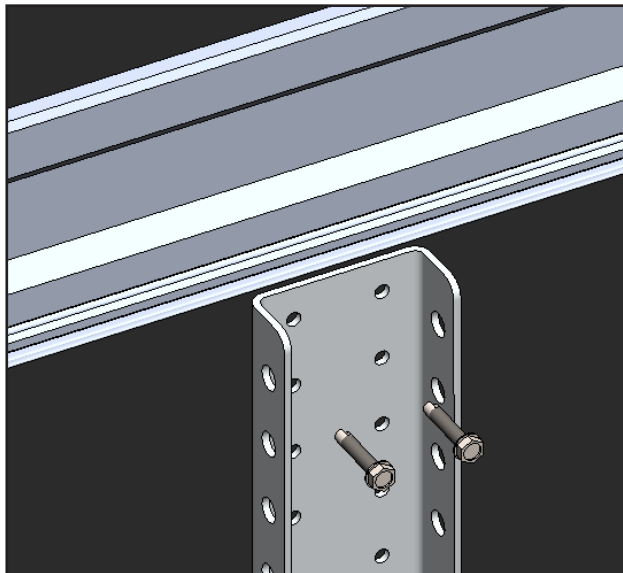

TOOLS

- Cordless Impact
- 3/8" Driver Bit

HARDWARE USED

8x

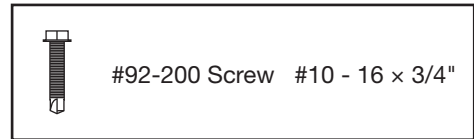

PHASE 2 – INSTALLATION

2.1 ATTACH WALL BRACKETS TO THE END PANELS

IMPORTANT: For all **Box Trucks**, make sure that the shelving is securely fastened to the structure of the truck.

- 2.1.1**
- Lift the assembled shelf to the vehicle, then put it in place.
 - Attach the short and long brackets to the panels aligning the brackets to the horizontal rim of the vehicle.

NOTE: Handle with care.

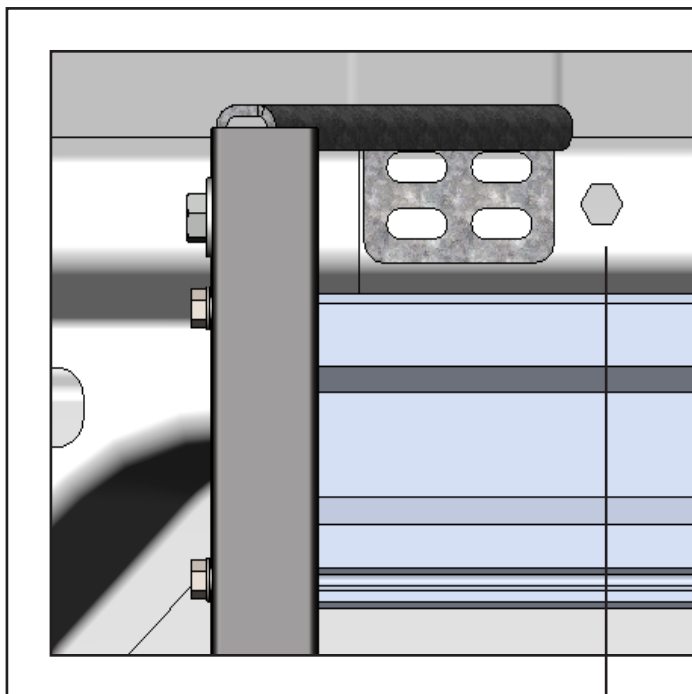
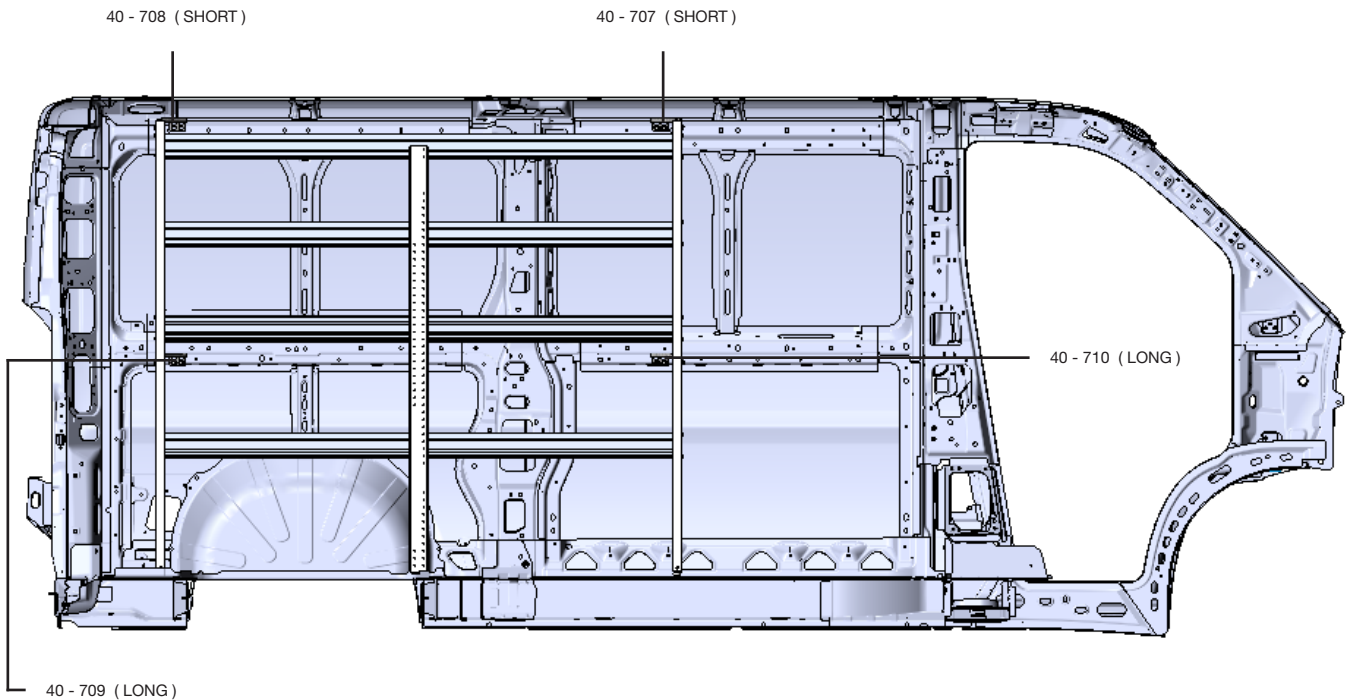

Attach the short and long brackets to the panels aligning the brackets to the horizontal rim of the vehicle.



NOTE: You can install the brackets inside or outside the panel.

TOOLS

- Cordless Impact
- 1/2" Socket

HARDWARE USED

8x HAND-TIGHTEN THE BOLTS

- | | |
|---|-------------------------------|
|  | #90-204 Hex Bolt 5/16" x 3/4" |
|  | #98-116 Flat Washer |
|  | #94-116 Serrated Nut |

HORIZONTAL RIM

PHASE 2 – INSTALLATION

2.2 MARK HOLES FOR PLUS NUTS

2.2.1 After attaching the brackets mark the holes on the brackets, end panels and center post to the vehicle.

NOTE: The distance between the two holes should be no less than 1", to avoid plus nut overlap

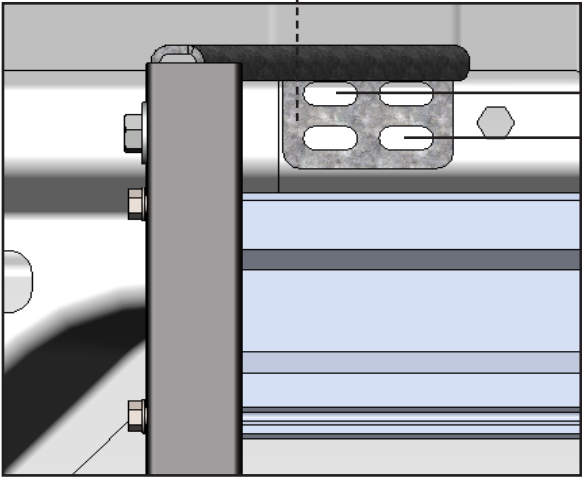
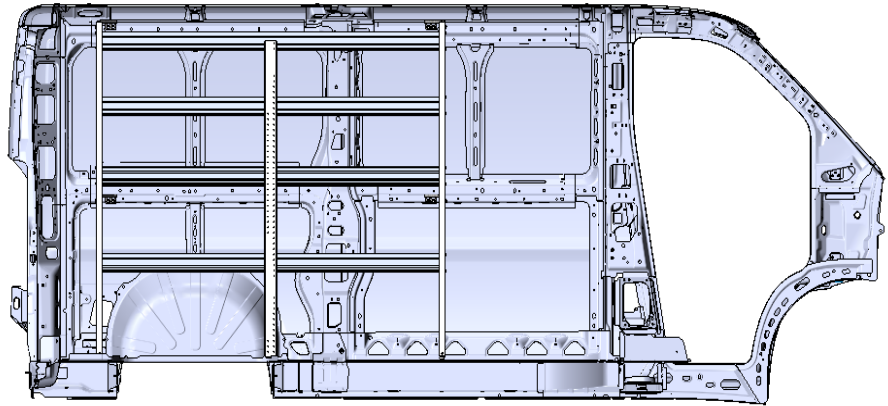
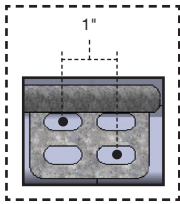

Mark 2 holes of the short and long brackets on the vehicle horizontal rim.

NOTE: If you are using Ranger wall kits, please go to **PAGE 14**.

TOOLS
 Marker

MARK

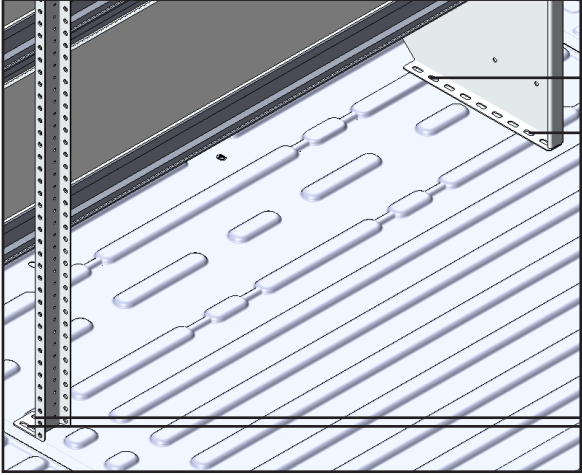

Mark 2 holes of each end panel and mark also the 2 holes of the center post on the vehicle floor.

NOTE: If you are using Ranger floor, please go to **PAGE 12**.

TOOLS
 Marker

MARK

PHASE 2 – INSTALLATION

2.3 ATTACH PLUS NUTS

- 2.3.1**
- Lift the assembled shelf on the side.
 - Drill all the marks using 1/2" drill bit w/ drill collar, then attach plus nuts to the holes.

NOTE: Use 1/2" drill bit with drill collar to stop drill at 1/2" depth.

WARNING: Before drilling, ensure that you will not hit any critical parts of the vehicle like the **Gas tank**, **Wiring Harness** and **Hose**.

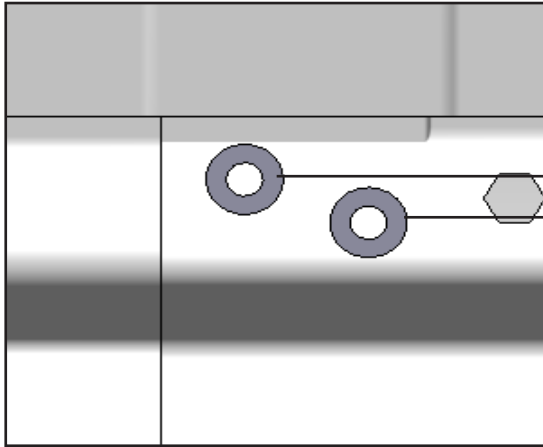
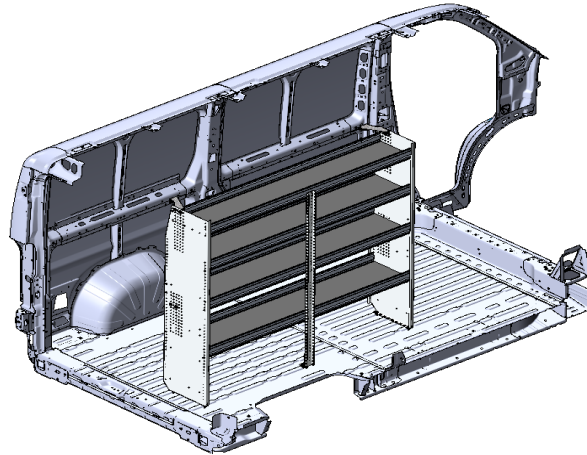

PLUSNUT

Drill all the marks then, attach plus nuts to the holes.

TOOLS

- Cordless Drill
- 1/2" Drill Bit w/ Drill Collar (Set at 1/2")
- Plus Nut Tool (5/16")

HARDWARE USED

14x



#94-132 Plus Nut

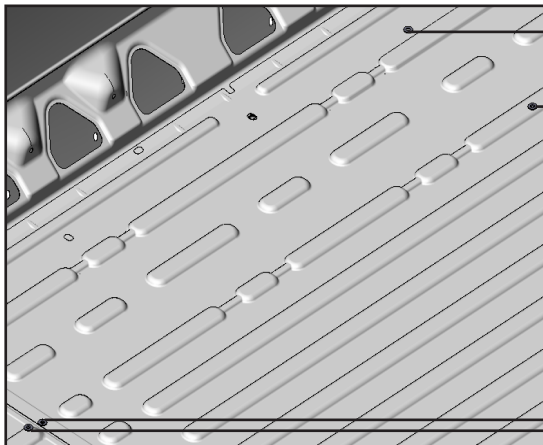

DRILL COLLAR
(SET AT 1/2")

2.3.2 How to attach plus nut.

• USING PLUSNUT GUN

STEP: Put the plusnut on the plusnut gun, then attach the plus nut in the hole by turning the gun forward until the plus nut locks, then remove the gun by turning in reverse.

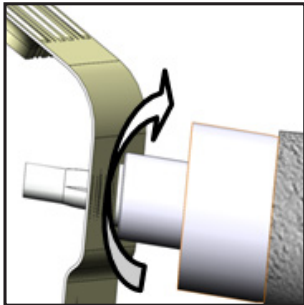

FORWARD

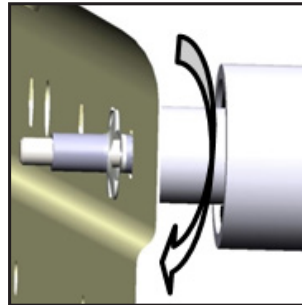

REVERSE

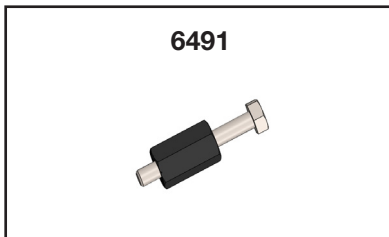

• USING THE 6491 PLUSNUT TOOL

NOTE: The hardware used for the 6490 plusnut tool is not included in the fastener bag. The 6490 plusnut tool can be ordered separately upon demand at no charge.



6491

HARDWARE USED

-  Flat washer 5/16"
-  Flat washer 5/16" BS x 7/8" OD

TOOLS

- Cordless Impact
- 1/2" Socket
- 9/16" Wrench

STEP 1:

Assemble the 6491 plusnut tool with the hardware needed, plus nut and the 9/16" wrench as shown.



STEP 2:

Attach the plus nut in the hole by turning the bolt forward using an impact with a 1/2" socket until the plusnut locks, then remove the bolt by turning the impact in reverse.

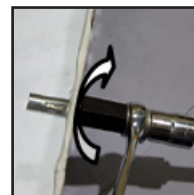

FORWARD



REVERSE

PHASE 2 – INSTALLATION

2.4 ATTACH SHELF UNIT TO THE FLOOR

WITHOUT RANGER FLOOR

2.4.1 Put the assembled shelf back in place aligning the holes to the plusnuts, then install the end panels and center post to the plus nuts.

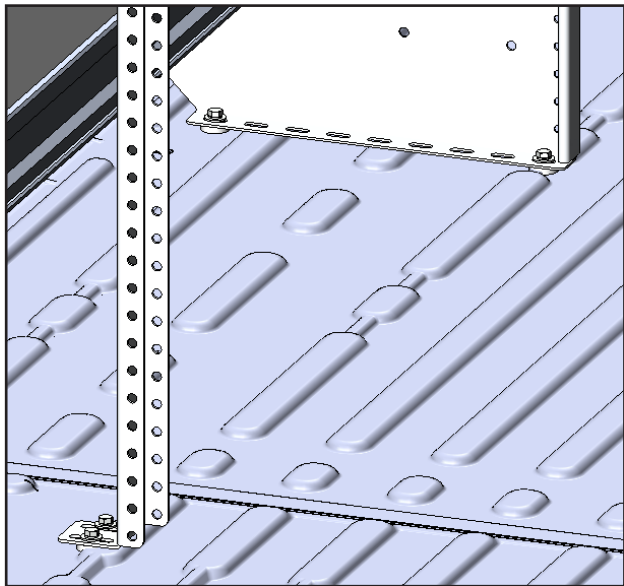
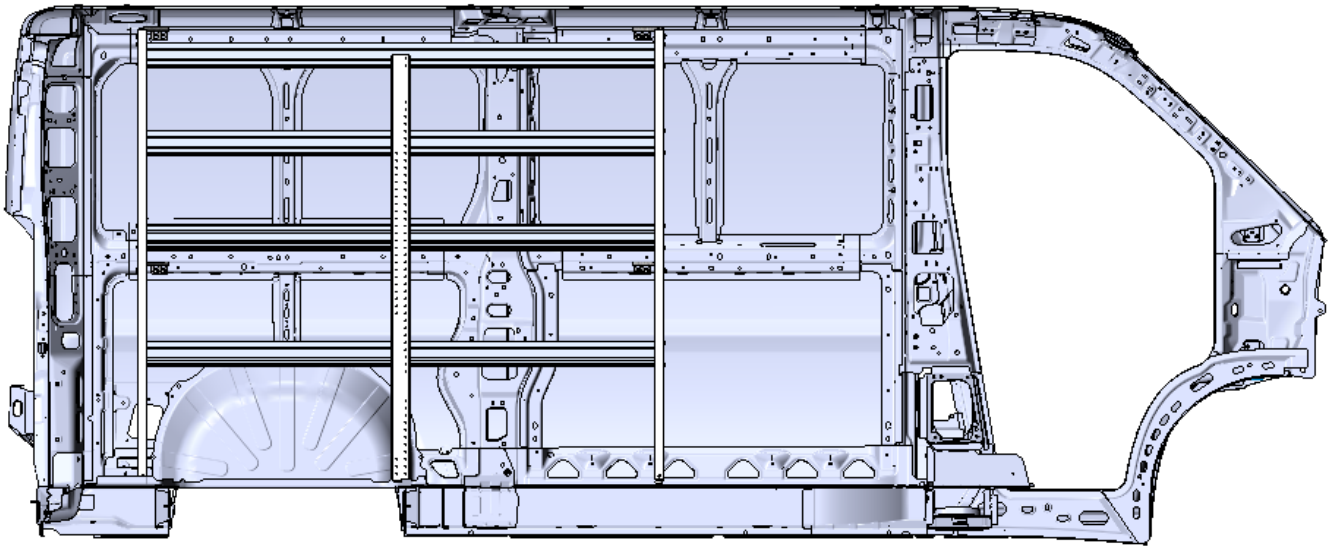





TOOLS

- Cordless Impact
- 1/2" Socket

HARDWARE USED

6x

-  #90-212 Hex Bolt 5/16" x 1-1/4"
-  #98-122 Lock Washer
-  #98-116 Flat Washer
-  #98-157 Spacers
(QTY = GAP BETWEEN FLOOR AND END PANEL)
-  #94-132 5/16" Plusnut

MOST VEHICLE USE 1 SPACER WHEN NOT OVER RIBS

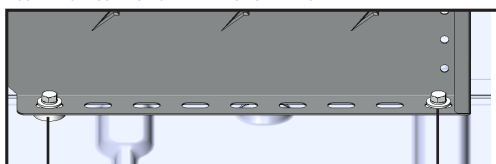

W/ Spacer

W/O Spacer

WITH RANGER FLOOR

- 2.4.2 • Lift the shelving unit inside the van, then put it in place.
• Install the shelving unit to the floor mounting track by sliding bolts in the mounting tracks, and putting screw in the last rear slot of the end panels of the shelving unit.

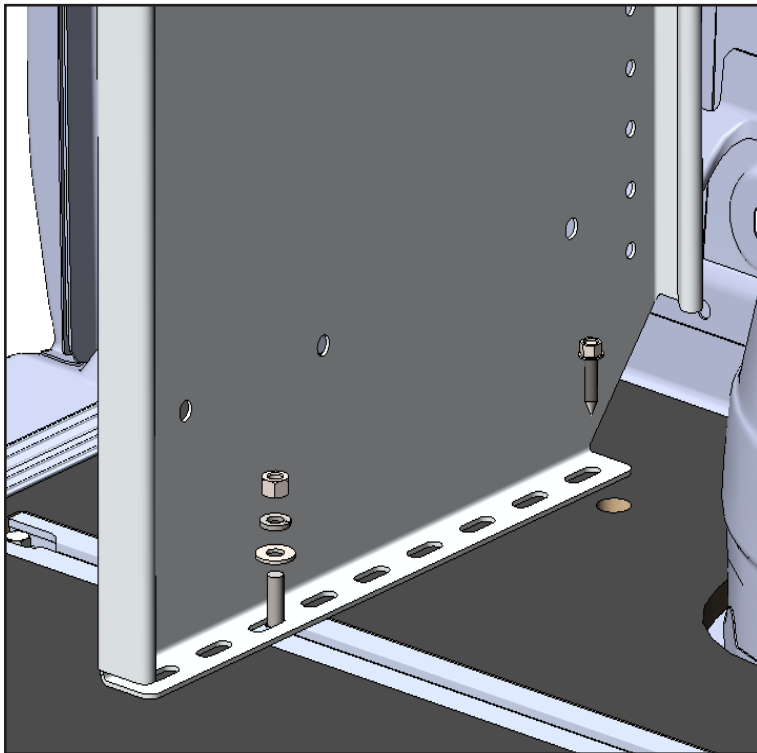
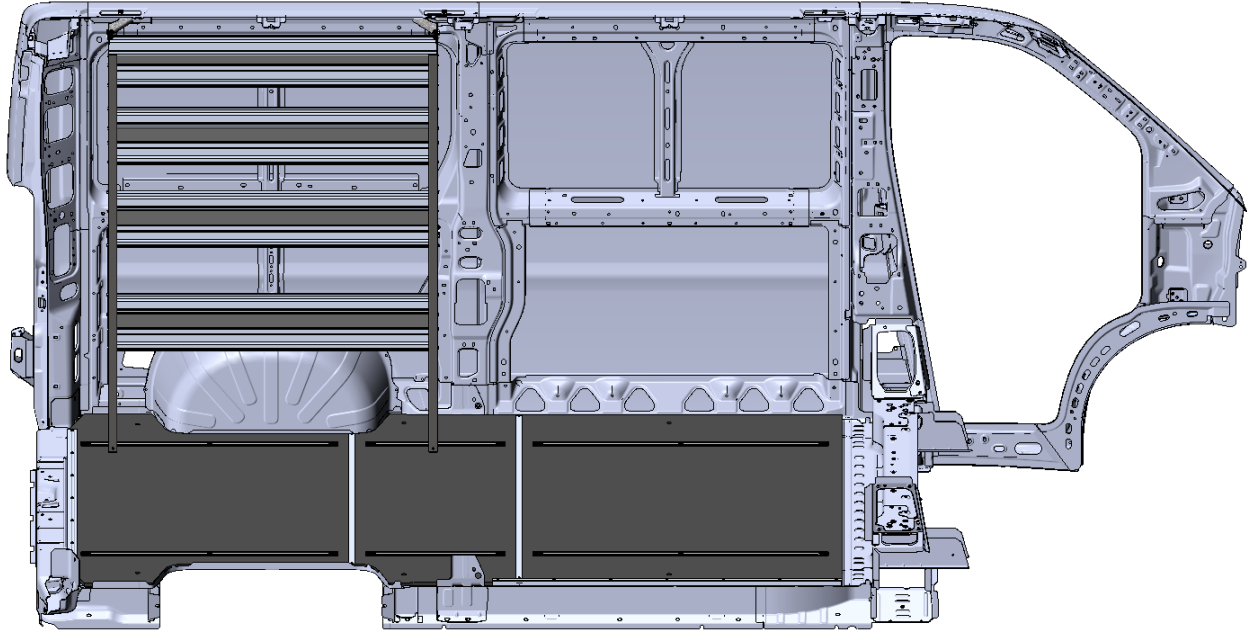

TOOLS

- Cordless Impact
- 3/8" Driver Bit
- 1/2" Socket

HARDWARE USED

2x FLOOR FASTENER KIT



#92-102 Screw 1"

HARDWARE USED

2x FLOOR FASTENER KIT



#90-490 Carriage Bolt 5/16" x 1"



#98-116 Lock Washer



#98-122 Flat Washer



#94-104 Hex Nut

PHASE 2 – INSTALLATION

2.5 ATTACH WALL BRACKETS

WITHOUT RANGER WALL KITS

2.5.1 Aligned the wall brackets to the plus nuts, then install the wall brackets to the wall.

NOTE: Tightened the bolts that used to attached the wall bracket to the wall or wall kits 1st before the bolts that used to attached the wall bracket to the end panel.

IMPORTANT: After installation is completed, ensure all bolts are tightened.

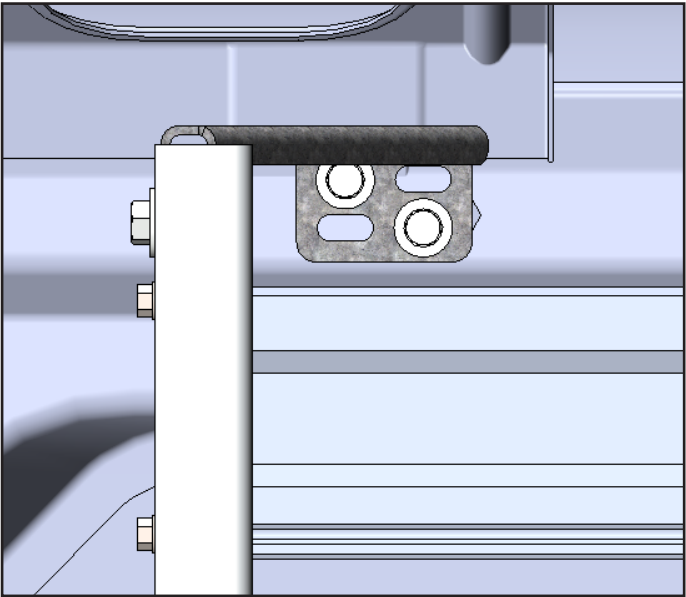
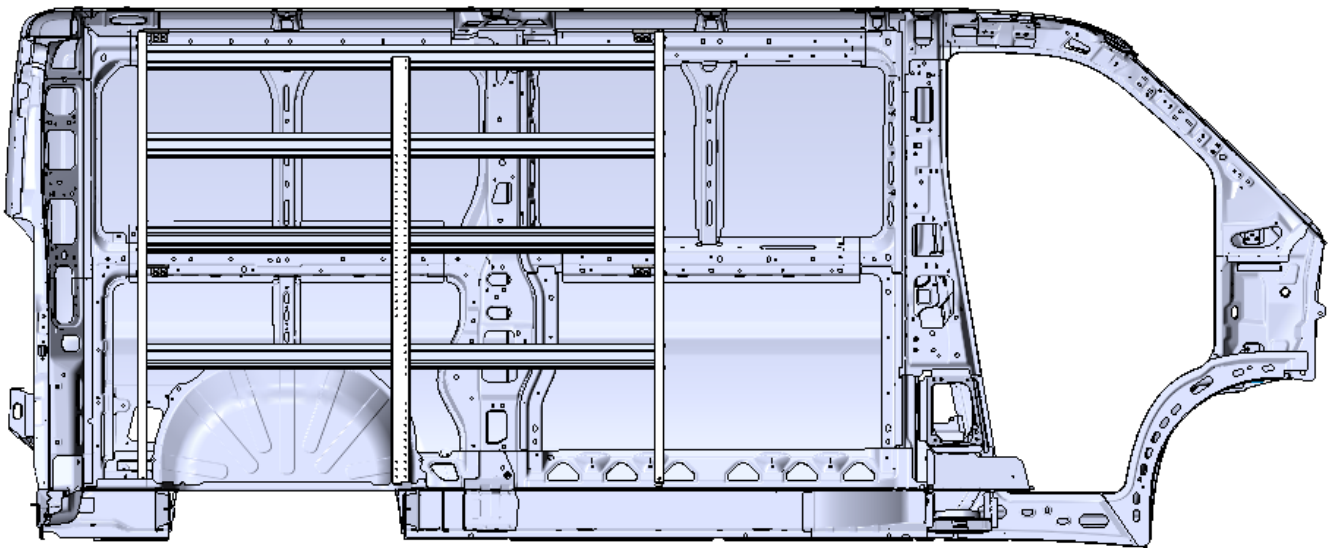





TOOLS

- Cordless Impact
- 1/2" Socket

HARDWARE USED

8x

	#90-212 Hex Bolt 5/16" x 1-1/4"
	#98-122 Lock Washer
	#98-116 Flat Washer
	#94-132 5/16" Plusnut

WITH RANGER WALL KITS

2.5.2 Aligned the wall brackets to the wall mounting track kits, then install the wall brackets to the wall mounting track kits using channel nuts.

NOTE: Tightened the bolts that used to attached the wall bracket to the wall or wall kits 1st before the bolts that used to attached the wall bracket to the end panel.

IMPORTANT: After installation is completed, ensure all bolts are tightened.

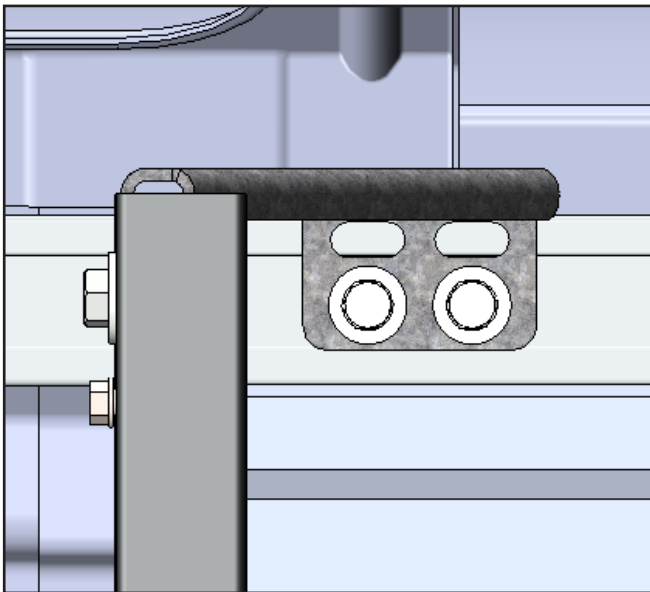
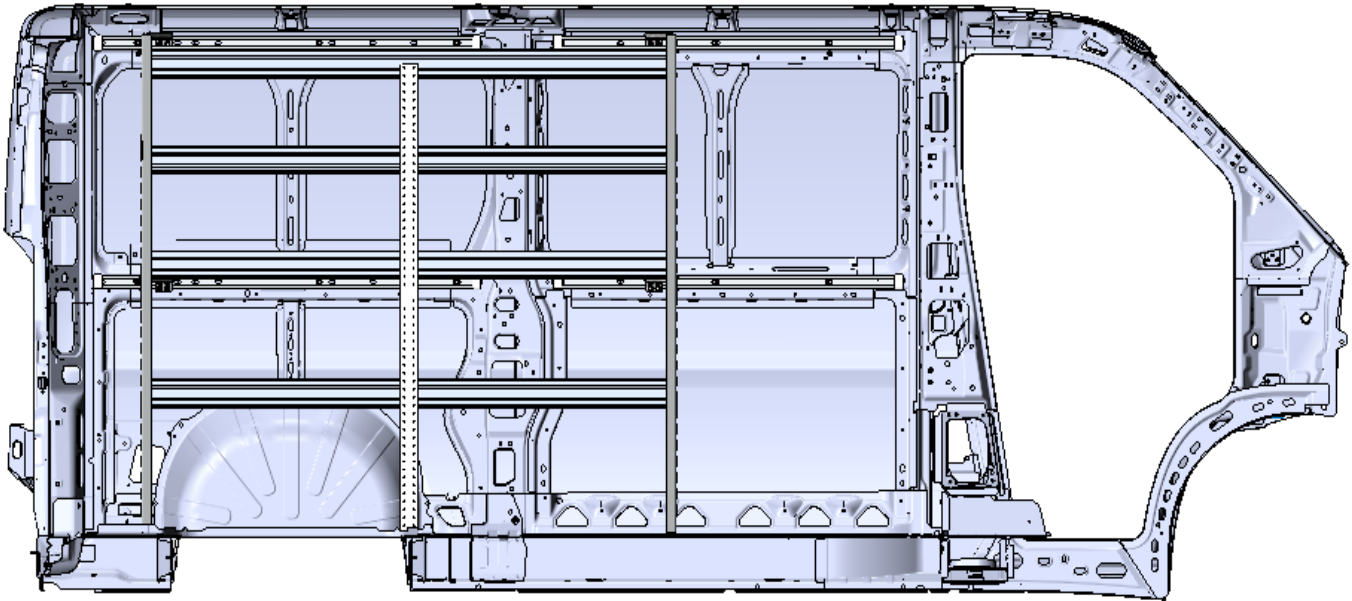

TOOLS

- Cordless Impact
- 1/2" Socket

FASTENERS USED

8x WALL KITS FASTENER KIT

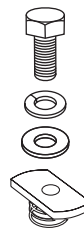

#90-208 Hex Bolt 5/16" x 1"

#98-122 Lock Washer

#98-116 Flat Washer

#94-150 Channel Nut

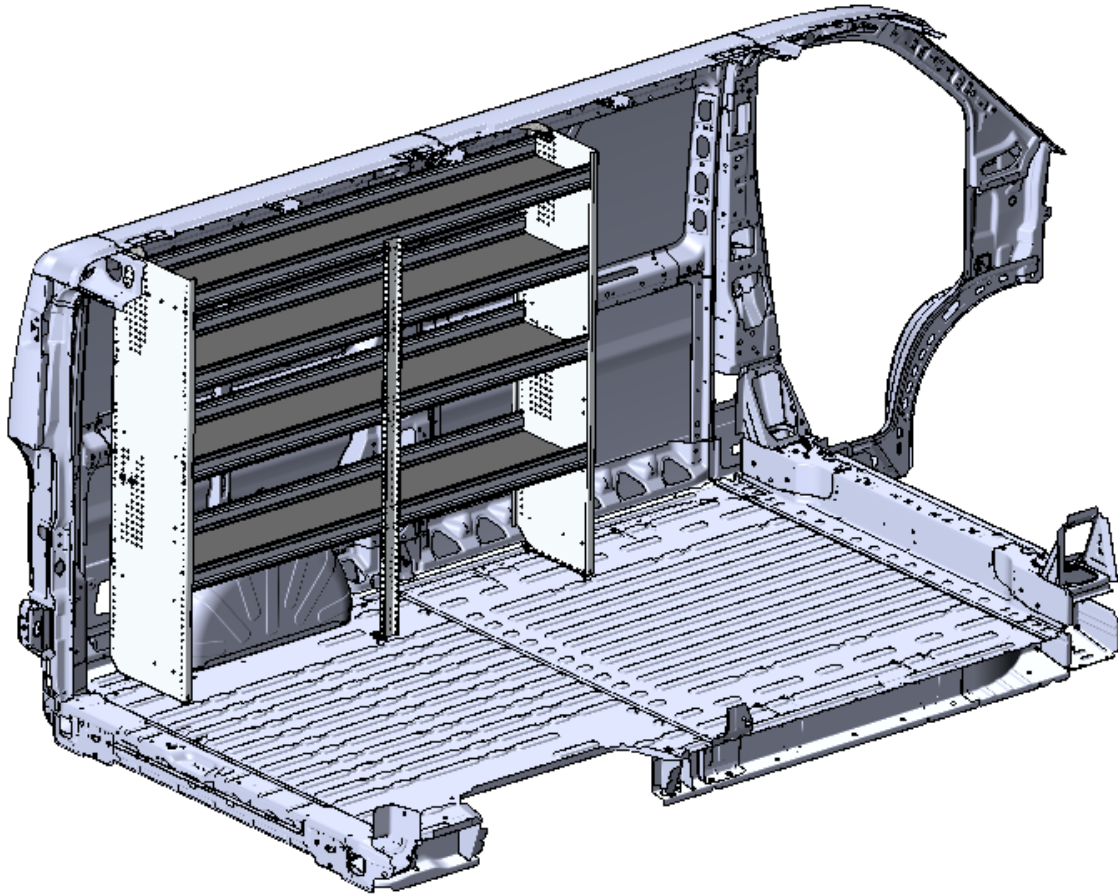

**“You have successfully installed your
N5-RA72-4**

Thank you for doing business with us.”

For any feedback or suggestions you may have, please contact: cs@rangerdesign.com

